

# High Brightness Industrial Display Kit

Model Name : R190-A1HB



## Feature

- High Brightness LED backlight panel for outdoor application.
- LCD controller board provides varied inputs such as VGA, DVI and HDMI.
- LCD controller board support wide variety ranges of TFT LCDs from VGA to SXGA.
- LCD Kits Solution provides matching controller board and all the necessary accessories.

## Panel Specification

Display Size	19"
Resolution	1280x1024
Brightness(cd/m <sup>2</sup> )	1000 (typ.)
Contrast Ratio	1000:1 (typ.)
Display Color	16.7M
Viewing Angle(CR>=10)	-85~85 (H); -80~80 (V)
Active Display Area(mm)	376.32 (H) x 301.06 (V)
Pixel Pitch(mm)	0.294(H)x0.294(V)
Outside dimension	396(H) x 342(V) x 17.8(D)

## Scaler Board Specification

Scaler Board	R7X (Default), R2AH (Optional)
I/Os Support	VGA, DVI
Optional HDMI	Yes (R2AH)
Power Source	12V DC in with power Jack(2.5ψ)

## System block diagram

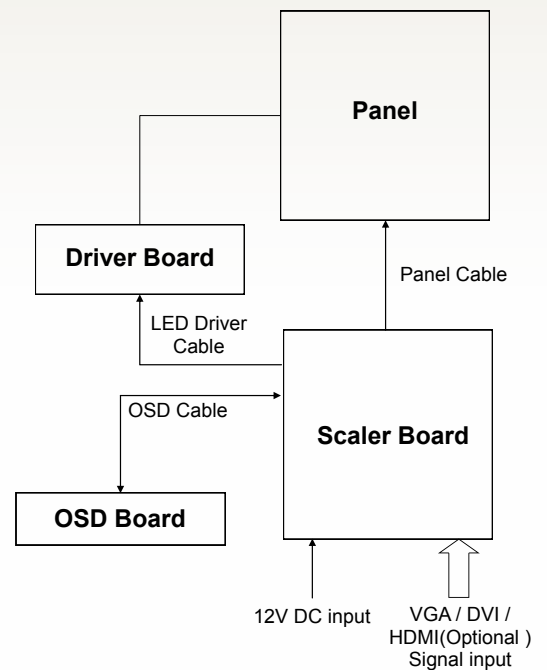

## Components

Panel



Scaler Board



Driver Board



OSD Board



Panel Cable



LED Driver Cable



OSD Cable

