

# R1510

## Hardware Manual

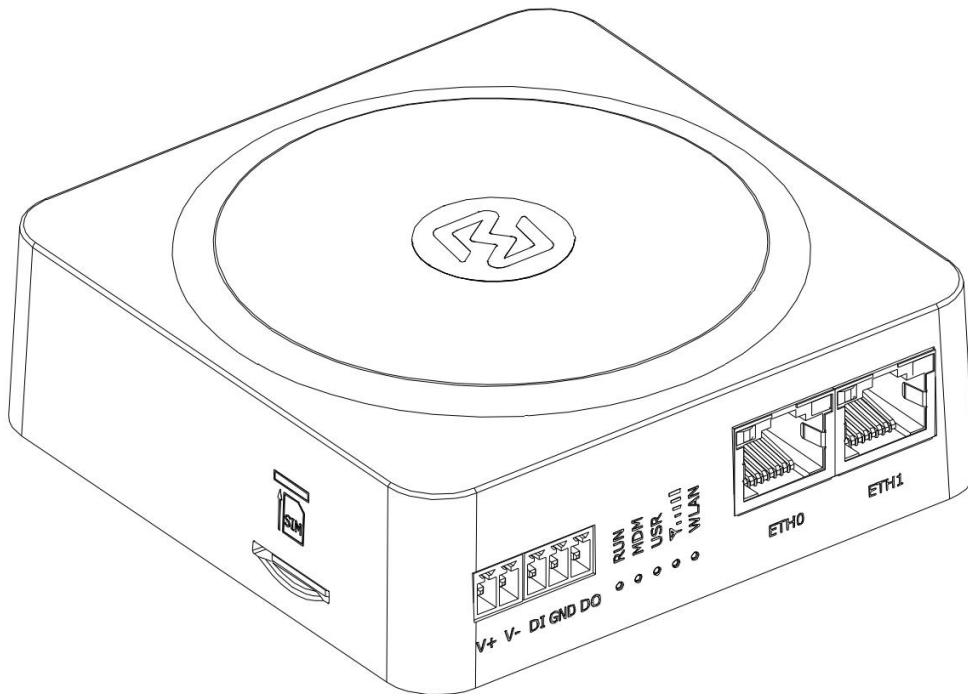

Version: 1.0.0

Date: July 6, 2022

## Regulatory and Type Approval Information

**Table 1:** Toxic or Hazardous Substances or Elements with Defined Concentration Limits

Name of the Part	Hazardous Substances									
	(Pb)	(Hg)	(Cd)	(Cr(VI))	(PBB)	(PBDE)	(DEHP)	(BBP)	(DBP)	(DIBP)
Metal parts	o	o	o	o	-	-	-	-	-	-
Circuit modules	o	o	o	o	o	o	o	o	o	o
Cables and cable assemblies	o	o	o	o	o	o	o	o	o	o
Plastic and polymeric parts	o	o	o	o	o	o	o	o	o	o

o:  
Indicates that this toxic or hazardous substance contained in all of the homogeneous materials for this part is below the limit requirement in RoHS2.0.

X:  
Indicates that this toxic or hazardous substance contained in at least one of the homogeneous materials for this part *might exceed* the limit requirement in RoHS2.0.

-:  
Indicates that it does not contain the toxic or hazardous substance.

## Radio Specifications

RF technologies	2G, 3G, 4G, Wi-Fi
Cellular Frequency*	2G: GSM: B3/B8
	3G: WCDMA: B1/B8
	4G: LTE FDD: B1/B3/B7/B8/B20/B28A
Max RF power	33 dBm±2dB@2G, 24 dBm+1/-3dB@WCDMA, 23 dBm±2 dBm@LTE,

\* *May vary on difference models.*

### Simplified EU Declaration of Conformity

We, Guangzhou Robustel Co., Ltd. are located at 501, Building #2, 63 Yongan Road, Huangpu District, Guangzhou, China, declare that this radio equipment complies with all applicable EU directives. The full text of the EU DoC is available at the following internet address:

[www.robustel.com/certifications/](http://www.robustel.com/certifications/)

### FCC Declaration of Conformity

This device complies with Part 15 of the FCC Rules. Operation is subject to the following two conditions:

- (1) This device may not cause harmful interference.
- (2) This device must accept any interference received, including interference that may cause undesired operation.

### IC Declaration of Conformity

This device contains licence-exempt transmitter(s)/receiver(s) that comply with Innovation, Science and Economic Development Canada's licence-exempt RSS(s). Operation is subject to the following two conditions:

- (1) This device may not cause interference.
- (2) This device must accept any interference, including interference that may cause undesired operation of the device.

L' émetteur/récepteur exempt de licence contenu dans le présent appareil est conforme aux CNR d' Innovation, Sciences et Développement économique Canada applicables aux appareils radio exempts de licence. L' exploitation est autorisée aux deux conditions suivantes :

- (1) L' appareil ne doit pas produire de brouillage;
- (2) L' appareil doit accepter tout brouillage radioélectrique subi, même si le brouillage est susceptible d' en compromettre le fonctionnement.

### Radio Frequency Exposure Statement for IC

This device complies with IC exposure limits set forth for an uncontrolled environment. This device shall be installed and operated with minimum distance 20cm between the radiator & body.

Cet équipement est conforme aux limites d'exposition IC définies pour un environnement non contrôlé. Cet équipement doit être installé et utilisé avec une distance minimale de 20 cm entre le radiateur et la carrosserie.

### Related download link

Find more product documents or tools at:

[www.robustel.com/en/documentations/](http://www.robustel.com/en/documentations/)

### Technical Support

Tel: +86-20-82321505

Email: [support@robustel.com](mailto:support@robustel.com)

Web: [www.robustel.com](http://www.robustel.com)



### Document History

Updates between document versions are cumulative. Therefore, the latest document version contains all updates made to previous versions.





Date	Firmware Version	Document Version	Change Description
July 6, 2022	5.0.0	1.0.0	Initial release.

**Overview**

Robustel R1510 router is a Dual Ethernet port (LAN + WAN) 3G/4G router with advanced software functions at a very competitive price point.

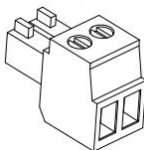
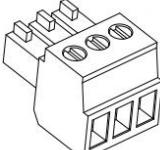
**Package Checklist**

Before commencing installation ensure your package has the following components:

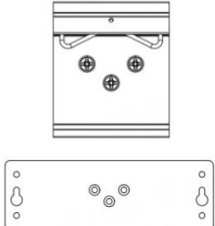
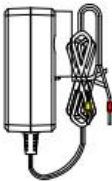
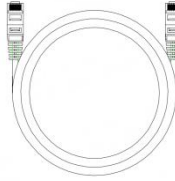
<p>Device</p> 	<p>2PIN Terminal Block</p> 	<p>3PIN Terminal Block</p> 	<p>Cellular Antenna</p> 	<p>Wi-Fi Antenna</p> 
<p>SIM Card Sticking Patch</p> 	<p>Mounting Kit (Optional)</p> 	<p>Power Supply (Optional)</p> 	<p>Ethernet Cable (Optional)</p> 	

**Note:** The accessories could be different on specific order.

**Panel Layout(May vary on difference models)**

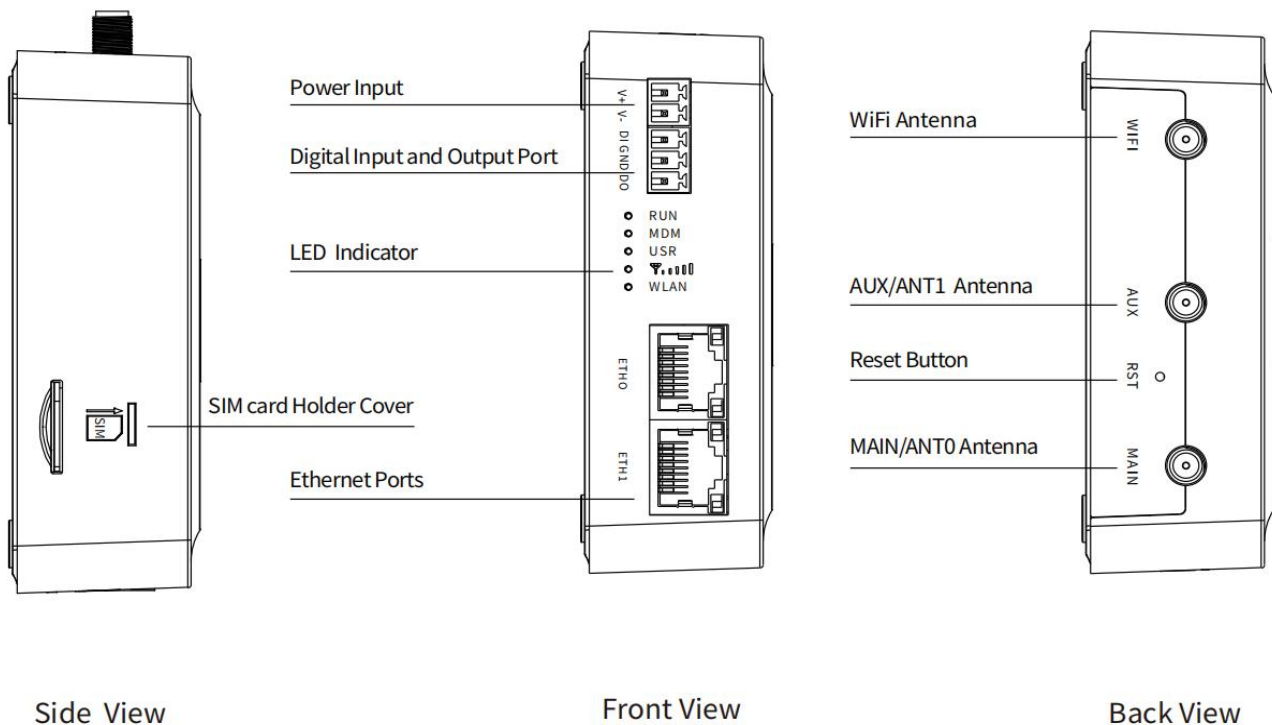

**Interface Descriptions**

**1. Power Supply.** 2PIN 3.5mm pitch terminal block.

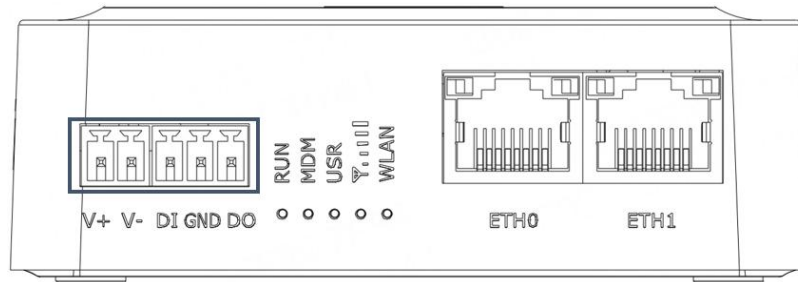

PIN	Power	DI/DO	Description
1	V+	--	Power input Positive, 9-36VDC
2	V-	--	Power input Negative
3	--	DI	Digital input (Maximum absolute voltage: 30V. Maximum absolute current: 20mA)
4	--	GND	Ground
5	--	DO	Digital output (Maximum absolute voltage: 30V. Maximum absolute current: 20mA)

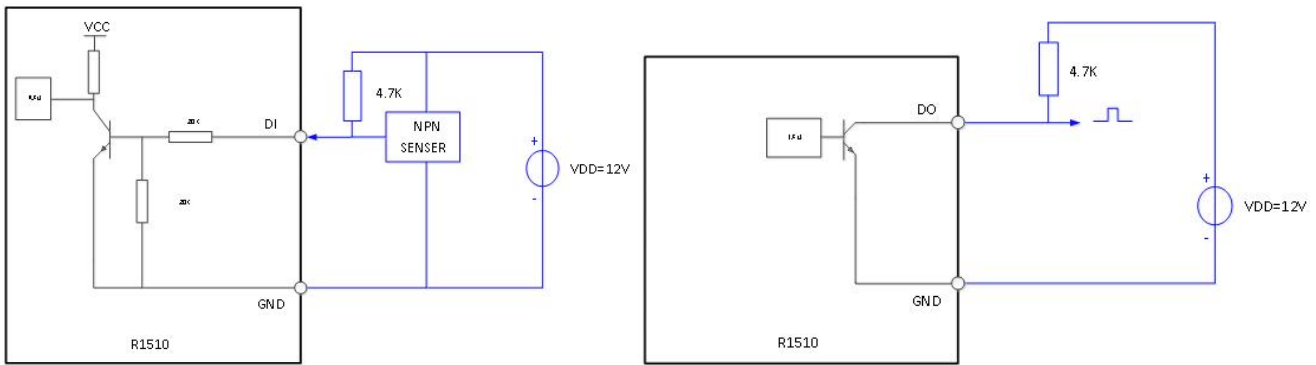

DI&DO Internal Diagram

**2. LED Indicator.**

Name	Color	Status	Description	
RUN	Green	On, solid	Router is powered on (System is initializing)	
		On, blinking	Router starts operating	
		Off	Router is powered off	
MDM	Green	On, solid	Link connection is working	
		On, blinking	Data is sent and received.	
		Off	Link connection is not working	
USR	USR-OpenVPN	Green	On, solid	OpenVPN connection is established
		Off	OpenVPN connection is not established	
	USR-IPsec	Green	On, solid	IPsec connection is established
		Off	IPsec connection is not established	

RSSI	Green	On, solid	Signal Level: Best Signal Level Wireless module: 21-31dB (signal strength)
		On, slow blinking (1s)	Signal Level: Average Signal Level Wireless module: 11-20dB (signal moderate)
		On, fast blinking	Signal Level: Abnormal Signal Level Wireless module: 21-31dB (signal weak)
		Off	No signal
WLAN	Green	On, solid	WLAN is enabled and working properly
	Green	Off	WLAN is disabled or not working properly

Note: You can choose the display type of USB LED. For more details, please refer to **RT123\_SM\_RobustOS Software Manual, Services > Advanced > System > System Settings > User LED Type.**

### 3. Reset Button.

Function	Operation
Reboot	Press and hold the RST button for 2~ 5 seconds under the operating status.
Restore to default configuration	Press and hold the RST button for 5~10 seconds, the RUN LED starts blinking quickly, the router will restore to default configuration.
Restore to factory default settings	Once the operation of restoring default configuration is performed twice within one minute, the router will restore to factory default settings.

Note: The more details please refer to **RT123\_SM\_RobustOS Software Manual, 2.3 Factory Reset.**

**4. Ethernet Ports.** There are two Ethernet ports on R1510, including ETH0 (WAN/LAN), and ETH1. Each has two LED indicators. The green one is a link indicator but the yellow one doesn't mean anything. For details about status, see the table below.

Ethernet LED Indicator	Status	Description
Link indicator (Green)	On, solid	Connection is established
	On, blinking	Data is being transferred
	Off	Connection is not established

## Hardware Installation

1. **SIM Card Installation.** Insert the SIM cards into the device, then stick the sticker.

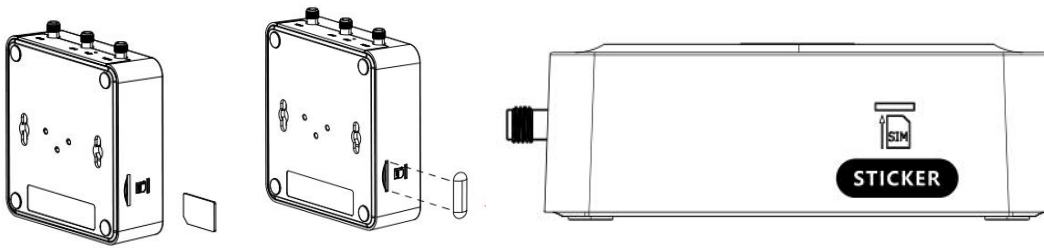

2. **Antenna Installation.** Rotate the antenna into the antenna connector accordingly.



3. **Terminal Block Installation.** Insert the 2PIN、3PIN terminal blocks into the interfaces connector.

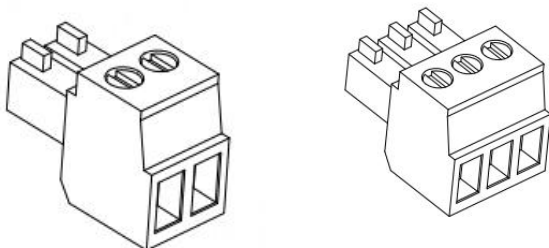

4. **Mounting Kit installation.**

- ① Wall mounting

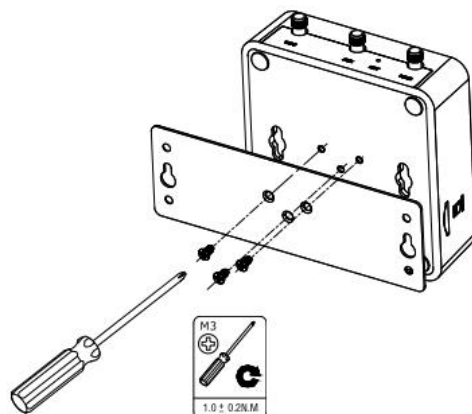



② DIN rail mounting

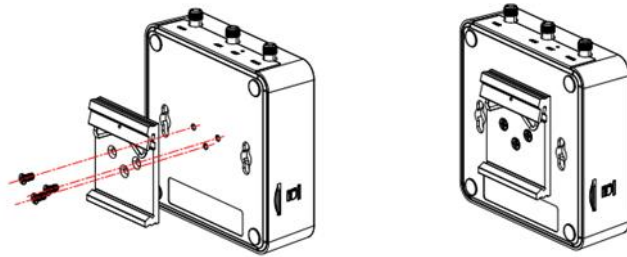

5. Connect the Router to a Computer



6. **Power Supply installation.** There are two cables associated with the power adapter. Following to the color of the head, connect the cable marked red to the positive pole through a terminal block, and connect the yellow one to the negative in the same way.

Note: The range of power voltage is 9 to 36V DC.

**CONNECTING THE POWER CABLE**

COLOR	POLARITY
RED	+
YELLOW	-

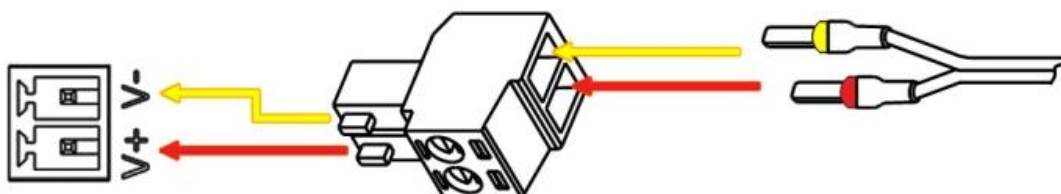

**Login to the Device**

1. Connect the router's Ethernet port to a PC with a standard Ethernet cable.
2. Before logging in, manually configure the PC with a static IP address on the same subnet as the gateway address, click and configure "Use the following IP address".

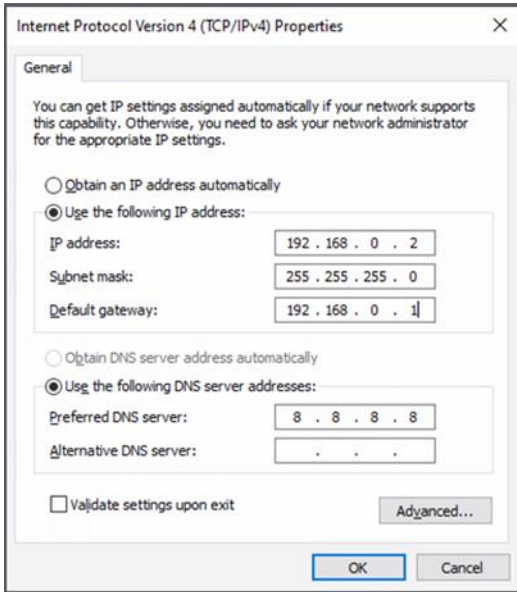

3. To enter the gateway's web interface, type <http://192.168.0.1> into the URL field of your Internet browser.

4. Use login information shown in the product label when prompted for authentication.

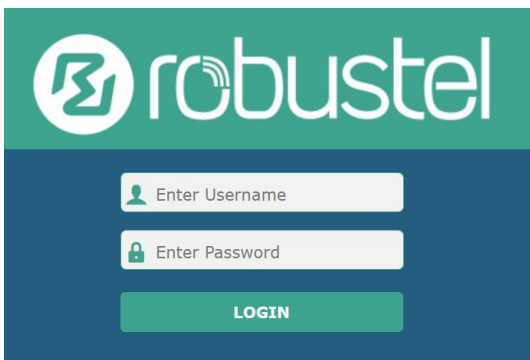

5. After logging in, the home page of the web interface is displayed, then you can view system information and perform configuration on the device.

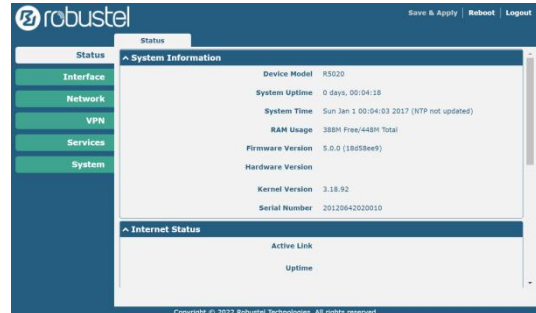

6. The automatic APN selection is ON by default, if need to specify your own APN, please go to the menu **Interface->Link Manager->Link Setting->WWAN Settings** to finish the specific setting.

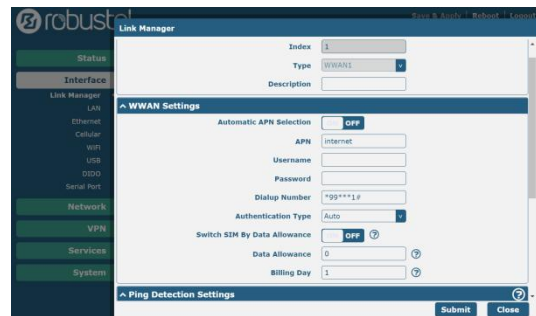

7. The more configuration details please refer to **RT123\_SM\_RobustOS Software Manual**.  
(END)