

eBOX-NNZ-C2 (Black edition) eBOX-NNZ-B-C2(Black edition)

- Fanless Industrial BOX PC
- Low power consumption
- and high performance



Feature

- Intel® Core™6/7/8/ or 10/11th generation i7/i5/i3, Pentium/Celeron LGA1151 /LGA1200type CPU. (MAX CPU TDP 35W)
- 3 x Intel GbE LAN
- 4 x USB3.0, 2 x USB2.0, 6 x RS232/RS485
- 1 x mSATA,1 x M.2 NVME SSD (Specifications 2280)
- 8 x DI photoelectric isolation wet contact, isolation class 2500Vrms
- 8 x DO, OC gate output, isolation class 2000Vrms
- DC12-24VPower supply with overcurrent, overvoltage and polarity inverse protection
- Wide operating temperature -20 ~ 60°C supported



Specifications



Model Name		eBOX-NNZ-C2	eBOX-NNZ-B-C2
Processor	CPU	Intel® Core™6/7/8/9th generation i7/i5/i3, Pentium/Celeron LGA1151 type CPU. (MAX CPU TDP 35W)	Intel® Core™10/11th generation i7/i5/i3, Pentium/Celeron LGA1200 type CPU. (MAX CPU TDP 35W)
Memory	DIMM	2*DDR4L-2400MHz, MAX 32GB	
Storage	SSD	1 x mSATA,1 x M.2 NVME SSD (Specifications 2280)	
I/O	USB	4x USB3.0, 2x USB2.0	
	COM	4 x COM1-4, selectable to support RS232 or RS485 mode by the switch, RS485 support auto flow control Optional 2 * CAN buses or 2 * RS232/485 (COM5-6)	
Ethernet	LAN	3 x 10/100/1000Mbps Ethernet	
Display	HDMI	4096 x 2160@30Hz	
Other	Watch Dog	0~255 level programmable	
Power	Voltage Input	DC12-24V ±10%, overcurrent, overvoltage and polarity inverse protection	
	Power Consumption	Typical:35W	
Chassis	Structure	Aluminum-magnesium alloy box, Fanless, Wall-mounted	
	Dimensions	(L)256mm x (W)173mm x (H)59.5mm	
	Net Weight	2Kg	
Reliability	Work Temperature	-20°C ~ 60°C (-4°F~140°F) with air flow (mSATA), 5~95% (Non-condensing)	
	Storage Temperature	-40°C ~ 80°C (-40°F ~ 176°F) with air flow (msATA), 5~95% (Non-condensing)	
	Operating Vibration	5~500Hz, 1.5Grms@with SSD, Follow IEC60068-2-64	
	Operating Shock	10G peak acceleration(11ms duration) with SSD, Follow IEC60068-2-27	
	EMC	CE/FCC Class B	
OS	Microsoft Windows	Windows 7, Windows 10	
	Linux	Ubuntu	

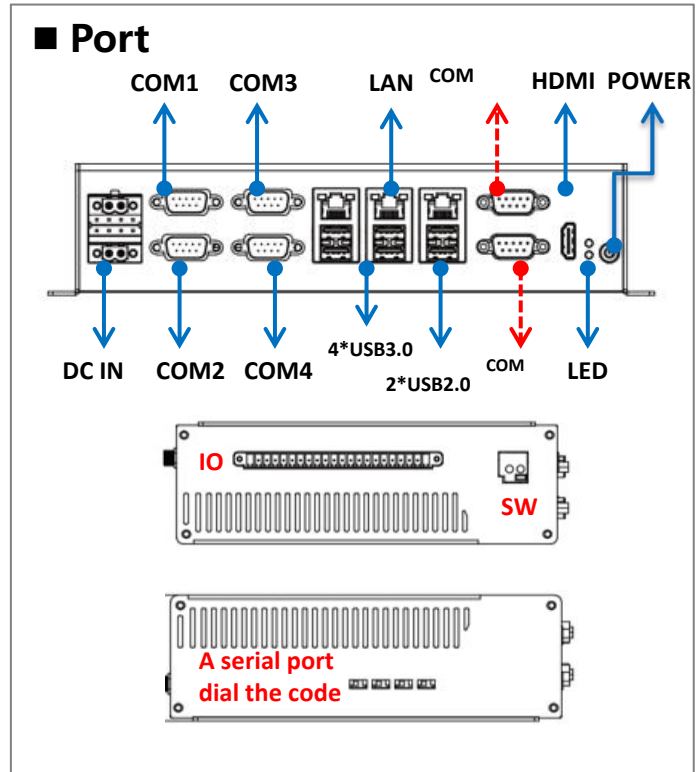
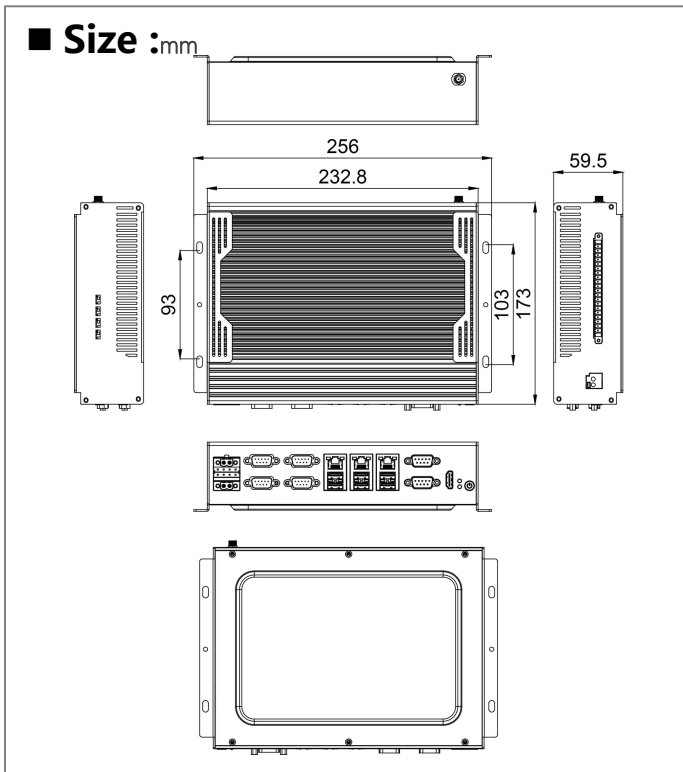

■ **Port**

Pin No.	Signal	Pin No.	Signal
1	PCOM	2	DOGND
3	D00	4	D01
5	D02	6	D03
7	D04	8	D05
9	D06	10	D07
11	DI-24V	12	DIGND
13	DICOM	14	DIO
15	DI1	16	DI1
17	DI3	18	DI3
19	DI5	20	DI5
21	DI7	22	GND

Ordering Information

P/N	Model Name	Specifications
00-06165981	eBOX-NNZ-C2	Net products: H110 chipset /4*(RS232/485)/3LAN/4USB3.0/2USB2.0/DC12-24V input
00-06165979	eBOX-NNZ-B-C2	Net products: L520 chipset /4*(RS232/485)/3LAN/4USB3.0/2USB2.0/DC12-24V input

Options

Accessories	Specifications
DDR4 memory	4GB,8GB,16GB
mSATA	128G,256G,512G... ..
M.2 SSD	512GB, 1TB... ..
Serial card	mini PCIE: SGW-ME352A_V16
CAN	mini PCIE: CAN_F81604

Note: If the system provides some optional parts, additional certification of system compatibility may be required in some regions/countries, please contact NODKA for system compatibility