



KEY TECHNOLOGY (CHINA) LIMITED

深圳市键特电子有限公司



Head Office: B703, Building 1, Tianan Cyber Park, Huang Ge North Road, Longcheng Subdistrict, Long Gang District, ShenZhen, Guang Dong, P.R. China

Factory ADD.: Floor 7, Building S8, Fenggang Tianan Cyber Park, No. 208 Fenggang Section, Dongshen Road, Fenggang Town, DongGuan, Guang Dong, P.R. China

Tel: +86 755 89239859, 89230460, 85232807

Fax: +86 755 89312576

E-mail: info@key-tek.cn, sales01@key-tek.cn

Website: www.key-tek.cn, www.rugged-key.com

Model NO: K-TEK-A95TP-DWP

Description: IP65 dynamic Sealed and Ruggedized Tough Touchpad for fast and accurate cursor position, with 2 raised IP65 dynamic sealed stainless steel mouse keys under touchpad, the electronics controller module shielded and protected with stainless steel housing, stainless steel top plate with threaded bolts for top panel mounting solution. One complete silicone rubber along the rear stainless steel plate for easy mounting & sealing tightly with cabinet. Which is good for outdoor application with direct rain and very harsh environments with humidity, much dynamic water, oil, dirt, salt mist etc, no rust risk and anti-salt spray corrosion.

Dimension: 95.0mm x 95.0mm (front panel)

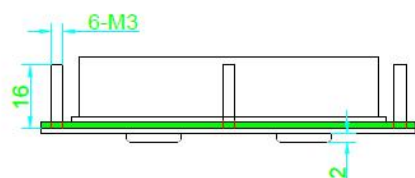
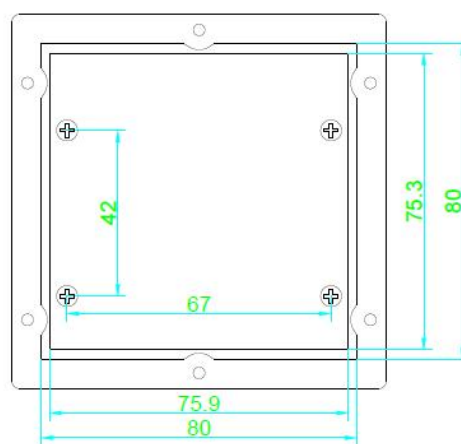
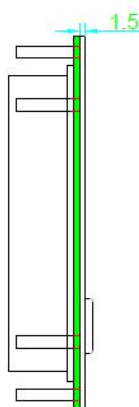
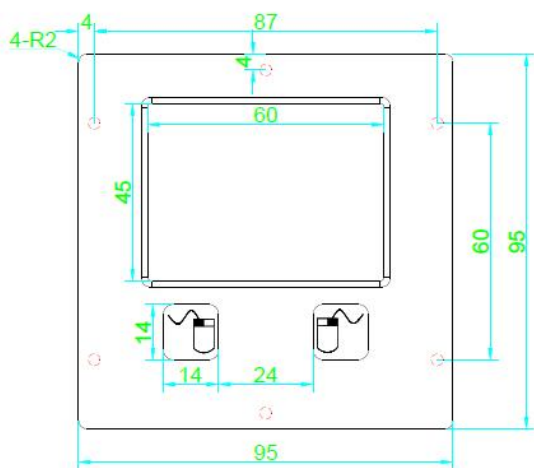



KEY TECHNOLOGY (CHINA) LIMITED

深圳市键特电子有限公司



Head Office: B703, Building 1, Tianan Cyber Park, Huang Ge North Road, Longcheng Subdistrict, Long Gang District, ShenZhen, Guang Dong, P.R. China

Factory ADD.: Floor 7, Building S8, Fenggang Tianan Cyber Park, No. 208 Fenggang Section, Dongshen Road, Fenggang Town, DongGuan, Guang Dong, P.R. China

Tel: +86 755 89239859, 89230460, 85232807

Fax: +86 755 89312576

E-mail: info@key-tek.cn, sales01@key-tek.cn

Website: www.key-tek.cn, www.rugged-key.com

TECHNICAL SPECIFICATION

ITEM		SPECIFICATION
Mechanical	Front Plate	Quality brushed stainless steel
	Touchpad thickness	1.5 mm PCB thickness inclusive of mylar layer
	Validated touch width	45.0mm (max)
	Validated touch length	60.0mm (max)
	Mounting Solution	Front panel mounted with threaded bolts
	Back Metal Cover	Rear side integrated electronics protected by a metal cover
	Touchpad lifespan	> 5 years
	Dimensions	Touchpad: 60.0mm x 45.0mm; Front Mounting Panel: 95.0mm x 95.0mm (front panel), Rear Mounting Panel: 80.0mm x 80.0mm
Interface	PS2 and USB both available	
Electrical	Power supply	DC +5V ± 5%
	Work current	17 mA (normal)
	X/Y position sensing resolution:	1000 points/inch (40 points/mm)
	X/Y position reporting:	Relative
	Tracking speed:	Maximum 1,016 m/sec
	Protection level:	IP65 dynamic (front panel)
	Static Release:	15 KV (front panel)
	EMC Standard:	EN 55032:2015, EN 55035:2017
Environmental	Operating temperature:	-20°C to +65°C
	Storage temperature:	- 30°C to + 75°C
	Operating RH:	10%-95%
	Atmospheric pressure:	60-106Kpa
Reliability	MTBF	>20000h
	MTTR	< 30min
	Key switch lifespan	>5 million actuations
OS	All Windows, Linux, Unix, Mac OSX, Vxworks, Android, (U-cos--To be confirmed)	



KEY TECHNOLOGY (CHINA) LIMITED

深圳市键特电子有限公司



Head Office: B703, Building 1, Tianan Cyber Park, Huang Ge North Road, Longcheng Subdistrict, Long Gang District, ShenZhen, Guang Dong, P.R. China

Factory ADD.: Floor 7, Building S8, Fenggang Tianan Cyber Park, No. 208 Fenggang Section, Dongshen Road, Fenggang Town, DongGuan, Guang Dong, P.R. China

Tel: +86 755 89239859, 89230460, 85232807

Fax: +86 755 89312576

E-mail: info@key-tek.cn, sales01@key-tek.cn

Website: www.key-tek.cn, www.rugged-key.com

Packing Details	Each unit to a suitable brown inner box, suitable brown inner boxes to a standard export carton.
Application	Industrial, coal and mine, medical, bank kiosk and self service terminal, public access, explosion-proof automation, oil and gas etc.