

# PM-3133 Quick Start

## 1. Shipping Package

This shipping package contains the following items

1 x PM-3133 module



1 x Quick Start



Screw Driver x 1



CD x 1



Cable ties x 3



## 2. PM-3133 introduction

ICP DAS offers PM-3133 family in a full range of Single-phase and Three-phase smart power meters for power monitoring. The products offer a rich feature set combined with easy-to-integrate communications.

With its high accuracy ( $<0.5\%$ ,  $PF=1$ ), the PM-3133 series products can be applied both on low voltage primary side and/or medium/high voltage secondary side and enable the users to obtain in real time the reliable and accurate energy consumption readings from the monitored equipments while in operation. These compact size and cost effective Power Meters are equipped with revolutionary wired clip-on CT (various types support input current up to 200A) and standard Modbus communication RS-485 protocol for easy deployment. It works with input voltages ranging 10V ~ 500V, supporting a wide range of applications.

### 2.1. Caution & Warning



The meter contains hazardous voltages, and should never be disassembled. Failing to follow this practice will result in serious injury or death. Any work on or near energized meters, meter sockets, or other metering equipment could induce a danger of electrical shock. It is strongly recommended that all work should be performed only by qualified industrial electricians and metering specialist. ICP DAS assumes no responsibility if your electrical installer does not follow the appropriate national and local electrical codes.

ICP DAS assumes no liability for any damage resulting from the use of this product. ICP DAS reserves the right to change this manual at any time without notice. The information furnished by ICP DAS is believed to be accurate and reliable. However, no responsibility is assumed by ICP DAS for its use, not for any infringements of patents or other rights of third parties resulting from its use.

### 2.2. Product Warranty & Customer Support

ICP DAS warrants all products free from defects in material and workmanship for a period of one year from the date of shipping. During the warranty period, we will, at our position, either repair or replace any product that proves to be defective. To report any defect, please contact : **+886-3- 597-3366** or [service@icpdas.com](mailto:service@icpdas.com).

#### 2.2.1. Limitation of Warranty

This warranty does not apply to defects resulting from unauthorized modification, misuse, or use for reason other than electrical power monitoring. The supplied meter is not a user-serviceable product.

## 3. Installation

Please use the soft dry clothes to clean the instrument.

Please do not use any chemical or detergent or volatile solvents to clean the instrument, in order to avoid any possibility of the cover damage.

### 3.1.

- Dimension: 127mm (length) × 33mm (wide) × 105mm (high)
- Products come with external split type clip-on CT's. Disconnect the CT's or use other CT's is highly prohibited.
- Please read this operation manual carefully before using.
- Please re-confirm the measure position.
- Reconfirm the RST (ABC) phase sequence of the power system.
- PM-3133 series can be installed as rail mounting mode or embedded, no need to drill a hole or screw to fix it (rail mounting width can up to the length of 35 mm).
- Meter auxiliary power for PM-3133 series is DC +12V ~+48V.

### 3.2. Voltage Input

1. PM-3133 series: Input Voltage up to 500V.  
For any higher Input Voltage large than 500V, please add the PT (power transformer), and Change PT RATIO setup.
2. Confirm the RST (ABC) phase sequence.

### 3.3. Current Input

1. The external CT's are fragile, please handle with care.
2. The current input of PM-3133 series is in mA range. Only the ex-factory attached CT's can be used. The other CT's, for example, from panel will damage the instrument due to its large current (around 5A).
3. The current input of PM-3133-xxxP series is in mV range. Only the ex-factory attached CT's can be used. The other CT's, for example, from panel will damage the instrument due to its large current (around 5A or mA).
4. When more than one smart meter (PM-3133 series) are installed, please do not disconnect the CT with its original meter and mix use with each other. Since each set of smart meter (PM-3133 series) and its attached split type clip-on CT are calibrated set by set. The mix use may cause wrong measurements.
5. To install CT's correctly, please ensure the CT lines sequences is right before clip the CT's onto the power cable of the monitoring equipment. (Detail will be found in next section)



6. **When measuring the current, the secondary circuit of a CT should never be opened when a load is passing through its primary. Make sure you always open the CT clip to detach the CT before removing the terminal lines. Otherwise, it will cause severe injury.**

7. Please handle with extra care, especially when the operation space of CT's is limited.
8. The current direction must follow K-L marked on CT's.
9. Please select the right size CT's for different size of monitoring equipment cables:  
power cable diameter <math>\Phi 10</math> use 60A CT ,  $\Phi 10 \sim \Phi 16</math> use 100A CT ,  $\Phi 16 \sim \Phi 24</math> use 200A CT  
 ,  $\Phi 24 \sim \Phi 36</math> use 300A or 400A CT .$$$
10. The maximum current value cannot exceed the CT rating.

### 3.4. Connection

- PM-3133

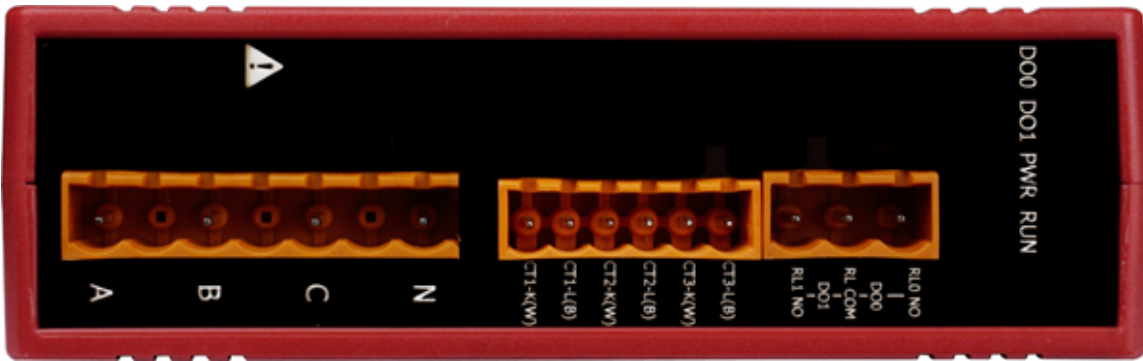

Please firstly check the current input terminal, and then in white black, white black, white black wire sequences (CT1-K,CT1-L,CT2-K,CT2-L,CT3-K,CT3-L). Then connect the CT's, and close the CT clip. Make sure the arrow direction sign on CT's follows current flow direction (K→L)

**Note: it must be in the same direction.**

Connect the voltage input terminal N C B A. for PM-3133, in the three phase order as follows on N C B A.

**Attention please!! For 3P3W-2CT, connect in N C A phase sequence, do not connect phase B (Check the diagram).**

### 3.5. CT's installation steps

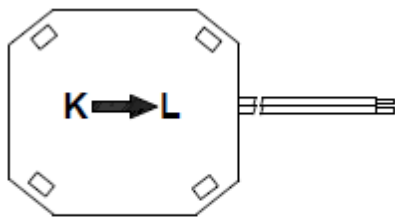

Bottom view

- At the bottom of the CT, there is a "K→L" mark.



- Open the CT clip.



- Make sure the power current direction follow the "K→L" mark on the CT and then close the CT clip.



- Installation steps finished.

### 3.6. Wiring

- 1P2W-1CT(PM-3133)

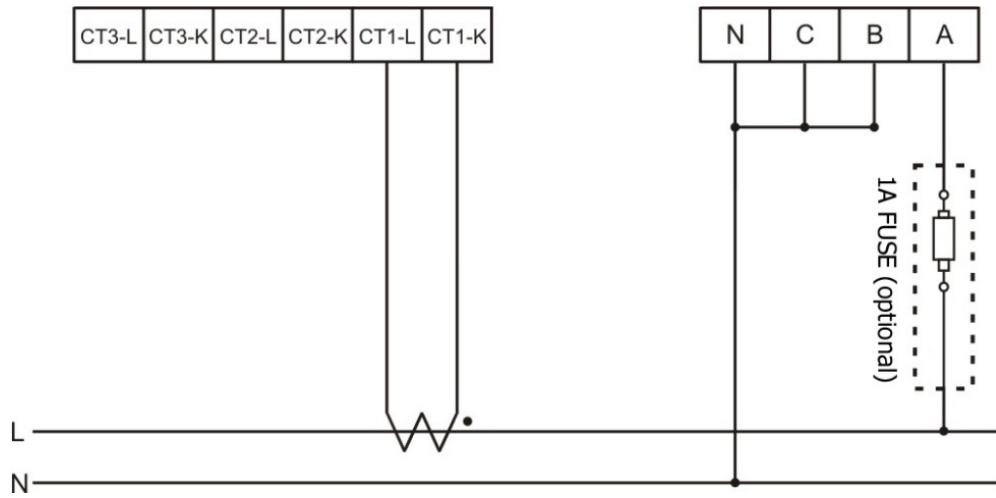

- 1P3W-2CT(PM-3133)

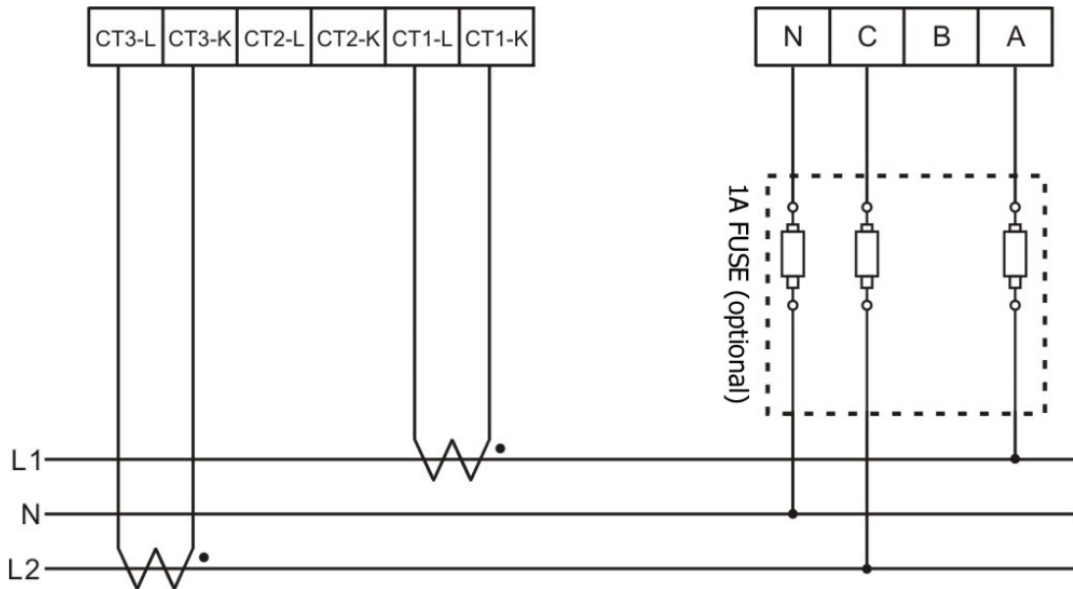

- 3P3W-2CT(PM-3133)

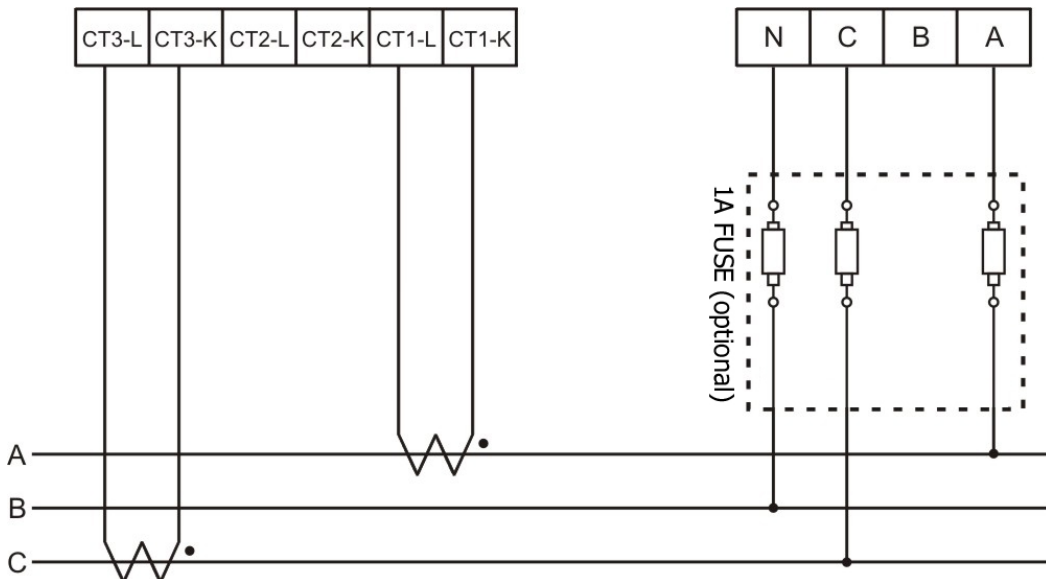

- 3P3W-3CT(PM-3133)

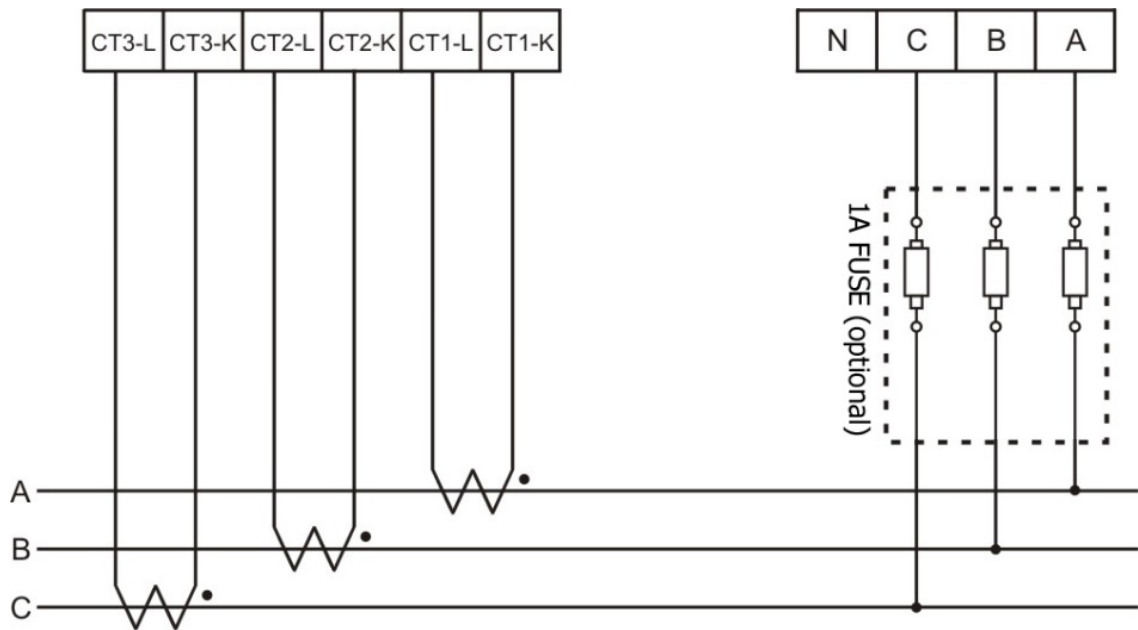

- 3P4W-3CT(PM-3133)

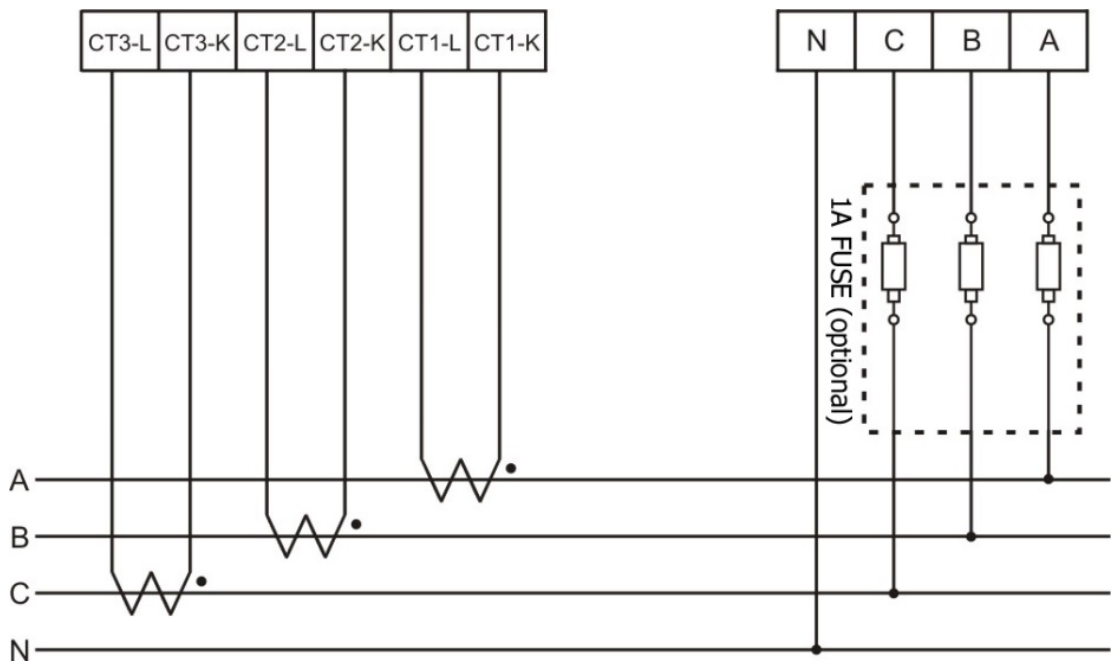

#### 4. Relay Output & LED Indicator

- Relay Output

Relay type	Power Relay, Form A (SPST N.O.)
Operating Voltage Range	250 VAC/30 VDC
Max. Load Current	5 A at 25 °C

- LED Indicator

The PM-3133 has 4 LED to indicate the unit power status, communication, and power data calculation.

- RUN: Green, light up after communication ready. LED will flash when the unit is processing communication.
- PWR: Red, Power on LED always on.
- DO0: Green. LED DO0 will light up, when DO0 is "ON".
- DO1: Green. LED DO1 will light up, when DO1 is "ON".

## 5. Communication

### 5.1. RS-485 & CAN setting

- Default setting for RS-485: **19200, n, 8, 1**, for CAN: **125K bps**
- DIP switch (SW1-SW6) is used for Modbus address(or CANopen Node ID) setting, default is 1, i.e. all OFF

**For example:** Modbus address(or CANopen Node ID) is 10 · find the table of DIP switch 1-6 is **ON, OFF, OFF, ON, OFF, OFF**

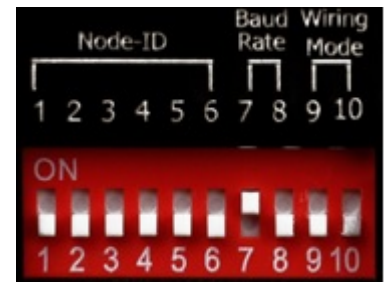

- SW1 – SW6 setting

Setting Modbus-RTU address for communication (1-64)

Modbus Address	SW 1	SW 2	SW 3	SW 4	SW 5	SW 6
1	OFF	OFF	OFF	OFF	OFF	OFF
2	<b>ON</b>	OFF	OFF	OFF	OFF	OFF
3	OFF	<b>ON</b>	OFF	OFF	OFF	OFF
4	<b>ON</b>	<b>ON</b>	OFF	OFF	OFF	OFF
5	OFF	OFF	<b>ON</b>	OFF	OFF	OFF
6	<b>ON</b>	OFF	<b>ON</b>	OFF	OFF	OFF
7	OFF	<b>ON</b>	<b>ON</b>	OFF	OFF	OFF
8	<b>ON</b>	<b>ON</b>	<b>ON</b>	OFF	OFF	OFF
9	OFF	OFF	OFF	<b>ON</b>	OFF	OFF
10	<b>ON</b>	OFF	OFF	<b>ON</b>	OFF	OFF
11	OFF	<b>ON</b>	OFF	<b>ON</b>	OFF	OFF
12	<b>ON</b>	<b>ON</b>	OFF	<b>ON</b>	OFF	OFF
13	OFF	OFF	<b>ON</b>	<b>ON</b>	OFF	OFF
14	<b>ON</b>	OFF	<b>ON</b>	<b>ON</b>	OFF	OFF
15	OFF	<b>ON</b>	<b>ON</b>	<b>ON</b>	OFF	OFF
16	<b>ON</b>	<b>ON</b>	<b>ON</b>	<b>ON</b>	OFF	OFF
17	OFF	OFF	OFF	OFF	<b>ON</b>	OFF
18	<b>ON</b>	OFF	OFF	OFF	<b>ON</b>	OFF
19	OFF	<b>ON</b>	OFF	OFF	<b>ON</b>	OFF
20	<b>ON</b>	<b>ON</b>	OFF	OFF	<b>ON</b>	OFF
21	OFF	OFF	<b>ON</b>	OFF	<b>ON</b>	OFF
22	<b>ON</b>	OFF	<b>ON</b>	OFF	<b>ON</b>	OFF
23	OFF	<b>ON</b>	<b>ON</b>	OFF	<b>ON</b>	OFF
24	<b>ON</b>	<b>ON</b>	<b>ON</b>	OFF	<b>ON</b>	OFF
25	OFF	OFF	OFF	<b>ON</b>	<b>ON</b>	OFF
26	<b>ON</b>	OFF	OFF	<b>ON</b>	<b>ON</b>	OFF
27	OFF	<b>ON</b>	OFF	<b>ON</b>	<b>ON</b>	OFF
28	<b>ON</b>	<b>ON</b>	OFF	<b>ON</b>	<b>ON</b>	OFF
29	OFF	OFF	<b>ON</b>	<b>ON</b>	<b>ON</b>	OFF
30	<b>ON</b>	OFF	<b>ON</b>	<b>ON</b>	<b>ON</b>	OFF
31	OFF	<b>ON</b>	<b>ON</b>	<b>ON</b>	<b>ON</b>	OFF
32	<b>ON</b>	<b>ON</b>	<b>ON</b>	<b>ON</b>	<b>ON</b>	OFF
33	OFF	OFF	OFF	OFF	OFF	<b>ON</b>
34	<b>ON</b>	OFF	OFF	OFF	OFF	<b>ON</b>
35	OFF	<b>ON</b>	OFF	OFF	OFF	<b>ON</b>
36	<b>ON</b>	<b>ON</b>	OFF	OFF	OFF	<b>ON</b>
37	OFF	OFF	<b>ON</b>	OFF	OFF	<b>ON</b>
38	<b>ON</b>	OFF	<b>ON</b>	OFF	OFF	<b>ON</b>
39	OFF	<b>ON</b>	<b>ON</b>	OFF	OFF	<b>ON</b>
40	<b>ON</b>	<b>ON</b>	<b>ON</b>	OFF	OFF	<b>ON</b>
41	OFF	OFF	OFF	<b>ON</b>	OFF	<b>ON</b>

42	ON	OFF	OFF	ON	OFF	ON
43	OFF	ON	OFF	ON	OFF	ON
44	ON	ON	OFF	ON	OFF	ON
45	OFF	OFF	ON	ON	OFF	ON
46	ON	OFF	ON	ON	OFF	ON
47	OFF	ON	ON	ON	OFF	ON
48	ON	ON	ON	ON	OFF	ON
49	OFF	OFF	OFF	OFF	ON	ON
50	ON	OFF	OFF	OFF	ON	ON
51	OFF	ON	OFF	OFF	ON	ON
52	ON	ON	OFF	OFF	ON	ON
53	OFF	OFF	ON	OFF	ON	ON
54	ON	OFF	ON	OFF	ON	ON
55	OFF	ON	ON	OFF	ON	ON
56	ON	ON	ON	OFF	ON	ON
57	OFF	OFF	OFF	ON	ON	ON
58	ON	OFF	OFF	ON	ON	ON
59	OFF	ON	OFF	ON	ON	ON
60	ON	ON	OFF	ON	ON	ON
61	OFF	OFF	ON	ON	ON	ON
62	ON	OFF	ON	ON	ON	ON
63	OFF	ON	ON	ON	ON	ON
64	ON	ON	ON	ON	ON	ON

- SW7 – SW8 For Baud Rate Setting

RS-485	CAN	SW 7	SW8
9600 bps	125k(Default) bps	OFF	OFF
19200 (Default) bps	250k bps	ON	OFF
38400 bps	500k bps	OFF	ON
115200 bps	1M bps	ON	ON

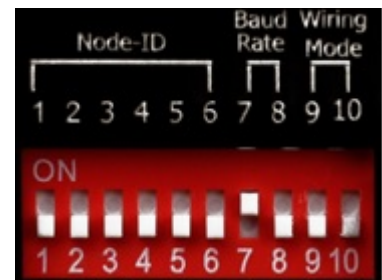

PM-3133 : Select the different wiring mode

(Please select the Software setting, if 1P2W-1CT or 1P3W-2CT is used)

Models	PM-3133		PM-3133-MTCP	
	SW 9	SW 10	SW 1	SW 2
Software setting	OFF	OFF	OFF	OFF
3P3W-2CT	ON	OFF	ON	OFF
3P3W-3CT	OFF	ON	OFF	ON
3P4W-3CT	ON	ON	ON	ON

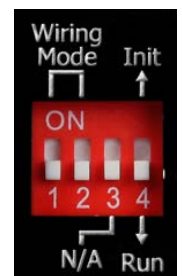

## 5.2. Add the Bias Resistor on RS-485 Network for stable signal

The RS-485 master is required to provide the bias for PM-31xx series. Otherwise, the tM-SG4 or SG-785 should be added to provide the bias. All ICP DAS controllers and converters provide the bias.

## 5.3. Ethernet setting

- Ethernet default settings:

IP Address	192.168.255.1
Subnet mask	255.255.0.0
Gateway	192.168.0.1
Port	502

## 5.4. Specifications

Model	PM-3133	PM-3133-MTCP	PM-3133-CPS	
<b>AC Power Measurement</b>				
Wiring	1P2W-1CT, 1P3W-2CT, 3P3W-2CT, 3P3W-3CT and 3P4W-3CT			
Input Voltage	10 ~ 500 V (CAT III); Input Frequency: 50/60 Hz			
Input Current	CT $\Phi$ 10 mm (60 A); CT $\Phi$ 16 mm (100 A); CT $\Phi$ 24 mm (200 A); CT $\Phi$ 36 mm (300 A); CT $\Phi$ 36 mm (400 A)			
Input Frequency	50/60 Hz			
W Accuracy	Better than 0.5% (PF=1)			
Starting Current	>0.03A ( 60A ), >0.05A (100A ), >0.09A( 200A )			
Power Parameter Measurement	True RMS voltage (Vrms), True RMS current (Irms), Active Power (kW), Active Energy (kWh), Apparent Power (kVA), Apparent Energy (kVAh), Reactive Power (kVAR), Reactive Energy (kVARh), Power Factor (PF)			
Data Update Rate	1 Second			
<b>Communication</b>				
RS-485	Protocol	Modbus-RTU	-	-
	Baud rate	9600,19200 (default), 38400, 115200;		
	Data format	N,8,1 (default); N,8,2; E,8,1; E,8,2; O,8,1; O,8,2	-	-
	Isolation	3000 VDC	-	-
	Bias Resistor	No (Usually supplied by the RS-485 Master. Alternatively, add a tM-SG4 or SG-785)	-	-
Ethernet	Protocol	-	Modbus TCP	-
	PoE	-	Yes, IEEE 802.3af	
CAN Bus	Protocol	-	-	CANopen
	Baud rate	-	-	125 k,250k,500k and 1M
<b>Alarm Output</b>				
Power Relay	Form A (Normal Open) x 2; Relay Contact Voltage Range: 5 A @ 250 VAC (47 ~ 63Hz), 5 A @ 30 VDC			
<b>Power</b>				
Input Range	+12 ~ 48 VDC	+12 ~ 48 VDC/PoE	+12 ~ 48 VDC	
Power Consumption	2 W			
Dimensions (W x L x H)	127 mm x 105 mm x 33 mm			
<b>Environment</b>				
Operating Temperature	-20 ~ +70 °C			
Storage Temperature	-25 ~ +80 °C			