

I-7017, I-7018, I-7019, M-7017, M-7018 and M-7019 Series User Manual

Warranty

All products manufactured by ICP DAS are under warranty regarding defective materials for a period of one year from the date of delivery to the original purchaser.

Warning

ICP DAS assumes no liability for damages resulting from the use of this product. ICP DAS reserves the right to change this manual at any time without notification. The information furnished by ICP DAS is believed to be accurate and reliable. However, no responsibility is assumed by ICP DAS for its use, or for any infringements of patents or other rights of third parties resulting from its use.

Copyright

Copyright 1999 - 2013 ICP DAS. All rights reserved.

Trademark

The names used for identification only may be registered trademarks of their respective companies.

Date: 2020/12/22

Table of Contents

| | |
|--|----|
| 1. Introduction | 6 |
| 1.1 More Information | 9 |
| 1.2 Terminal Assignment | 10 |
| 1.3 Specifications | 19 |
| 1.4 Block Diagrams | 25 |
| 1.4.1 Block diagram for the I-7017, I-7017F, and M-7017 | 25 |
| 1.4.2 Block diagram for the I-7017C, I-7017FC and M-7017C ... | 25 |
| 1.4.3 Block diagram for the I-7017R and M-7017R | 26 |
| 1.4.4 Block diagram for the I-7017R-A5 and M-7017R-A5 | 26 |
| 1.4.5 Block diagram for the I-7017Z and M-7017Z | 27 |
| 1.4.6 Block diagram for the M-7017RMS | 27 |
| 1.4.7 Block diagram for the M-7017mC-16..... | 28 |
| 1.4.8 Block diagram for the I-7018, I-7018P and M-7018 | 28 |
| 1.4.9 Block diagram for the I-7018BL | 29 |
| 1.4.10 Block diagram for the I-7018R and M-7018R..... | 29 |
| 1.4.11 Block diagram for the I-7018Z and M-7018Z | 30 |
| 1.4.12 Block diagram for the M-7018-16 | 30 |
| 1.4.13 Block diagram for the I-7019R and M-7019R..... | 31 |
| 1.4.14 Block diagram for the M-7019Z | 31 |
| 1.5 Dimensions | 32 |
| 1.5.1 Modules without Frame Ground | 32 |
| 1.5.2 Modules with Frame Ground | 33 |
| 1.5.3 M-7017mC-16 and M-7018-16..... | 34 |
| 1.6 Wiring Diagrams | 35 |
| 1.6.1 Wiring diagram for the I-7017, I-7017F, I-7017R, M-7017 and M-7017R..... | 35 |
| 1.6.2 Wiring diagram for the I-7017C, I-7017FC, I-7017RC, M- 7017C and M-7017RC | 36 |
| 1.6.3 Wiring diagram for the I-7017R-A5 and M-7017R-A5..... | 36 |
| 1.6.4 Wiring diagram for the I-7017Z and M-7017Z..... | 36 |
| 1.6.5 Wiring diagram for the M-7017RMS..... | 36 |
| 1.6.6 Wiring diagram for the M-7017mC-16..... | 37 |
| 1.6.7 Wiring diagram for the I-7018, I-7018P, I-7018BL, I-7018R, I-7018Z, M-7018, M-7018R and M-7018Z | 37 |
| 1.6.8 Wiring diagram for the M-7018-16..... | 38 |
| 1.6.9 Wiring diagram for the I-7019R, M-7019R and M-7019Z.. | 39 |
| 1.7 Jumper Settings | 40 |
| 1.7.1 I-7017, I-7017F, I-7018, I-7018P and I-7018BL Jumper Settings | 40 |

| | |
|--|-----|
| 1.7.2 I-7017, I-7017F, I-7017C, I-7017FC, M-7017 and M-7017C Jumper Settings | 41 |
| 1.7.3 I-7017R, I-7017RC, M-7017R, M-7017RC, I-7018R and M- 7018R Jumper Settings..... | 43 |
| 1.7.4 I-7018, I-7018P, I-7018BL and M-7018 Jumper Settings ... | 44 |
| 1.7.5 I-7019R and M-7019R Jumper Settings..... | 46 |
| 1.7.6 M-7019Z Jumper Settings | 49 |
| 1.7.7 I-7017Z and M-7017Z Jumper Settings | 50 |
| 1.7.8 M-7017mC-16 Jumper Settings | 52 |
| 1.7.9 M-7018-16 Jumper Settings | 54 |
| 1.8 Quick Start..... | 55 |
| 1.9 Default Settings | 57 |
| 1.10 Calibration | 59 |
| 1.11 Configuration Tables..... | 62 |
| 1.12 M-7000 Notes..... | 72 |
| 1.12.1 Protocol Switching | 72 |
| 1.12.2 INIT Mode..... | 73 |
| 1.13 Mounting | 74 |
| 1.13.1 DIN Rail Mounting | 74 |
| 1.13.2 Piggyback Mounting | 76 |
| 1.13.3 Wall Mounting..... | 77 |
| 1.14 Technical Support..... | 78 |
| 2. DCON Protocol..... | 79 |
| 2.1 %AANNTTCCFF | 83 |
| 2.2 #** | 87 |
| 2.3 #AA | 89 |
| 2.4 #AAN, #AANN..... | 91 |
| 2.5 \$AA0 | 93 |
| 2.6 \$AA1 | 95 |
| 2.7 \$AA0Ci..... | 97 |
| 2.8 \$AA0Ci..... | 99 |
| 2.9 \$AA1Ci..... | 101 |
| 2.10 \$AA2 | 103 |
| 2.11 \$AA3 | 105 |
| 2.12 \$AA4 | 107 |
| 2.13 \$AA5VV, \$AA5VVVV | 109 |
| 2.14 \$AA6 | 111 |
| 2.15 \$AA7CiRrr | 113 |
| 2.16 \$AA8Ci | 116 |
| 2.17 \$AA9 | 118 |
| 2.18 \$AA9SNNNN | 120 |
| 2.19 \$AAA | 122 |
| 2.20 \$AAA | 124 |

| | |
|--|-----|
| 2.21 \$AAAi | 126 |
| 2.22 \$AAB..... | 128 |
| 2.23 \$AAF | 130 |
| 2.24 \$AAM..... | 131 |
| 2.25 \$AAP | 133 |
| 2.26 \$AAPN | 135 |
| 2.27 \$AAS0 | 137 |
| 2.28 \$AAS1 | 139 |
| 2.29 ~AAC | 141 |
| 2.30 ~AACN..... | 143 |
| 2.31 ~AAEV..... | 145 |
| 2.32 ~AAI..... | 147 |
| 2.33 ~AAO(Name) | 149 |
| 2.34 ~AATnn..... | 151 |
| 2.35 ~** | 154 |
| 2.36 ~AA0 | 155 |
| 2.37 ~AA1 | 157 |
| 2.38 ~AA2 | 159 |
| 2.39 ~AA3EVV | 161 |
| 2.40 ~AAEO..... | 163 |
| 2.41 ~AAEON..... | 165 |
| 2.42 @AAS | 167 |
| 2.43 @AASN | 169 |
| 3. Modbus RTU Protocol | 171 |
| 3.1 02 (0x02) Read Input Status..... | 172 |
| 3.2 04 (0x04) Read Input Channels..... | 173 |
| 3.3 70 (0x46) Read/Write Module Settings | 174 |
| 3.3.1 Sub-function 00 (0x00) Read module name | 175 |
| 3.3.2 Sub-function 04 (0x04) Set module address | 176 |
| 3.3.3 Sub-function 05 (0x05) Read communication settings..... | 177 |
| 3.3.4 Sub-function 06 (0x06) Set communication settings..... | 178 |
| 3.3.5 Sub-function 07 (0x07) Read type code..... | 179 |
| 3.3.6 Sub-function 08 (0x08) Set type code..... | 180 |
| 3.3.7 Sub-function 32 (0x20) Read firmware version..... | 181 |
| 3.3.8 Sub-function 37 (0x25) Read channel enabled/disabled status | 182 |
| 3.3.9 Sub-function 38 (0x26) Set channel enable/disable..... | 183 |
| 3.3.10 Sub-function 41 (0x29) Read miscellaneous settings | 184 |
| 3.3.11 Sub-function 42 (0x2A) Write miscellaneous settings | 185 |
| 3.3.12 Sub-function 43 (0x2B) Read CJC offset | 186 |
| 3.3.13 Sub-function 44 (0x2C) Write CJC offset | 187 |
| 3.3.14 Sub-function 45 (0x2D) Read CJC enabled/disabled status | 188 |

| | |
|--|-----|
| 3.3.15 Sub-function 46 (0x2E) Set CJC enable/disable | 189 |
| 3.3.16 Sub-function 47 (0x2F) Read CJC update setting..... | 190 |
| 3.3.17 Sub-function 48 (0x30) Write CJC update setting | 191 |
| 3.4 Address Mappings | 192 |
| 3.4.1 M-7017 Series Address Mappings (Base 1)..... | 192 |
| 3.4.2 M-7017RMS Address Mappings (Base 1) | 194 |
| 3.4.3 M-7017mC-16 Address Mappings (Base 1) | 196 |
| 3.4.4 M-7017Z Address Mappings (Base 1) | 200 |
| 3.4.5 M-7018 Series Address Mappings (Base 1)..... | 202 |
| 3.4.6 M-7018Z Address Mappings (Base 1) | 204 |
| 3.4.7 M-7018-16 Address Mappings (Base 1) | 206 |
| 3.4.8 M-7019R Address Mappings (Base 1)..... | 208 |
| 3.4.9 M-7019Z Address Mappings (Base 1) | 211 |
| 3.5 Engineering Data Format Table | 213 |
| 4. Troubleshooting | 215 |
| 4.1 Communicating with the module | 216 |
| 4.2 Reading Data | 217 |
| A. Appendix | 218 |
| A.1 INIT Mode..... | 218 |
| A.2 Dual Watchdog Operation..... | 220 |
| A.3 Thermocouple..... | 221 |
| A.4 Frame Ground..... | 222 |
| A.5 Hexadecimal Data Conversion..... | 224 |

1. Introduction

The I-7000 series is a family of network data acquisition and control modules, providing analog-to-digital, digital-to-analog, digital input/output, timer/counter and other functions. The modules can be remotely controlled using a set of commands, which we call the DCON protocol. Communication between the module and the host is in ASCII format via an RS-485 bi-directional serial bus standard. Baud Rates are software programmable and transmission speeds of up to 115.2K baud can be selected.

The functionality of the M-7000 series is the same as the I-7000 series, with the exception that the M-7000 series offers extended support for the Modbus RTU protocol.

Some I-7000 and all M-7000 modules feature a new design for the frame ground and INIT switch as shown in the figure (rear view). The frame ground provides enhanced static protection (ESD) abilities and ensures the module is more reliable. The INIT switch allows INIT mode to be accessed more easily. Refer to Sections A.1 and A.4 for more details.

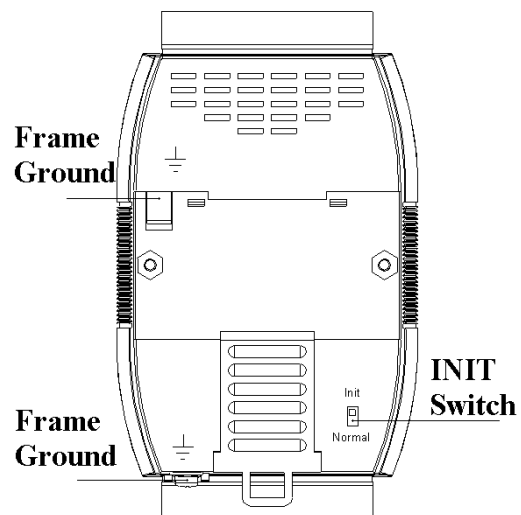

The common features of the I-7017, I-7018 and I-7019 are as follows:

1. 3000V DC inter-module isolation

2. 24-bit sigma-delta ADC to provide excellent accuracy
3. Software calibration

The I-7017 is an 8-channel voltage and current input module. The I-7018 is an 8-channel voltage, current and thermocouple input module. The I-7019 is an 8-channel voltage, current, and thermocouple input module, with the ability to connect various types of inputs to a single module.

The I-7017 has the following variations:

- I-7017F: added support for fast mode, 60 samples/second.
- I-7017C: used for current input only, with no external resistor required.
- I-7017FC: used for current input only, with no external resistor required. Added support for fast mode, 60 samples/second.
- I-7017R: added high voltage overload protection, 240Vrms.
- I-7017RC: used for current input only, with no external resistor required. Added high voltage overload protection, 240Vrms.
- I-7017R-A5: used for high voltage input
- I-7017Z: 10 channels, added high voltage overload protection, 240Vrms
- M-7017RMS: used for AC input
- M-7017mC-16: used for current input only, with no external resistor required. Added high voltage overload protection, 110V_{DC}, and data logger.

The I-7018 has the following variations:

- M-7018-16: 16 channels, added thermocouple wire opening detection
- I-7018P: added support for two additional thermocouple types, L and M
- I-7018BL: only support thermocouple types and with thermocouple wire opening detection
- I-7018R: added thermocouple wire opening detection and high voltage overload protection, 240Vrms
- I-7018Z: 10 channels, added thermocouple wire opening detection and high voltage overload protection, 240Vrms

The I-7019 has the following variation:

- I-7019R: added high voltage overload protection, 240Vrms
- M-7019Z: 10 channels, added high voltage overload protection, 240Vrms

The I-7017R, I-7017RC, I-7017Z, I-7018R, I-7018Z, I-7019R and M-7019Z modules are designed for industrial plant environments and have special input circuits to provide 240Vrms continuous overload protection as shown in the figure.

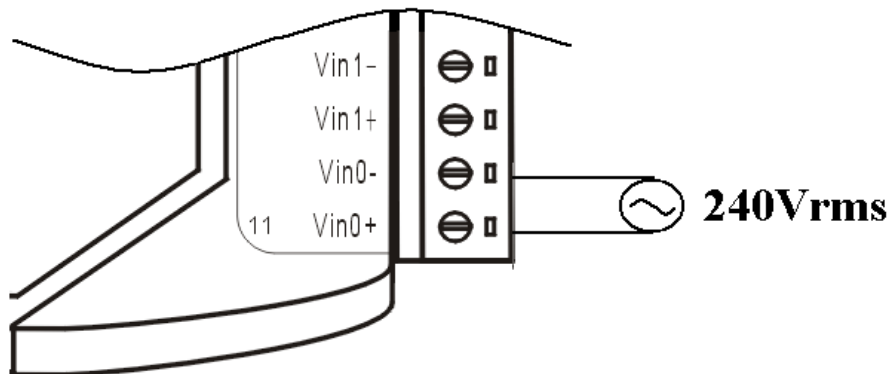

1.1 More Information

Refer to chapter 1 of the “I-7000 Bus Converter User’s Manual” as shown below or visit the ICP DAS website <http://www.icpdas.com> for more information regarding the I-7000 series.

- 1.1 The I-7000 Series Overview
- 1.2 Related Documentation for the I-7000 Series
- 1.3 Common Features of the I-7000 Series
- 1.4 The I-7000 Series System Network Configuration
- 1.5 I-7000 Dimensions

1.2 Terminal Assignment

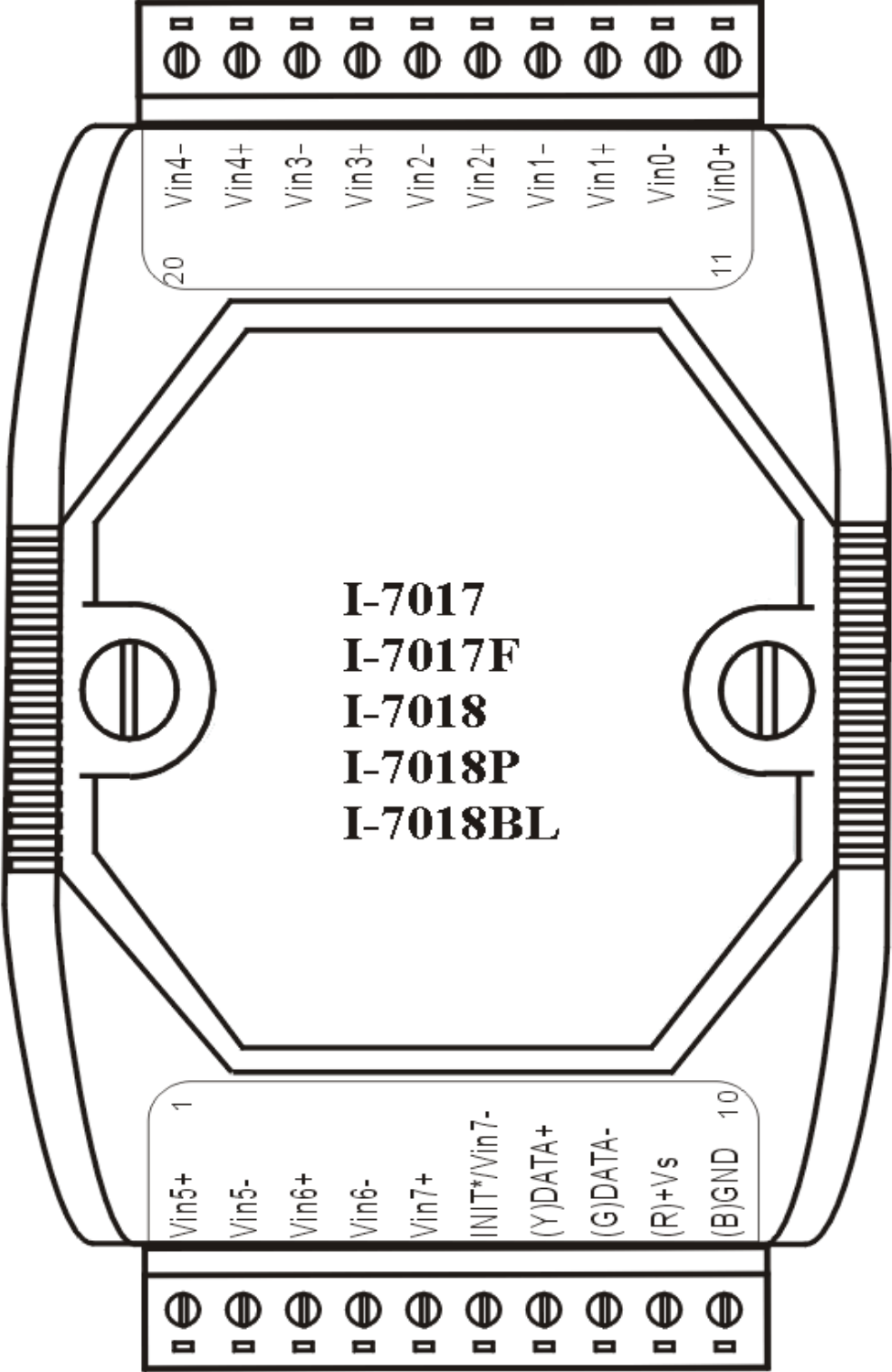

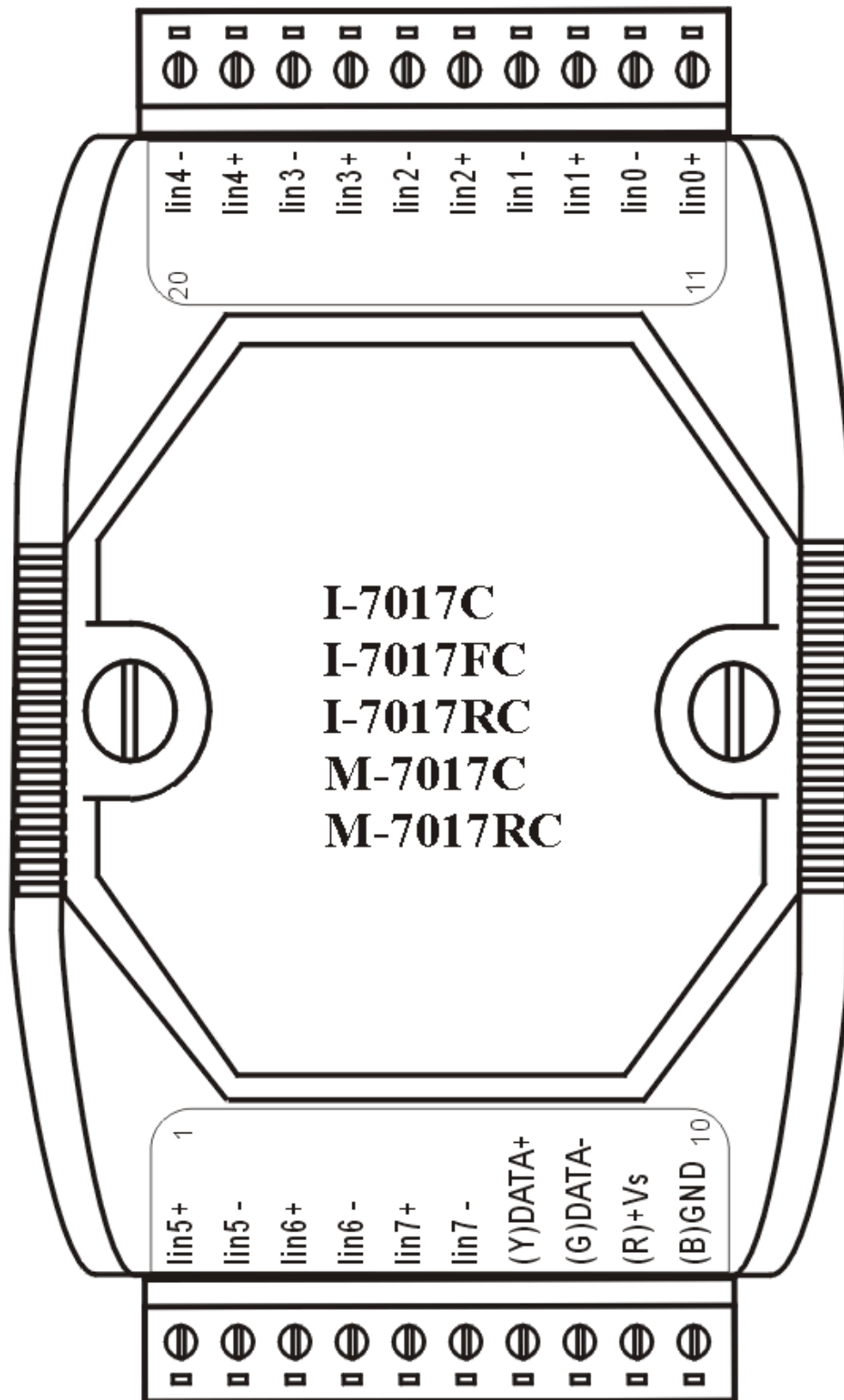

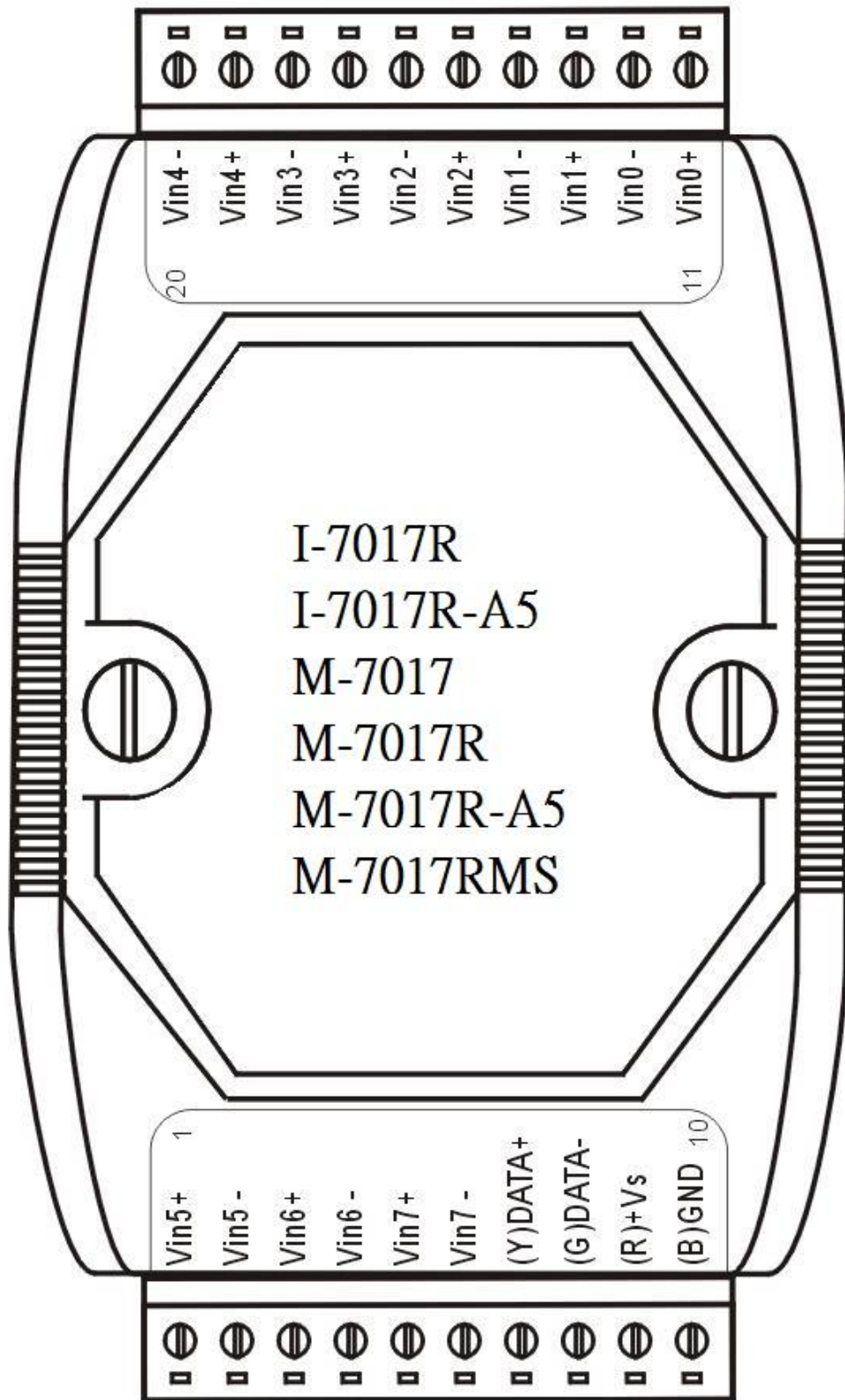

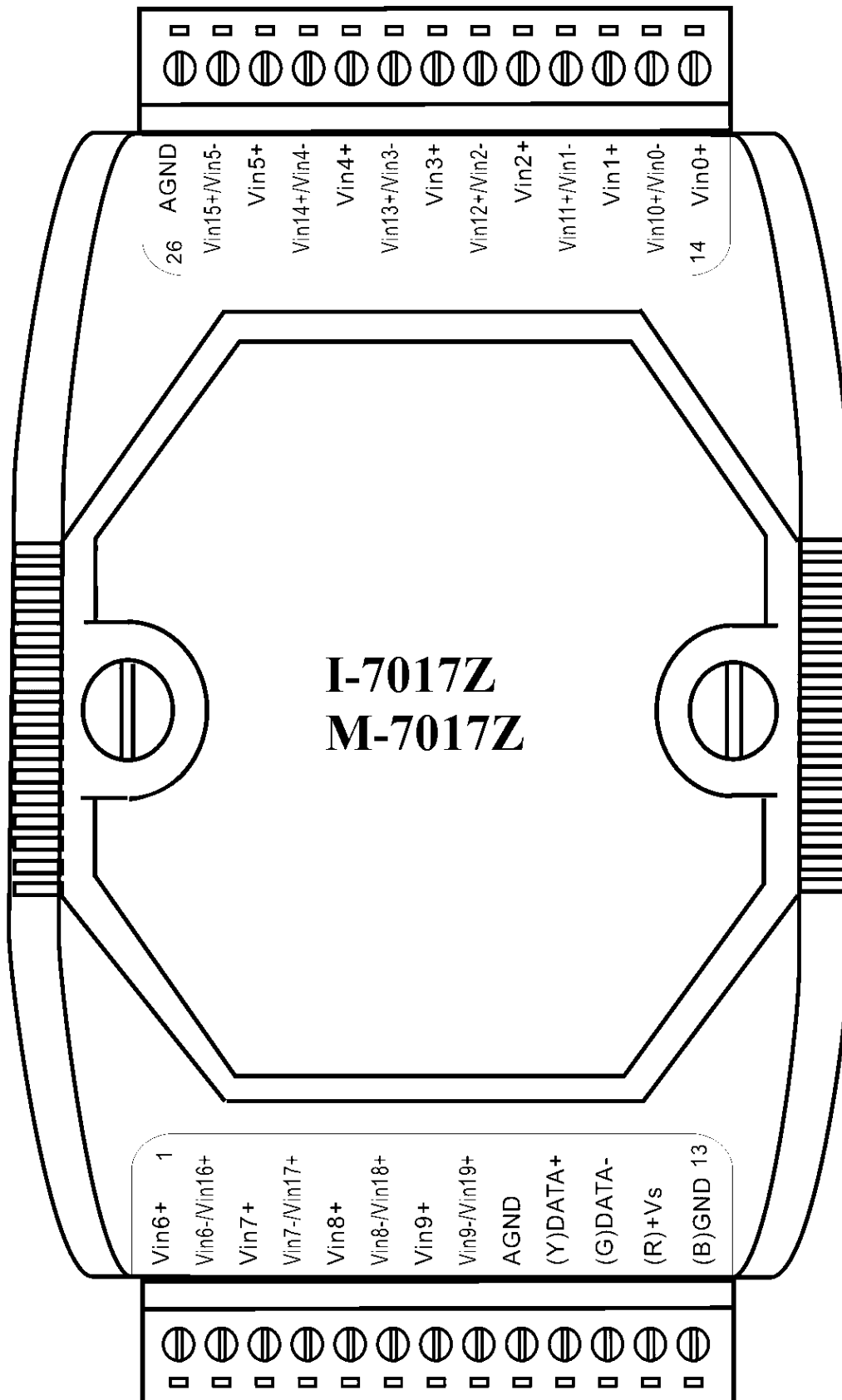

M-7017mC-16

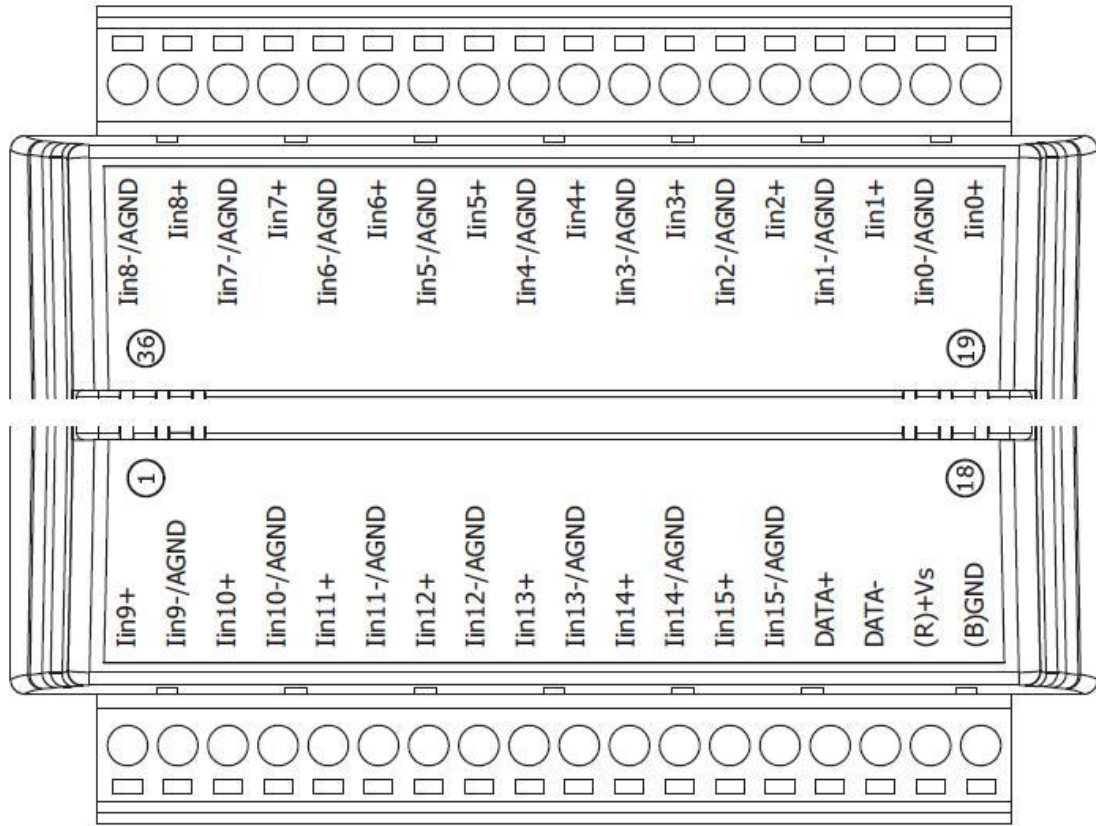

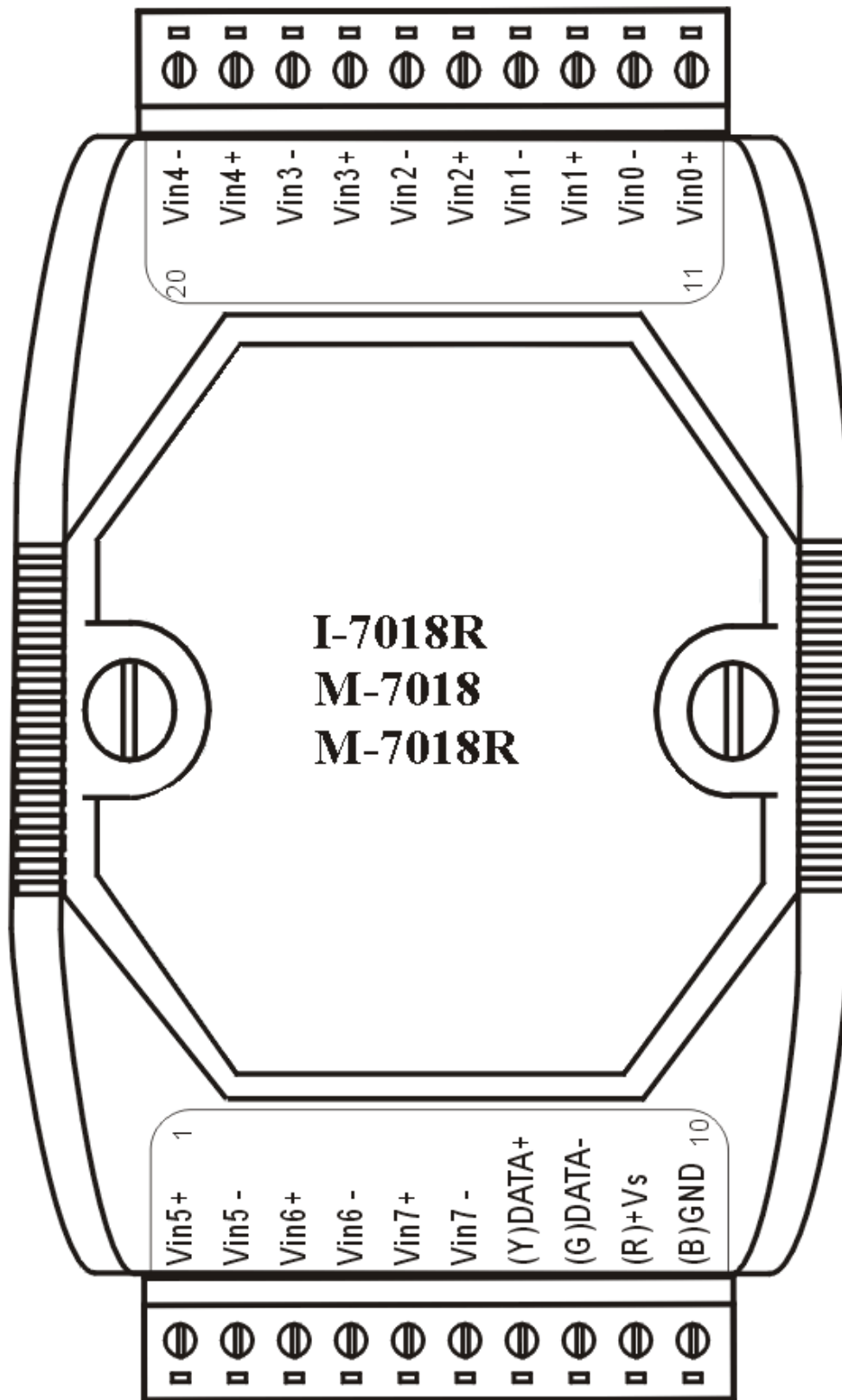

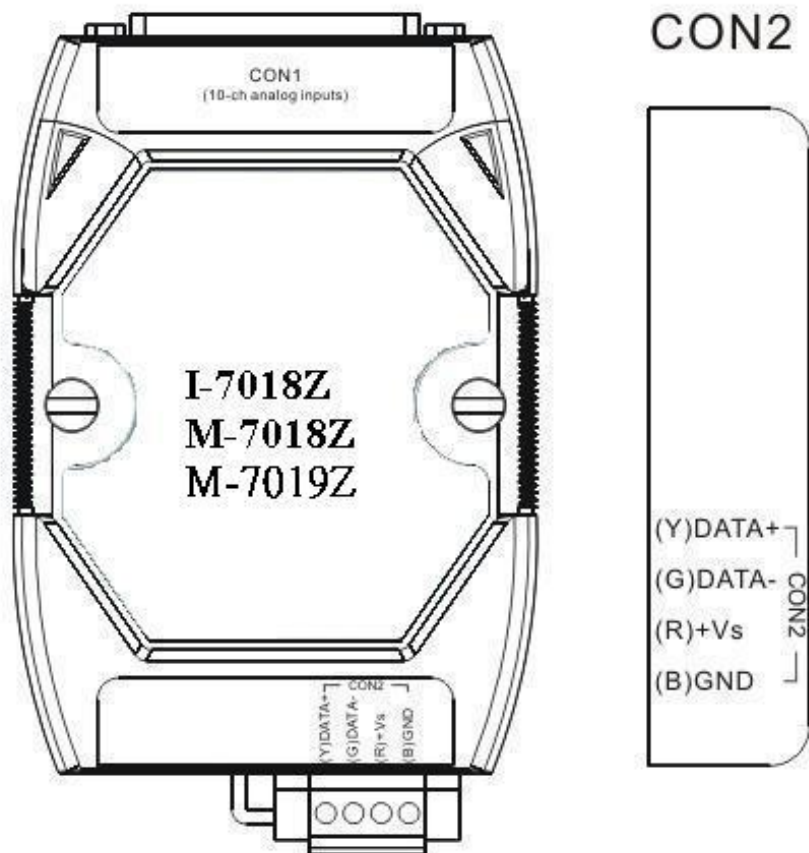
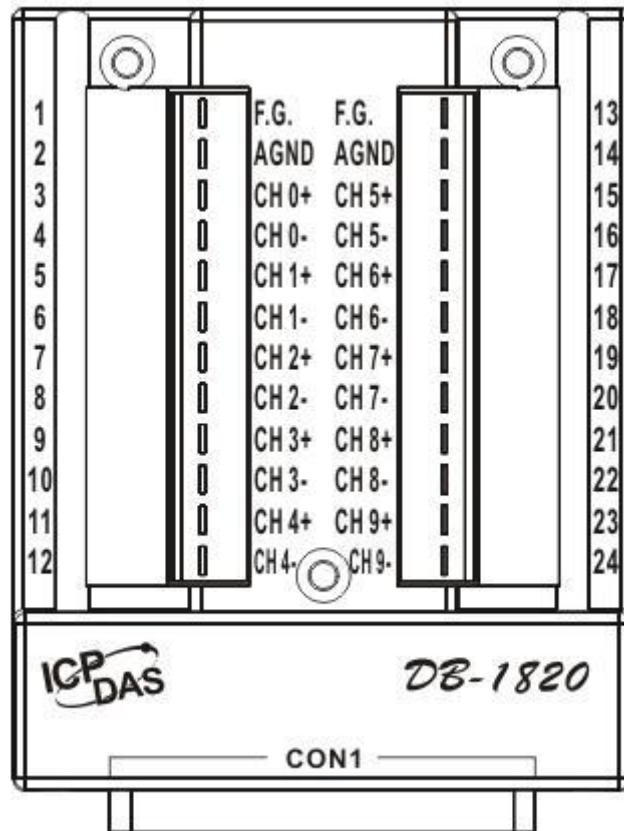

M-7018-16

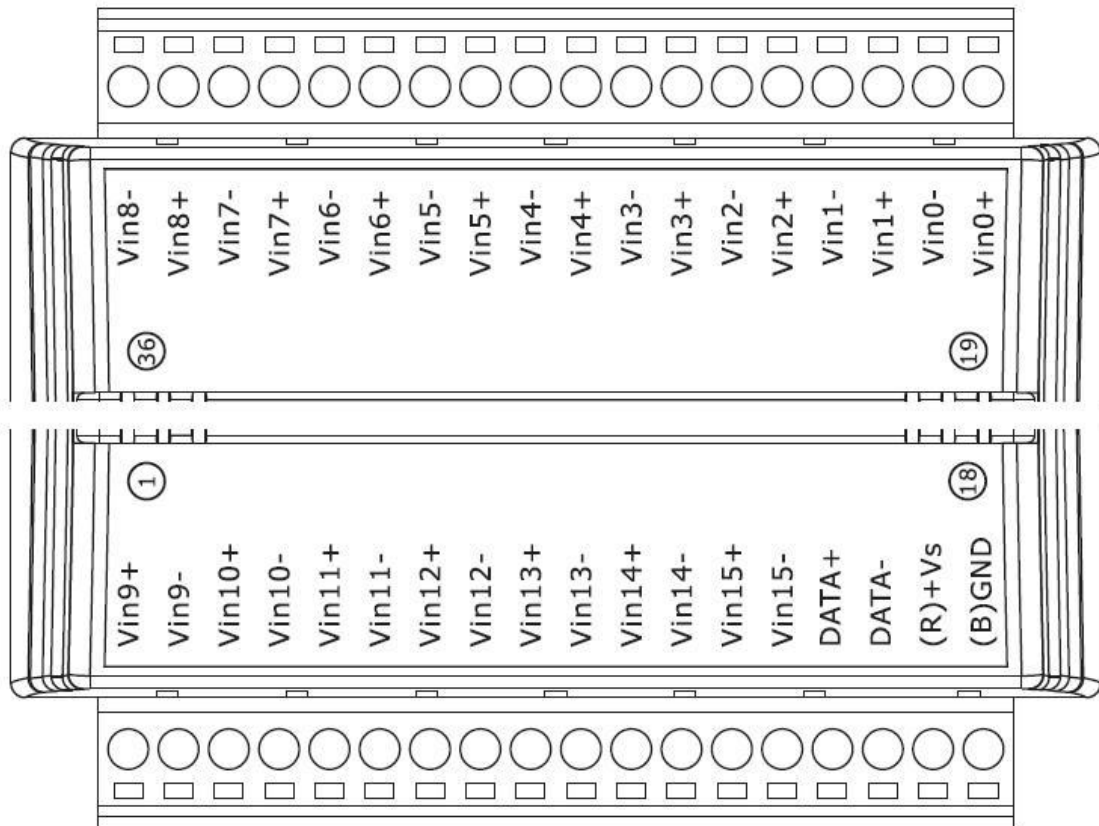

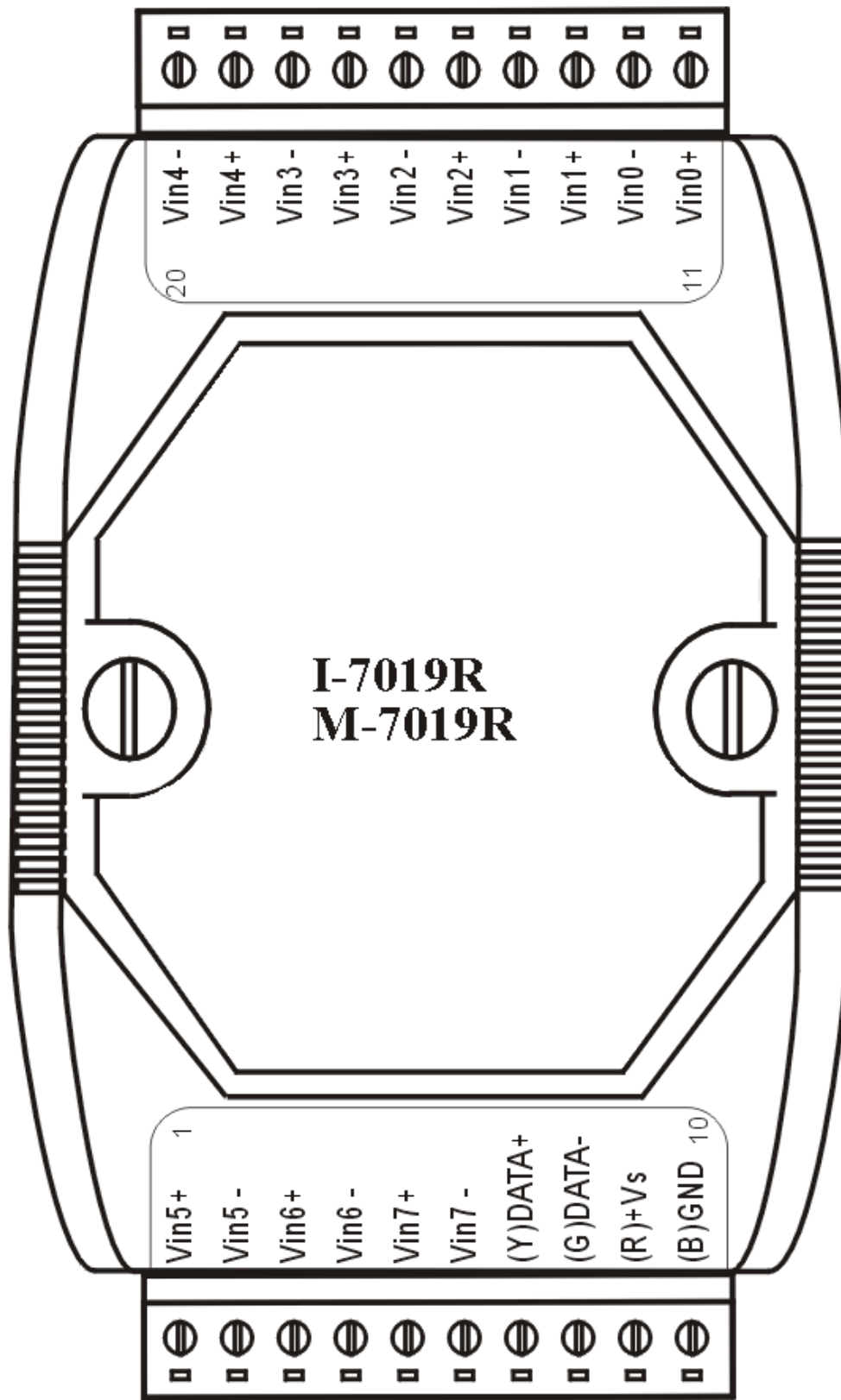

1.3 Specifications

| | I-7017/M-7017 | I-7017F/I-7017R M-7017R | I-7017C^{*3}/I-7017FC/I-7017RC M-7017C^{*3}/M-7017RC |
|-----------------------------|------------------------------|---|---|
| Analog Input | | | |
| Input Channels | 8 differential ^{*1} | 8 differential ^{*1} | 8 differential |
| Input Type | mV, V, mA ^{*2} | mV, V, mA ^{*2} | mA |
| Sampling Rate | 10 samples/sec | 10 samples/sec (normal) 60 samples/sec (fast) | 10 samples/sec (normal) 60 samples/sec (fast) |
| Bandwidth | 15.7Hz | 15.7Hz (normal) 78.7Hz (fast) | 15.7Hz (normal) 78.7Hz (fast) |
| Accuracy | ±0.1% of FSR | ±0.1% of FSR (normal) ±0.5% of FSR (fast) | ±0.1% of FSR (normal) ±0.5% of FSR (fast) |
| Zero Drift | 20µV/°C | 20µV/°C | 20µV/°C |
| Span Drift | 25ppm/°C | 25ppm/°C | 25ppm/°C |
| Input Impedance | 20MΩ | I-7017R/M-7017R 1MΩ I-7017F 20MΩ | 125Ω |
| Voltage overload Protection | ±120V | I-7017R/M-7017R ±240V I-7017F ±120V | I-7017RC/M-7017RC 50mA at 110VDC I-7017C/FC/M-7017C 50mA at 110VDC |
| Isolation | 3000V DC | 3000V DC | 3000V DC |
| Modbus RTU | M-7017 | M-7017R | M-7017C/M-7017RC |
| Power | | | |
| Requirement | +10 to +30V DC | +10 to +30V DC | +10 to +30V DC |
| Consumption | 1.3W | 1.3W | 1.3W |
| Temperature Range | | | |
| Operating | -25°C to +75°C | -25°C to +75°C | -25°C to +75°C |
| Storage | -30°C to +75°C | -30°C to +75°C | -30°C to +75°C |

*1: For I-7017 and I-7017F, the number of input channels is 8 differential or 6 differential and 2 single-ended by jumper selection.

*2: requires optional external 125 ohm resistor.

*3: I-7017C and M-7017C does not support fast mode, 60 samples/sec sampling rate.

Note: A warm up period of 30 minutes is recommended in order to achieve the complete performance results described in the specifications.

| | I-7017R-A5 M-7017R-A5 | I-7017Z M-7017Z |
|---------------------------------|--|--|
| Analog Input | | |
| Input Channels | 8 differential | 10 differential/20 single-ended |
| Input Type | V | mV, V, mA (jumper selectable) |
| Sampling Rate | 10 samples/sec (normal) 50 samples/sec (fast) | 10 samples/sec (normal) 60 samples/sec (fast) |
| Bandwidth | 15.7Hz (normal) 78.7Hz (fast) | 15.7Hz (normal) 78.7Hz (fast) |
| Accuracy | ±0.1% of FSR (normal) ±0.25% of FSR (fast) | ±0.1% of FSR (normal) ±0.5% of FSR (fast) |
| Zero Drift | 20µV/°C | 20µV/°C |
| Span Drift | 25ppm/°C | 25ppm/°C |
| Input Impedance | 290KΩ | Differential: 2MΩ Single-ended: 1MΩ |
| Current Impedance | | 125Ω, 1/4W |
| Voltage overload Protection | ±200V | Differential: ±240V Single-ended: ±150V |
| Isolation | 3000V DC | 3000V DC |
| Individual Channel Configurable | No | Yes |
| Modbus RTU | M-7017R-A5 | M-7017Z |
| Power | | |
| Requirement | +10 to +30V DC | +10 to +30V DC |
| Consumption | 1.7W | 2.0W |
| Temperature Range | | |
| Operating | -25°C to +75°C | -25°C to +75°C |
| Storage | -30°C to +75°C | -30°C to +75°C |

Note: A warm up period of 30 minutes is recommended in order to achieve the complete performance results described in the specifications.

| | M-7017RMS | M-7017mC-16 |
|---------------------------------|--|--|
| Analog Input | | |
| Input Channels | 8 differential | 16 differential or single-ended |
| Input Type | Vrms | mA |
| Sampling Rate | 10 samples/sec | 10 samples/sec (normal) 200 samples/sec (fast) |
| Bandwidth | 15.7Hz | |
| Accuracy | Sinusoid: 50/60Hz: $\pm 0.15\%$ of FSR 45Hz to 10kHz: $\pm 0.5\%$ of FSR Non-sinusoid: Crest factor 1 to 2: $\pm 0.2\%$ of FSR Crest factor 2 to 3: $\pm 0.35\%$ of FSR DC 0 to 10V, 0 to 5V and 0 to 1V: $\pm 0.3\%$ of FSR 0 to 500mV and 0 to 150mV: $\pm 0.7\%$ of FSR | $\pm 0.1\%$ of FSR (normal) $\pm 0.2\%$ of FSR (fast) |
| Zero Drift | 20 μ V/ $^{\circ}$ C | 20 μ V/ $^{\circ}$ C |
| Span Drift | 25ppm/ $^{\circ}$ C | 25ppm/ $^{\circ}$ C |
| Input Impedance | 2M Ω | 125 Ω |
| Voltage overload Protection | ± 35 V | 110 VDC |
| Isolation | 3000V DC | 3000V DC |
| Individual Channel Configurable | Yes | Yes |
| Modbus RTU | M-7017RMS | M-7017mC-16 |
| Power | | |
| Requirement | +10 to +30V DC | +10 to +48V DC |
| Consumption | 0.9W | 0.6W |
| Temperature Range | | |
| Operating | -25 $^{\circ}$ C to +75 $^{\circ}$ C | -25 $^{\circ}$ C to +75 $^{\circ}$ C |
| Storage | -30 $^{\circ}$ C to +75 $^{\circ}$ C | -30 $^{\circ}$ C to +75 $^{\circ}$ C |

Note: A warm up period of 30 minutes is recommended in order to achieve the complete performance results described in the specifications.

| | I-7018 M-7018 | I-7018P/I-7018Z M-7018Z | I-7018R M-7018R |
|--|------------------------------|---|------------------------------|
| Analog Input | | | |
| Input Channels | 8 differential ^{*1} | 8 diff ^{*1} (10 for 7018Z) | 8 differential ^{*1} |
| Input Type | mV, V, mA ^{*2} | mV, V, mA ^{*2} | mV, V, mA ^{*2} |
| Thermocouple Type | J, K, T, E, R, S, B, N, C | J, K, T, E, R, S, B, N, C, L, M | J, K, T, E, R, S, B, N, C |
| Sampling Rate | 10 samples/sec | 10 samples/sec | 10 samples/sec |
| Bandwidth | 15.7Hz | 15.7Hz | 15.7Hz |
| Accuracy | ±0.1% of FSR | ±0.1% of FSR | ±0.2% of FSR |
| Zero Drift | 0.5µV/°C | 0.5µV/°C | 10µV/°C |
| Span Drift | 25ppm/°C | 25ppm/°C | 25ppm/°C |
| Input Impedance | 20MΩ | 20MΩ | 1MΩ |
| Voltage overload Protection | ±80V | I-7018Z/M-7018Z ±240V I-7018P ±80V | ±240V |
| Isolation | 3000V DC | 3000V DC | 3000V DC |
| Open Wire Detection | No | Yes for I-7018Z/ M-7018Z | Yes |
| Modbus RTU | M-7018 | M-7018Z | M-7018R |
| Power | | | |
| Requirement | +10 to +30V DC | +10 to +30V DC | +10 to +30V DC |
| Consumption | 1.0W | 1.0W | 1.0W |
| Temperature Range | | | |
| Operating | -25°C to +75°C | -25°C to +75°C | -25°C to +75°C |
| Storage | -30°C to +75°C | -30°C to +75°C | -30°C to +75°C |
| *1: For I-7018, I-7018P and I-7018BL, the number of input channels is 8 differential or 6 differential and 2 single-ended by jumper selection. | | | |
| *2: requires optional external 125 ohm resistor | | | |
| *3: I-7018Z and M-7018Z are individual channel configurable. | | | |

Note: A warm up period of 30 minutes is recommended in order to achieve the complete performance results described in the specifications.

| | M-7018-16 | I-7018BL | |
|--|---------------------------|------------------------------|--|
| Analog Input | | | |
| Input Channels | 16 differential | 8 differential ^{*2} | |
| Input Type | mV, V, mA ^{*1} | | |
| Thermocouple Type | J, K, T, E, R, S, B, N, C | J, K, T, E, R, S, B, N, C | |
| Sampling Rate | 10 samples/sec | 10 samples/sec | |
| Bandwidth | 15.7Hz | 15.7Hz | |
| Accuracy | ±0.1% of FSR | ±0.1% of FSR | |
| Input Impedance | > 400KΩ | 20MΩ | |
| Voltage overload Protection | ±30V | ±35V | |
| Isolation | 3000V DC | 3000V DC | |
| Open Wire Detection | Yes | Yes | |
| Modbus RTU | M-7018-16 | | |
| Power | | | |
| Requirement | +10 to +30V DC | +10 to +30V DC | |
| Consumption | 1.0W | 1.0W | |
| Temperature Range | | | |
| Operating | -25°C to +75°C | -25°C to +75°C | |
| Storage | -30°C to +75°C | -30°C to +75°C | |
| *1: requires optional external 125 ohm resistor | | | |
| *2: For I-7018BL, the number of input channels is 8 differential or 6 differential and 2 single-ended by jumper selection. | | | |

Note: A warm up period of 30 minutes is recommended in order to achieve the complete performance results described in the specifications.

| | I-7019R/M-7019R | M-7019Z |
|---------------------------------|--|-----------------|
| Analog Input | | |
| Input Channels | 8 differential | 10 differential |
| Input Type | mV, V, mA (jumper selectable) | |
| Thermocouple Type | J, K, T, E, R, S, B, N, C, L, M, LDIN43710 | |
| Sampling Rate | 8 samples/sec | 10 samples/sec |
| Bandwidth | 5.24Hz | |
| Accuracy | ±0.1% of FSR | |
| Zero Drift | 10µV/°C for +/-10 V and +/-5 V types 0.5µV/°C for other types | |
| Span Drift | 25ppm/°C | |
| Input Impedance | 2MΩ | |
| Current Impedance | 125Ω, 1/4W | |
| Voltage overload Protection | ±240V | |
| Isolation | 3000V DC | |
| Open Wire Detection | Yes | |
| Individual Channel Configurable | Yes | |
| Modbus RTU | M-7019R | M-7019Z |
| Power | | |
| Requirement | +10 to +30V DC | |
| Consumption | 1.2W | 1.8W |
| Temperature Range | | |
| Operating | -25°C to +75°C | |
| Storage | -30°C to +75°C | |

Note: A warm up period of 30 minutes is recommended in order to achieve the complete performance results described in the specifications.

1.4 Block Diagrams

1.4.1 Block diagram for the I-7017, I-7017F, and M-7017

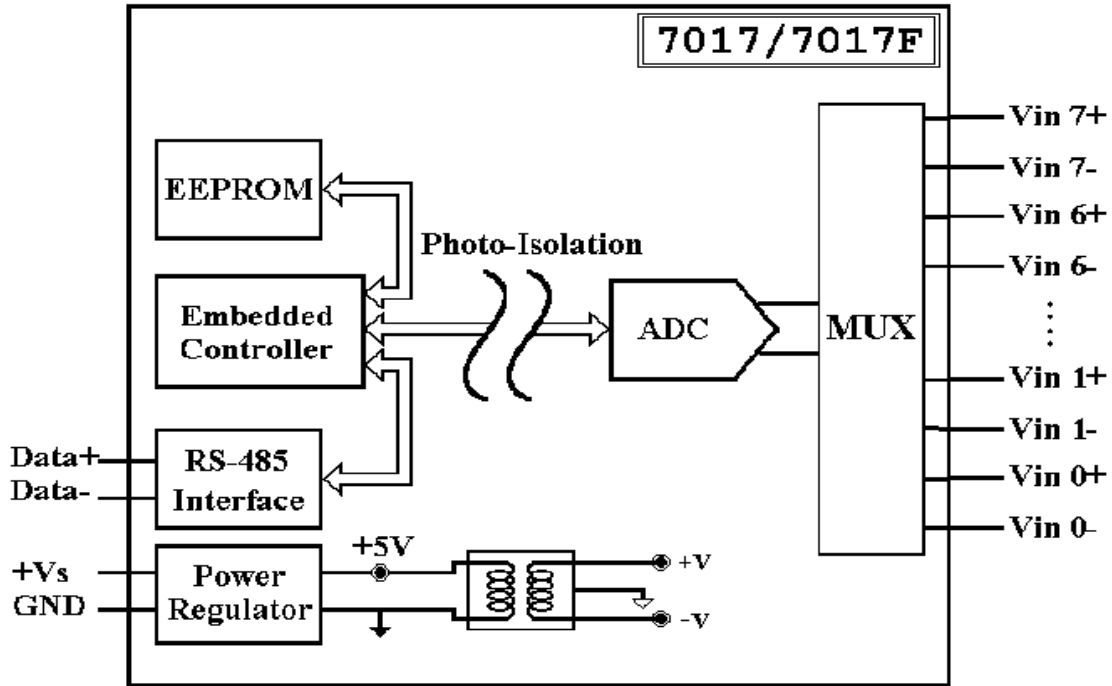

1.4.2 Block diagram for the I-7017C, I-7017FC and M-7017C

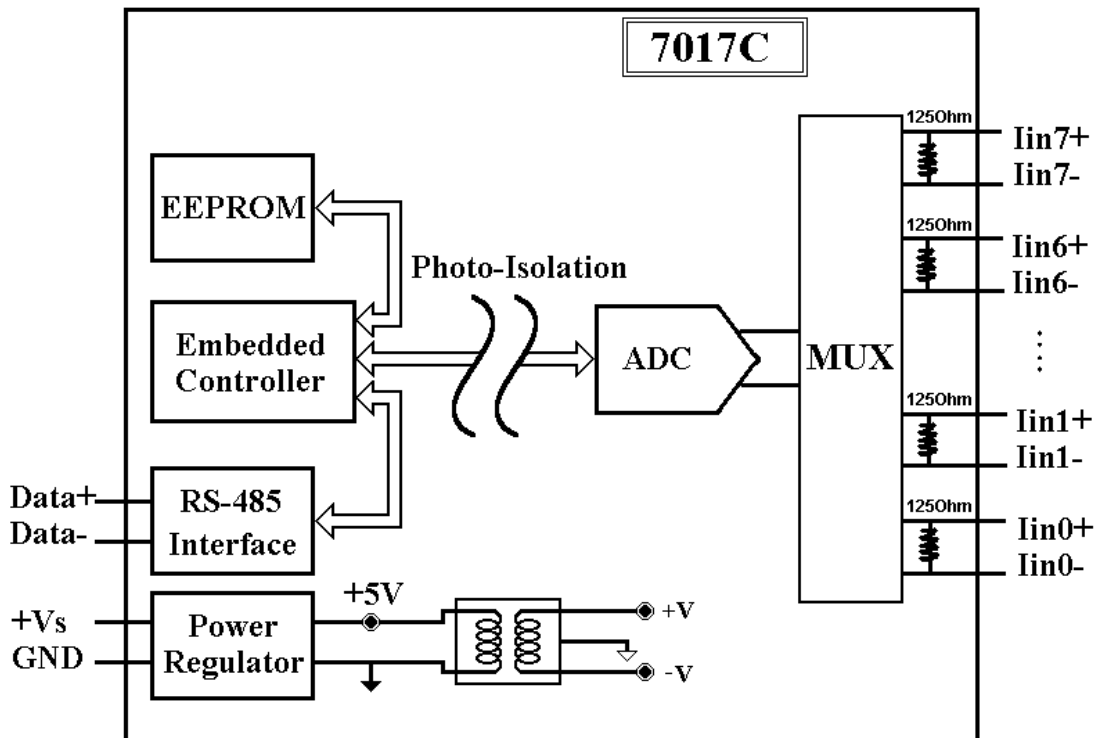

1.4.3 Block diagram for the I-7017R and M-7017R

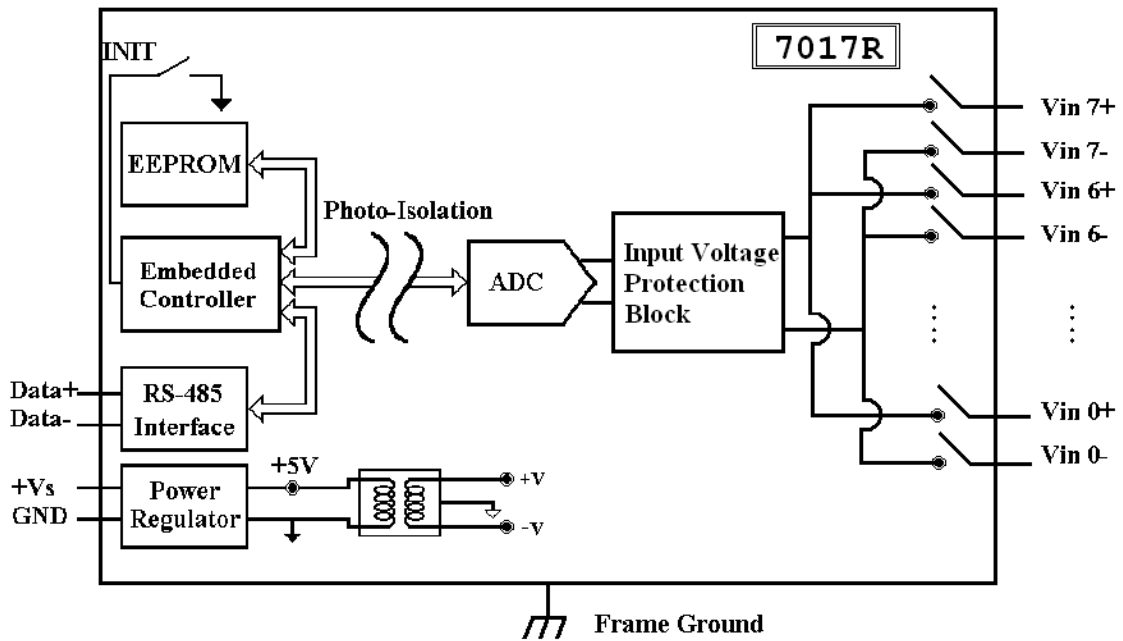

1.4.4 Block diagram for the I-7017R-A5 and M-7017R-A5

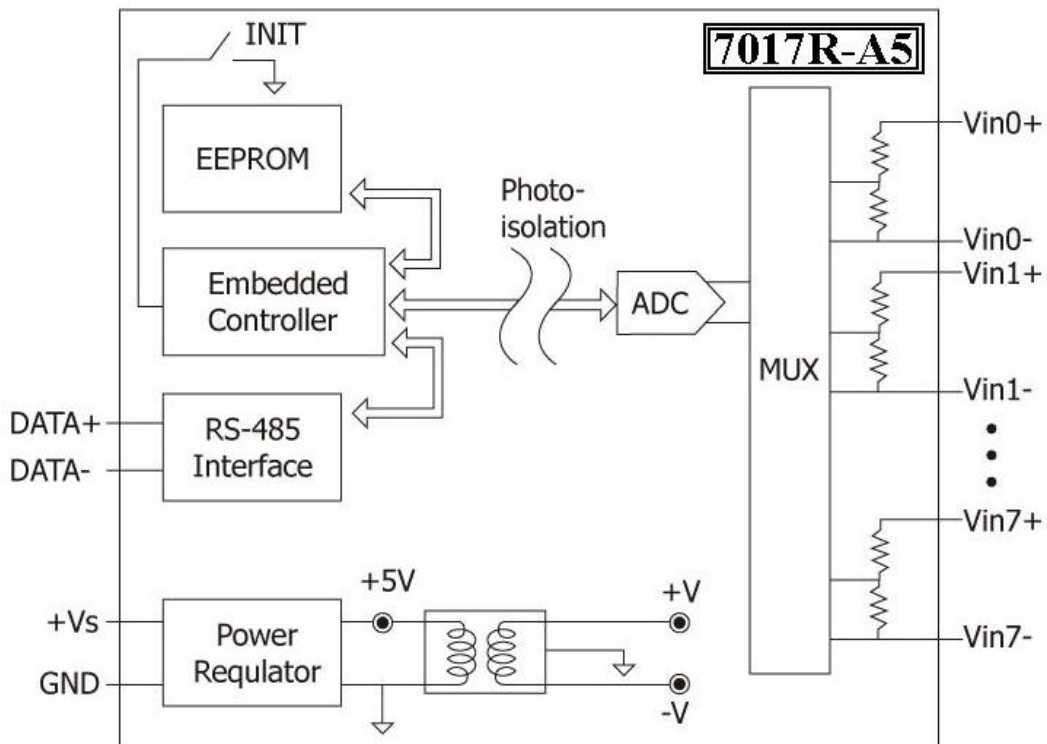

1.4.5 Block diagram for the I-7017Z and M-7017Z

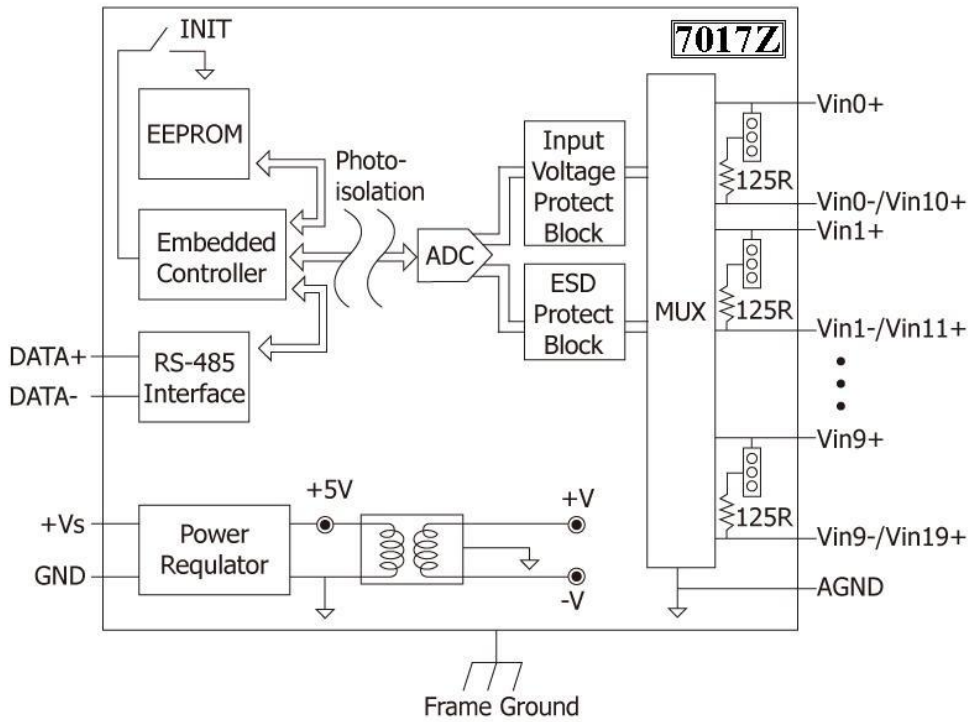

1.4.6 Block diagram for the M-7017RMS

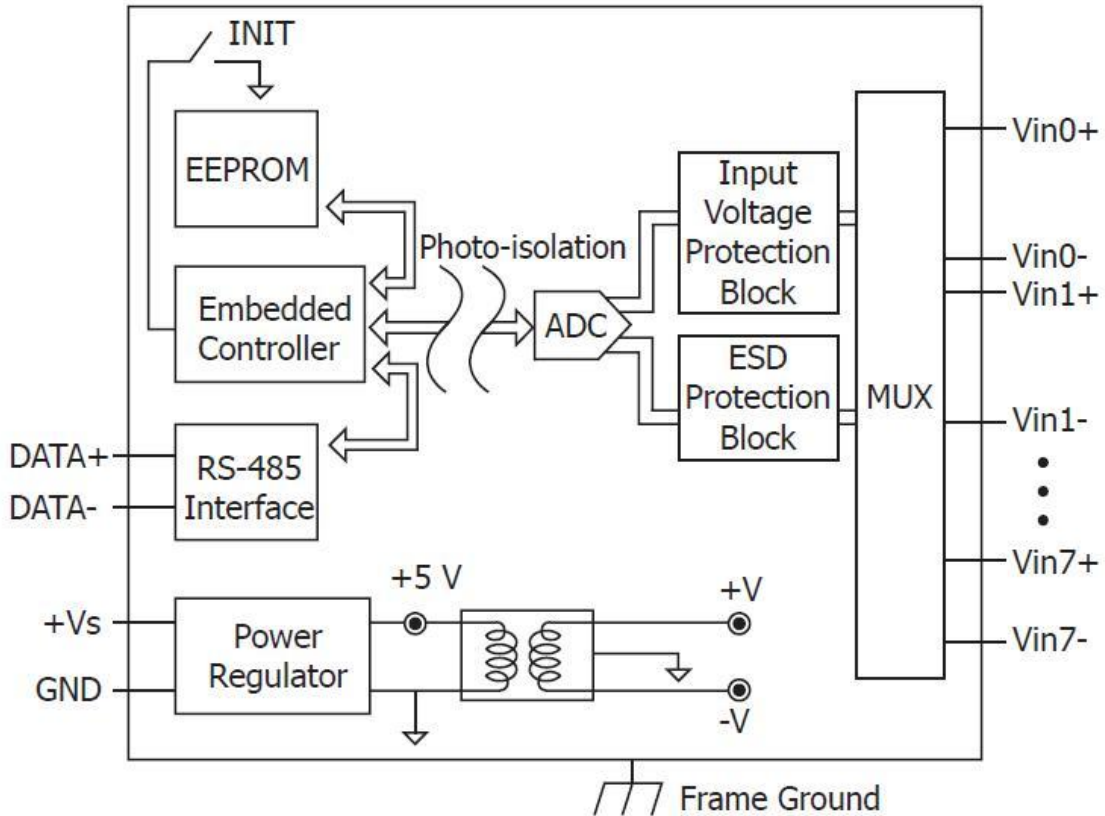

1.4.7 Block diagram for the M-7017mC-16

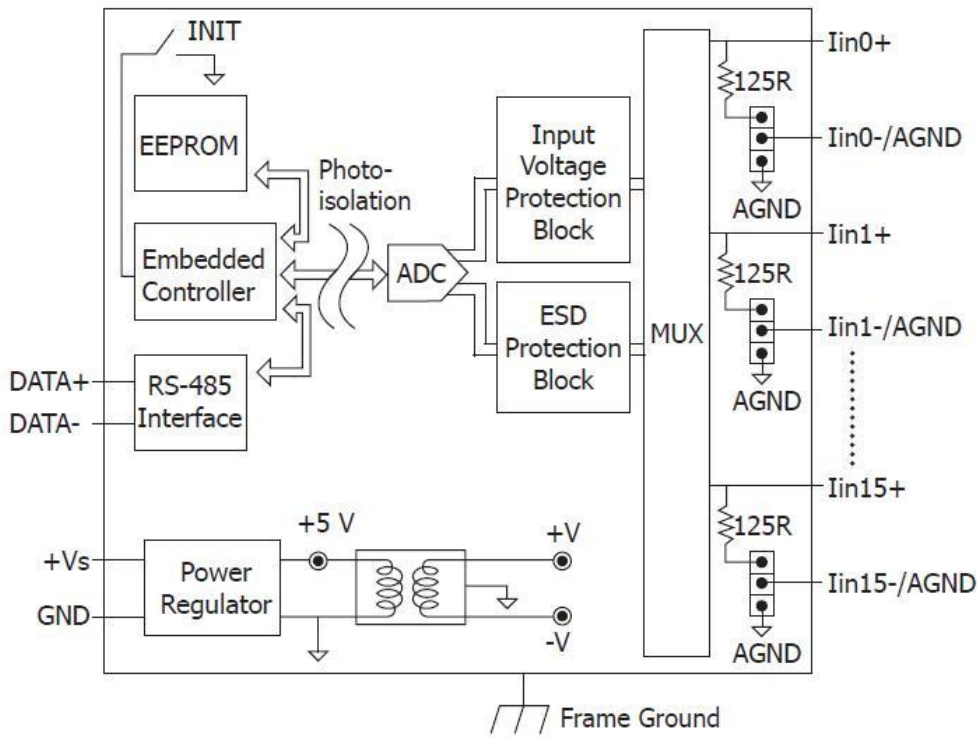

1.4.8 Block diagram for the I-7018, I-7018P and M-7018

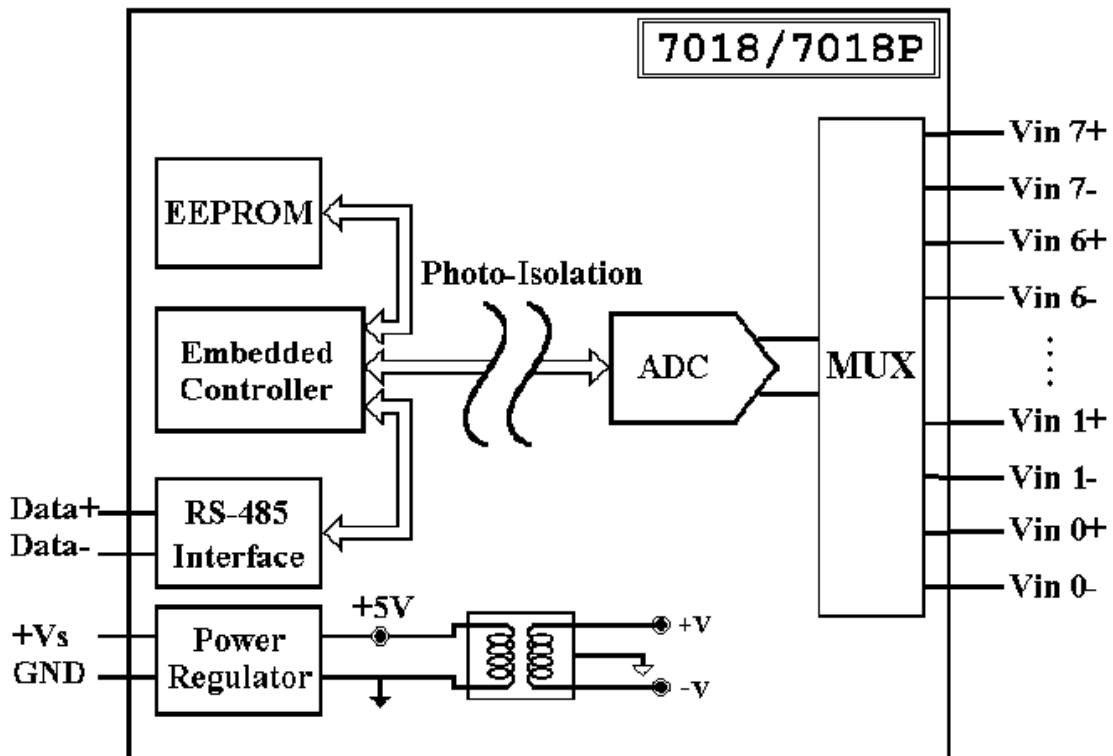

1.4.9 Block diagram for the I-7018BL

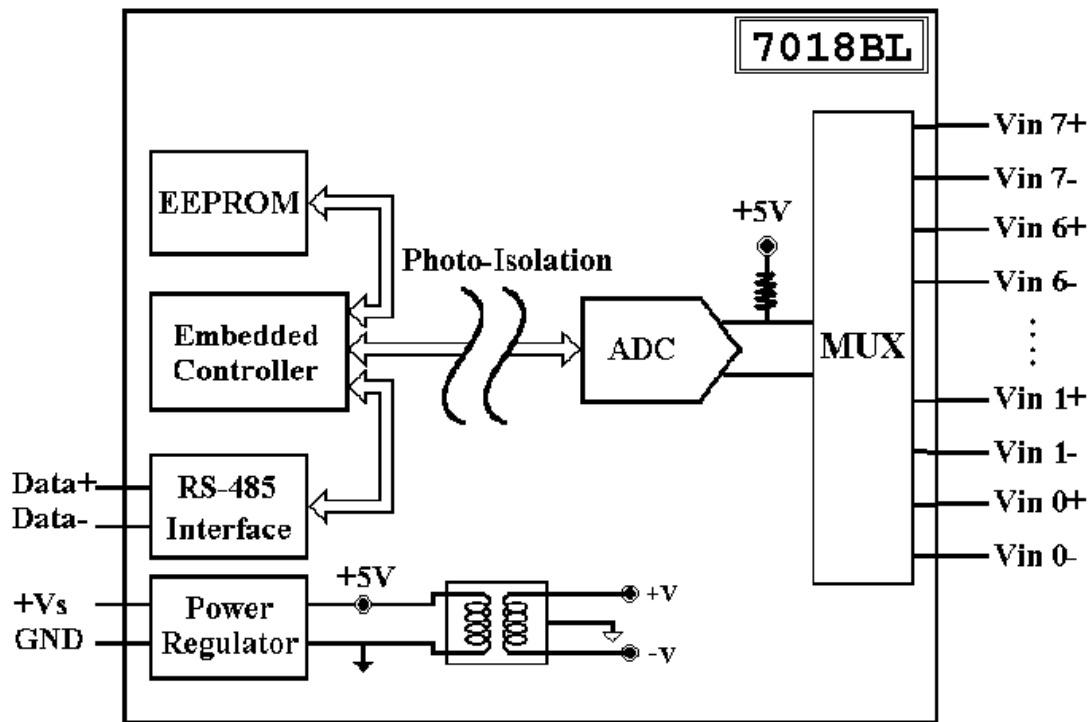

1.4.10 Block diagram for the I-7018R and M-7018R

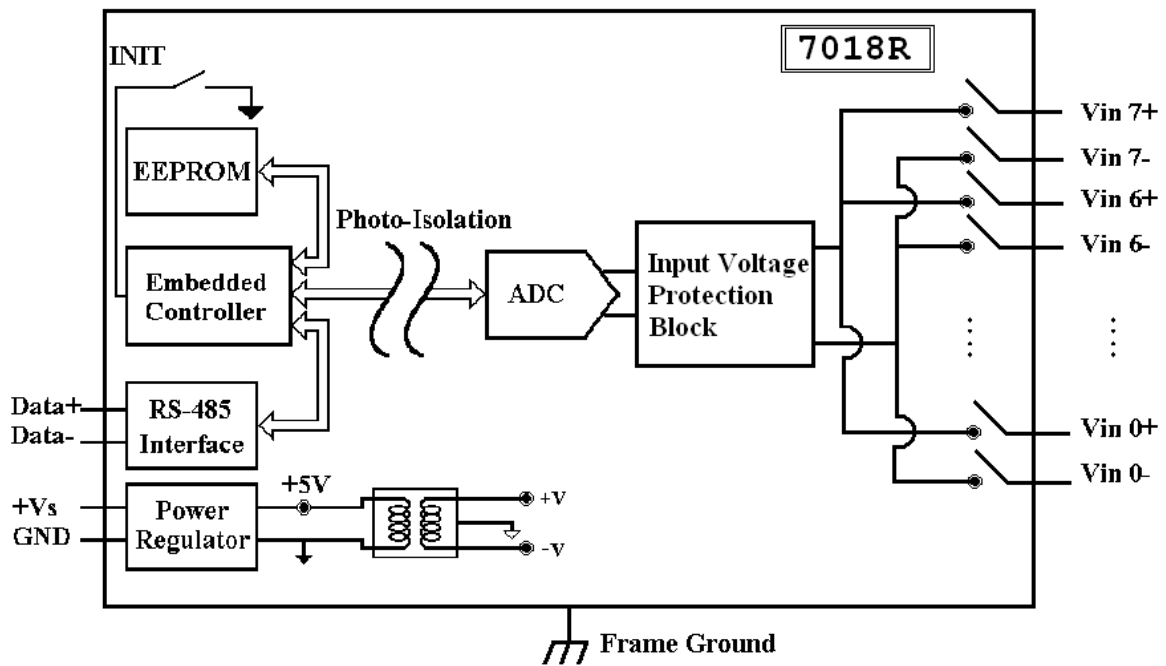

1.4.11 Block diagram for the I-7018Z and M-7018Z

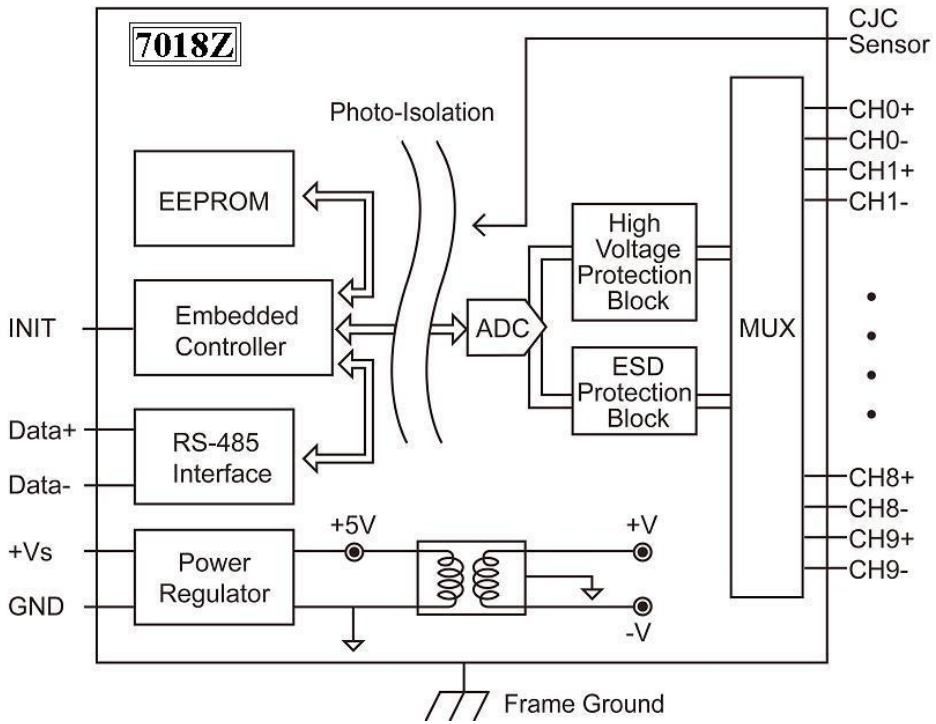

1.4.12 Block diagram for the M-7018-16

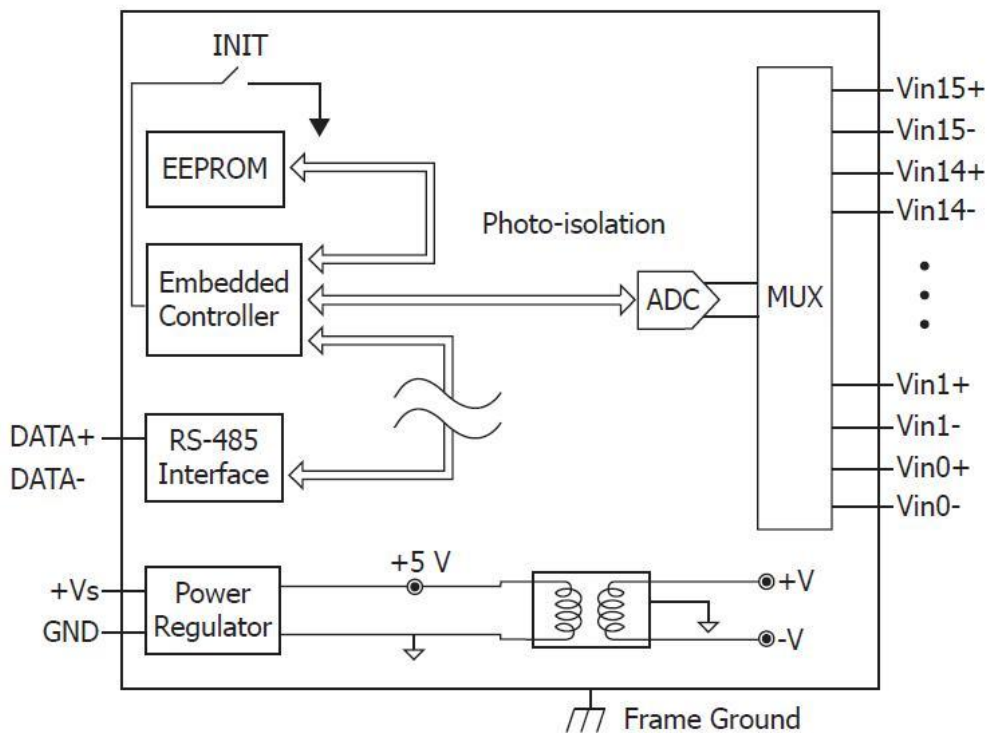

1.4.13 Block diagram for the I-7019R and M-7019R

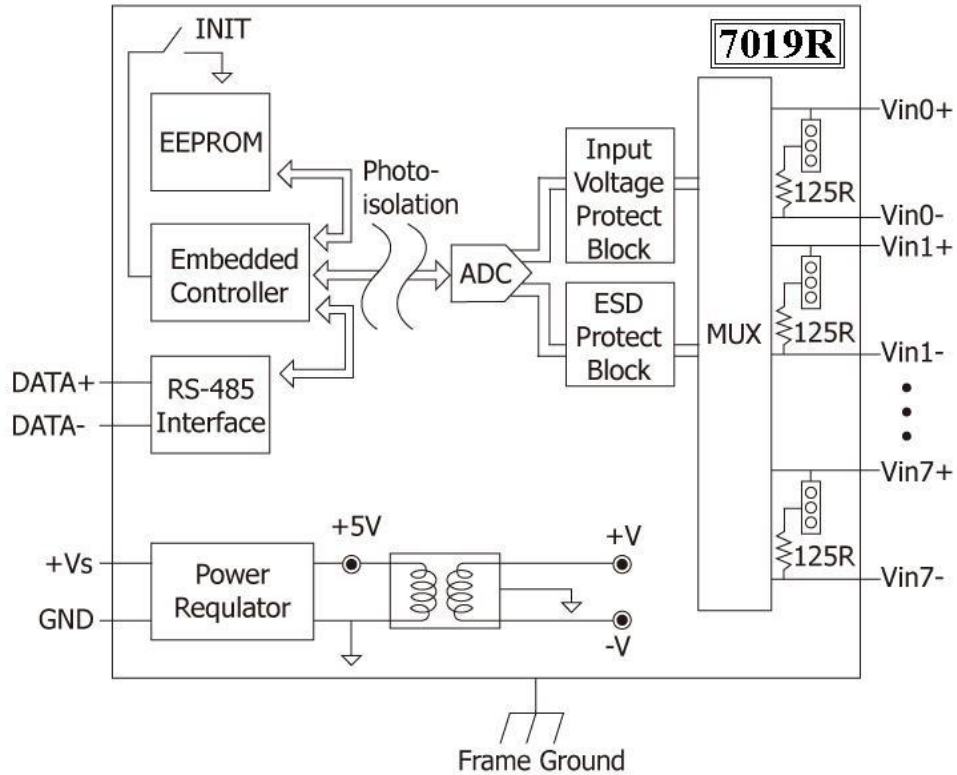

1.4.14 Block diagram for the M-7019Z

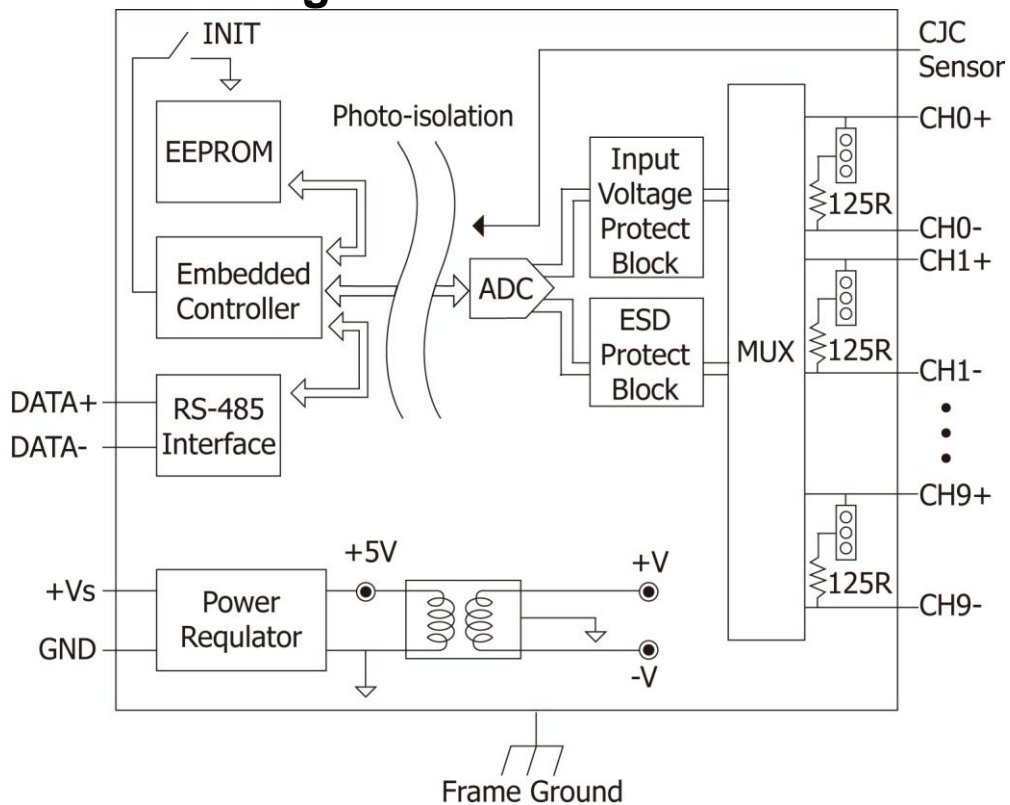

1.5 Dimensions

1.5.1 Modules without Frame Ground

The dimensions of the I-7017, I-7017F, I-7018, I-7018P and I-7018BL are as shown below.

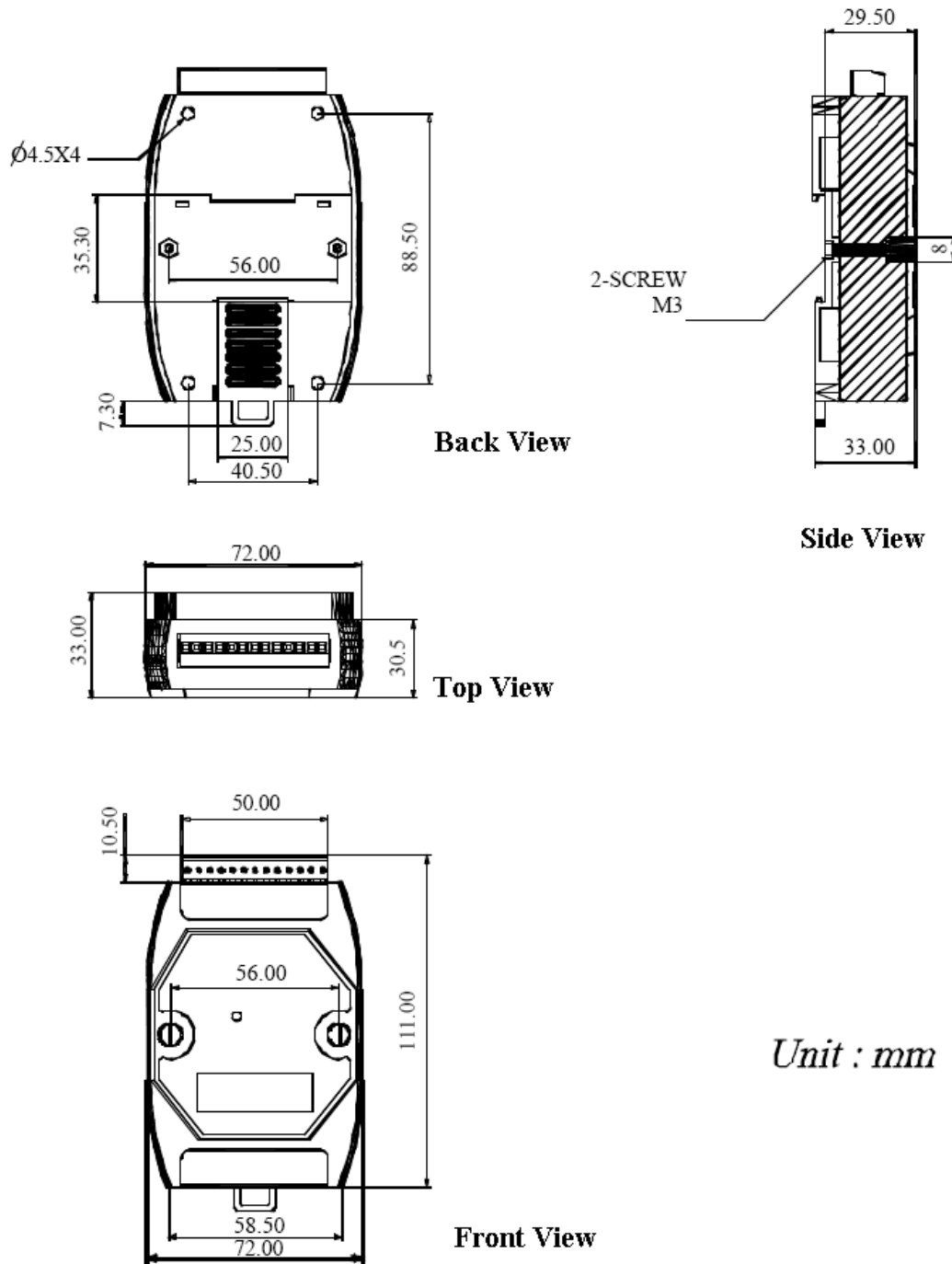

1.5.2 Modules with Frame Ground

The dimensions of the M-7017, I-7017C, I-7017FC, M-7017C, I-7017R, M-7017R, I-7017RC, M-7017RC, I-7017R-A5, M-7017R-A5, I-7017Z, M-7017Z, M-7017RMS, M-7018, I-7018R, M-7018R, I-7018Z, M-7018Z, I-7019R, M-7019R and M-7019Z are as shown below.

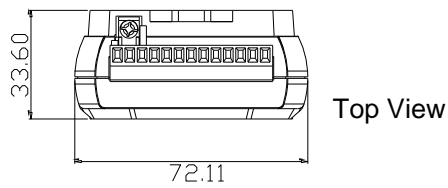
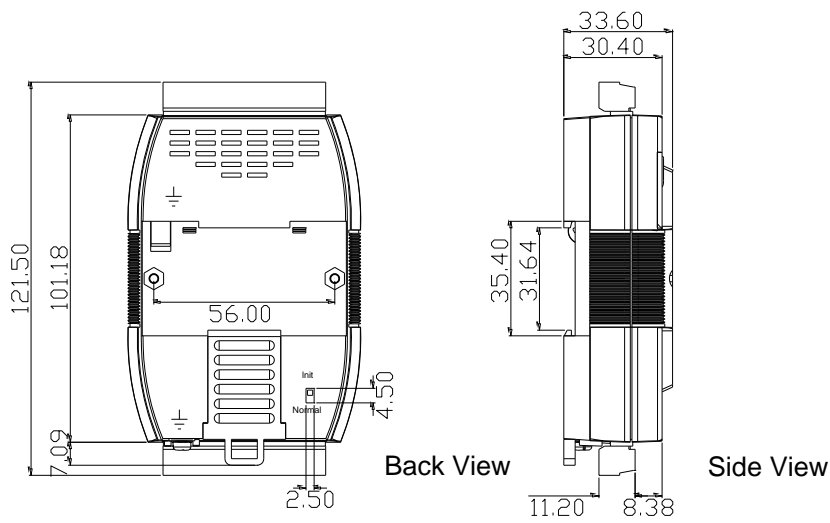

Unit : mm

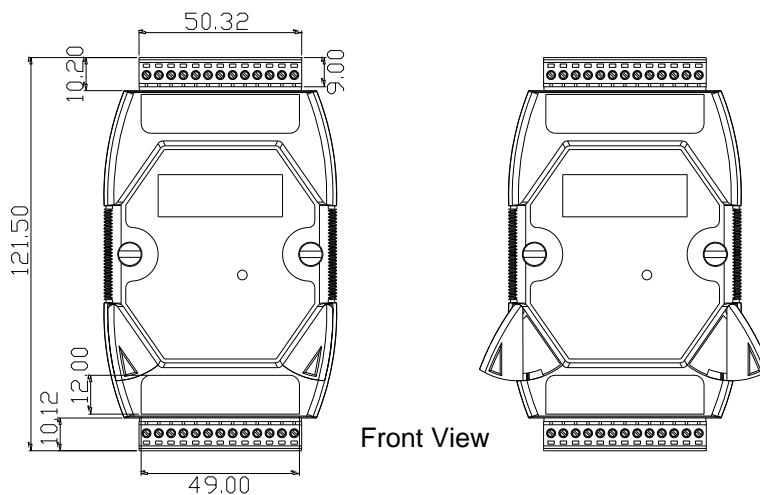

1.5.3 M-7017mC-16 and M-7018-16

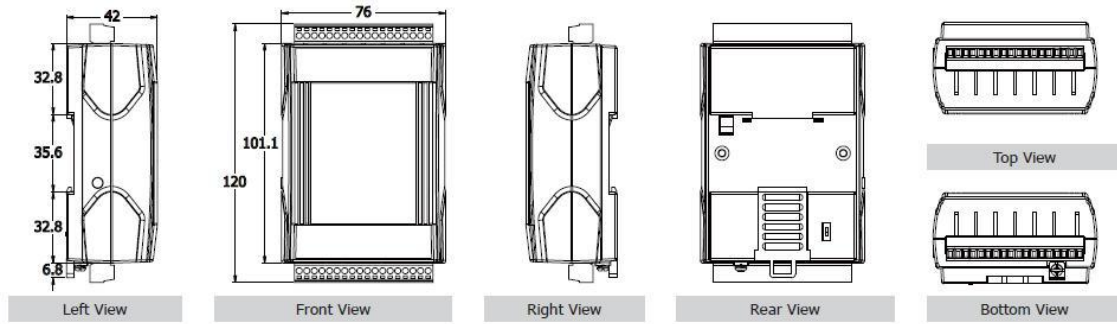

1. 6 Wiring Diagrams

1.6.1 Wiring diagram for the I-7017, I-7017F, I-7017R, M-7017 and M-7017R

For I-7017R, M-7017, M-7017R and channels 0 to 5 of I-7017 and I-7017F



For channels 6 and 7 of I-7017 and I-7017F, single-ended mode, INIT mode available (factory default)

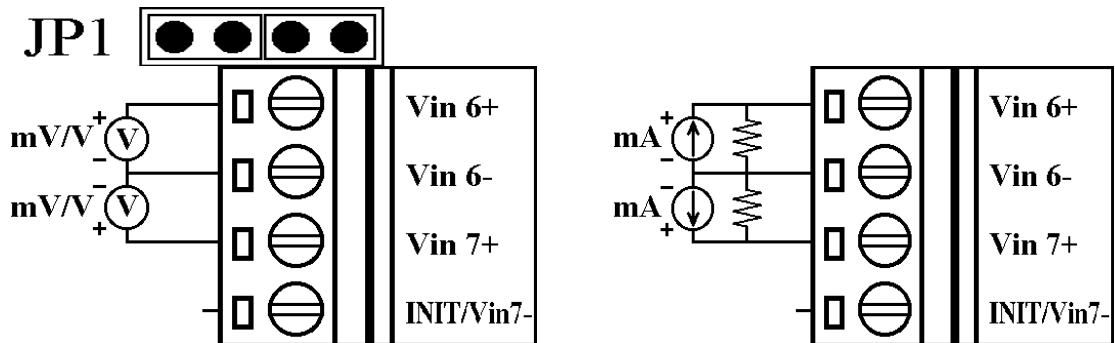

For channels 6 and 7 of I-7017 and I-7017F, differential mode, INIT mode not available

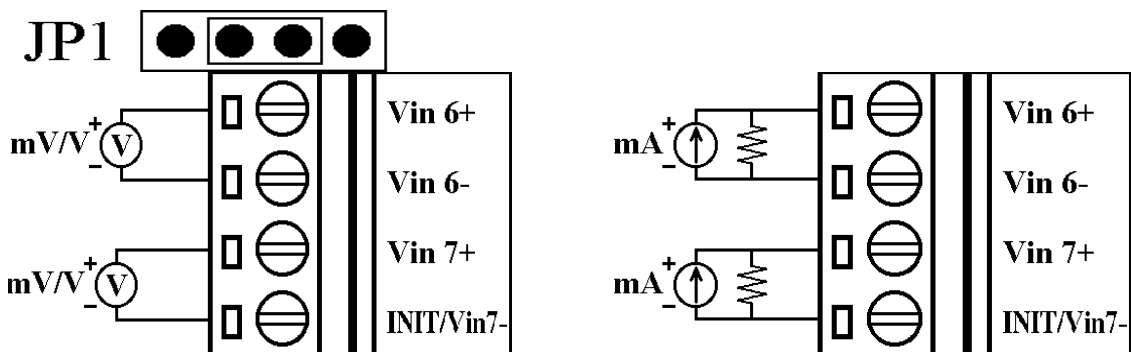

Note: When connecting to a current source, an optional external 125-ohm resistor is required.

1.6.2 Wiring diagram for the I-7017C, I-7017FC, I-7017RC, M-7017C and M-7017RC

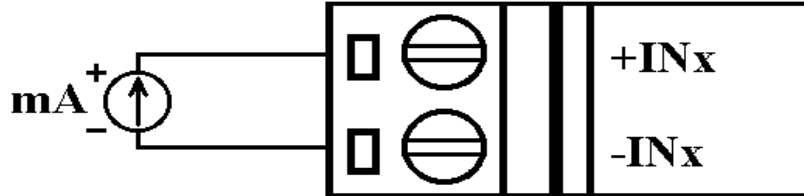

1.6.3 Wiring diagram for the I-7017R-A5 and M-7017R-A5

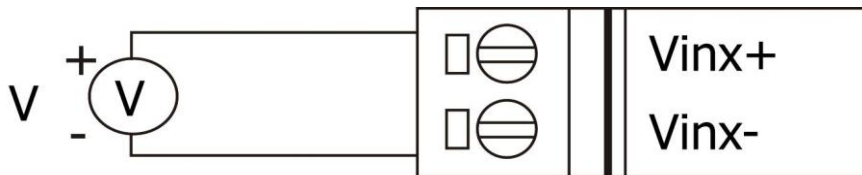

1.6.4 Wiring diagram for the I-7017Z and M-7017Z

| Voltage Input | | |
|-------------------|-------------------|-------------------|
| | Differential Mode | Single-ended Mode |
| JUMPER | | |
| Current Input | | |
| JUMPER | | |

1.6.5 Wiring diagram for the M-7017RMS

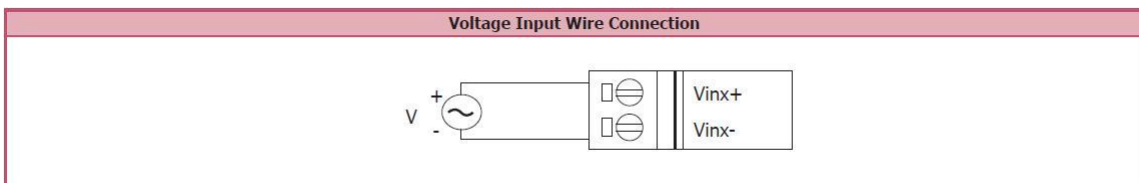

1.6.6 Wiring diagram for the M-7017mC-16

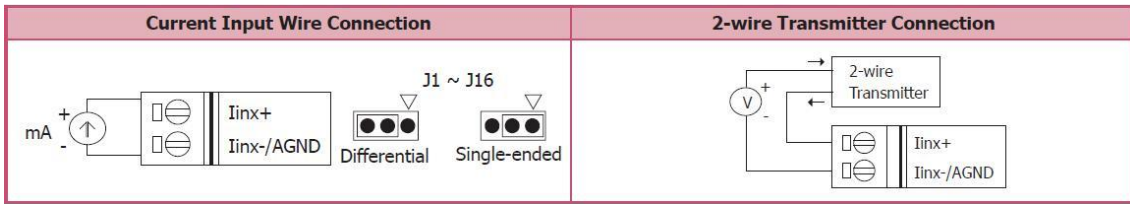

1.6.7 Wiring diagram for the I-7018, I-7018P, I-7018BL, I-7018R, I-7018Z, M-7018, M-7018R and M-7018Z

For I-7018R, I-7018Z, M-7018, M-7018R, M-7018Z and channels 0 to 5 of I-7018, I-7018P and I-7018BL

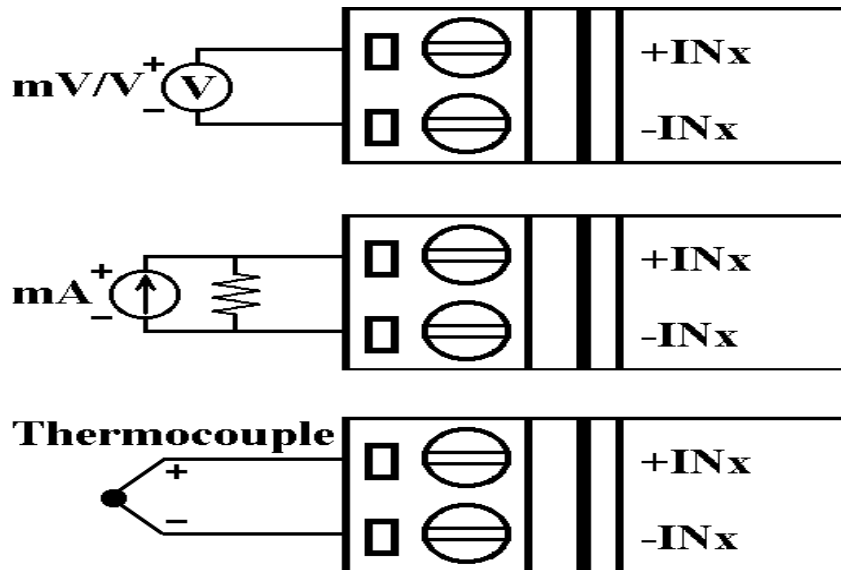

For channels 6 and 7 of I-7018, I-7018P and I-7018BL

Single-ended mode, INIT mode available (factory default)

Differential mode, INIT mode not available

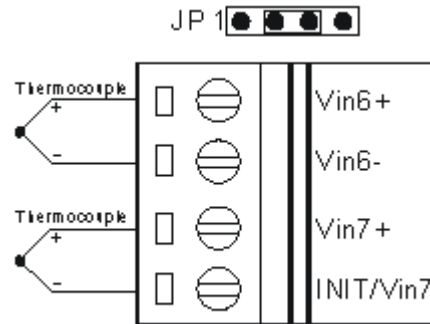
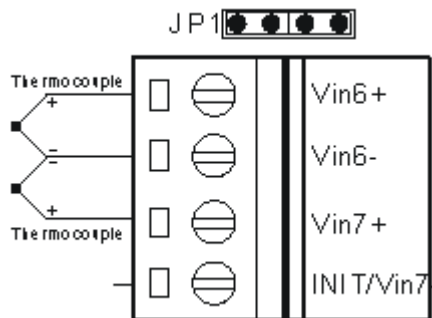

For voltage and current inputs of channels 6 and 7 of I-7018, I-7018P and I-7018BL, the wiring is the same as channels 6 and 7 of I-7017 as shown in Section 1.6.1.

Note: When connecting to a current source, an optional external 125-ohm resistor is required.

1.6.8 Wiring diagram for the M-7018-16

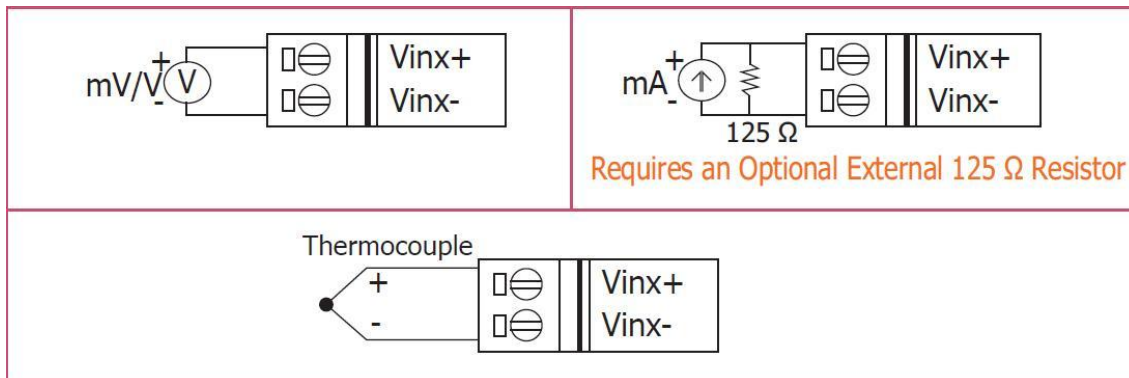

1.6.9 Wiring diagram for the I-7019R, M-7019R and M-7019Z

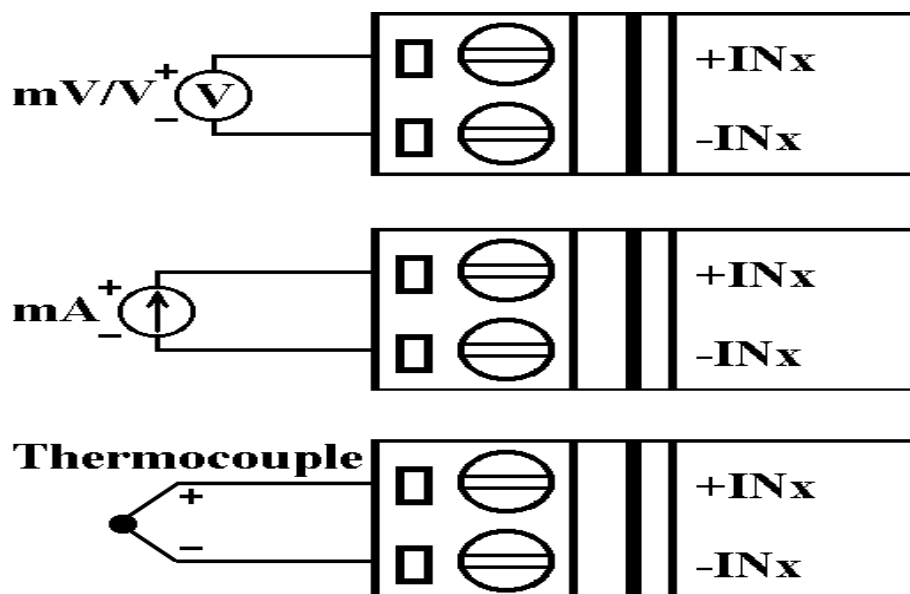

Note: When a channel is connected to a current source, the corresponding jumper should be shorted, see Section 1.7.2 for details.

1.7 Jumper Settings



Note: To access the jumpers, the cover must be opened.

1.7.1 I-7017, I-7017F, I-7018, I-7018P and I-7018BL Jumper Settings

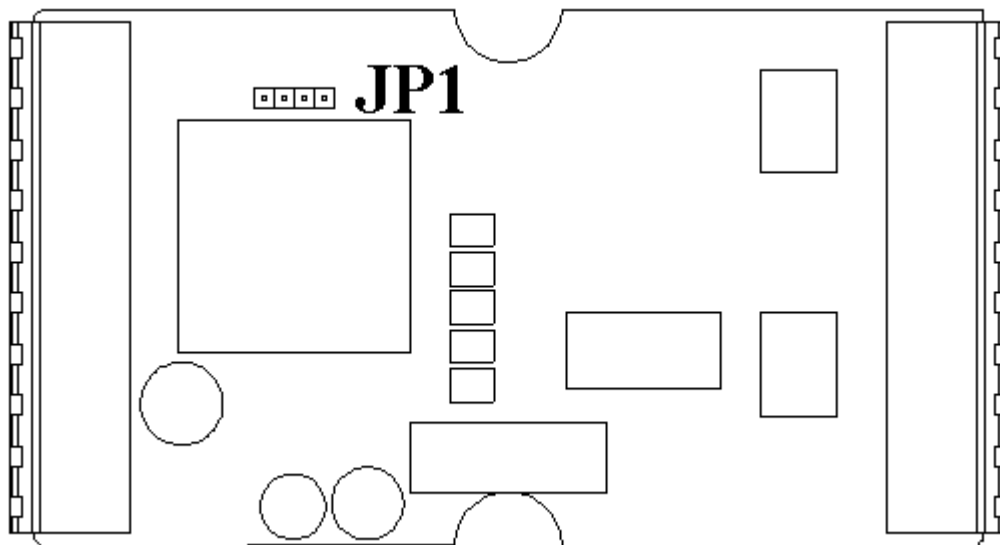
For the I-7017, I-7017F, I-7018, I-7018P and I-7018BL modules, the INIT* terminal is shared with the Vin7-terminal. For I-7017 and I-7017F with PCB version 7.10 and later, please refer to section 1.7.2. For I-7018, I-7018P and I-7018BL with PCB version 4.00 and later, please refer to section 1.7.3. The functionality of the terminal is set using the JP1 jumper. The position of the JP1 jumper is shown in the figure below.



The settings for the JP1 jumper are as follows.

| | |
|--|--|
| JP1  | Terminal INIT*/Vin7- is set to INIT*. Channels 6 and 7 are in single-ended mode and INIT mode is available. (factory default) |
| JP1  | Terminal INIT*/Vin7- is set to Vin7-. Channels 6 and 7 are in differential mode and INIT mode is not available. |

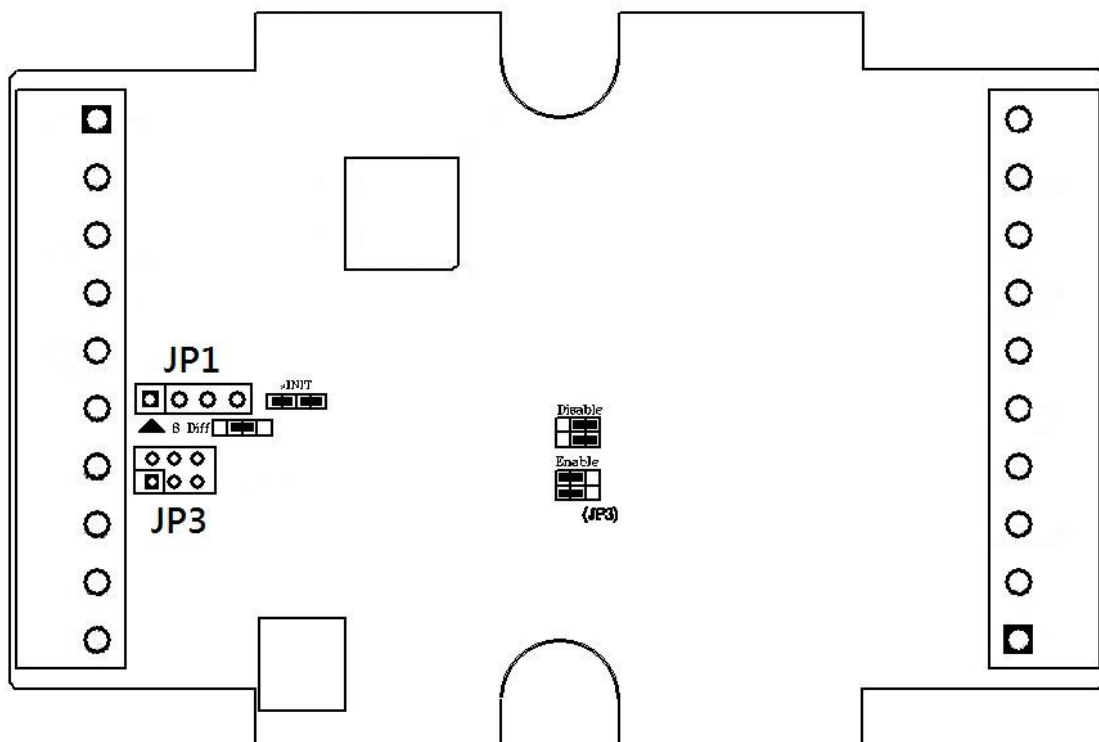

1.7.2 I-7017, I-7017F, I-7017C, I-7017FC, M-7017 and M-7017C Jumper Settings

For the I-7017, I-7017F, I-7017C, I-7017FC, M-7017 and M-7017C modules with PCB version 7.10 and later, there are JP1 and JP3 jumpers as shown in the figure below.



For these modules, the INIT* terminal is shared with the Vin7- terminal. The functionality of the terminal is set

using the JP1 jumper. The settings for the JP1 jumper are as follows.

| | |
|--|---|
| <p>JP1 </p> | <p>Terminal INIT*/Vin7- is set to INIT*. Channels 6 and 7 are in single-ended mode and INIT mode is available. (factory default)</p> |
| <p>JP1 </p> | <p>Terminal INIT*/Vin7- is set to Vin7-. Channels 6 and 7 are in differential mode and INIT mode is not available.</p> |

The JP3 jumper is used to disable/enable the RS-485 bias and the settings for the JP3 jumper are as follows.

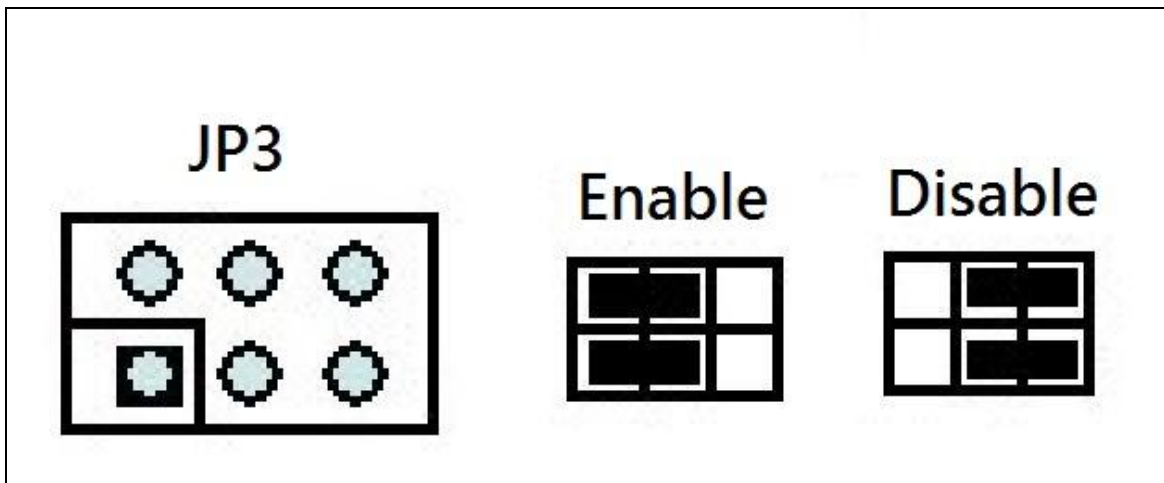

1.7.3 I-7017R, I-7017RC, M-7017R, M-7017RC, I-7018R and M-7018R Jumper Settings

For the I-7017R, I-7017RC, M-7017R, M-7017RC, I-7018R and M-7018R modules with PCB version 5.20 and later, there is JP3 jumper as shown in the figure below.

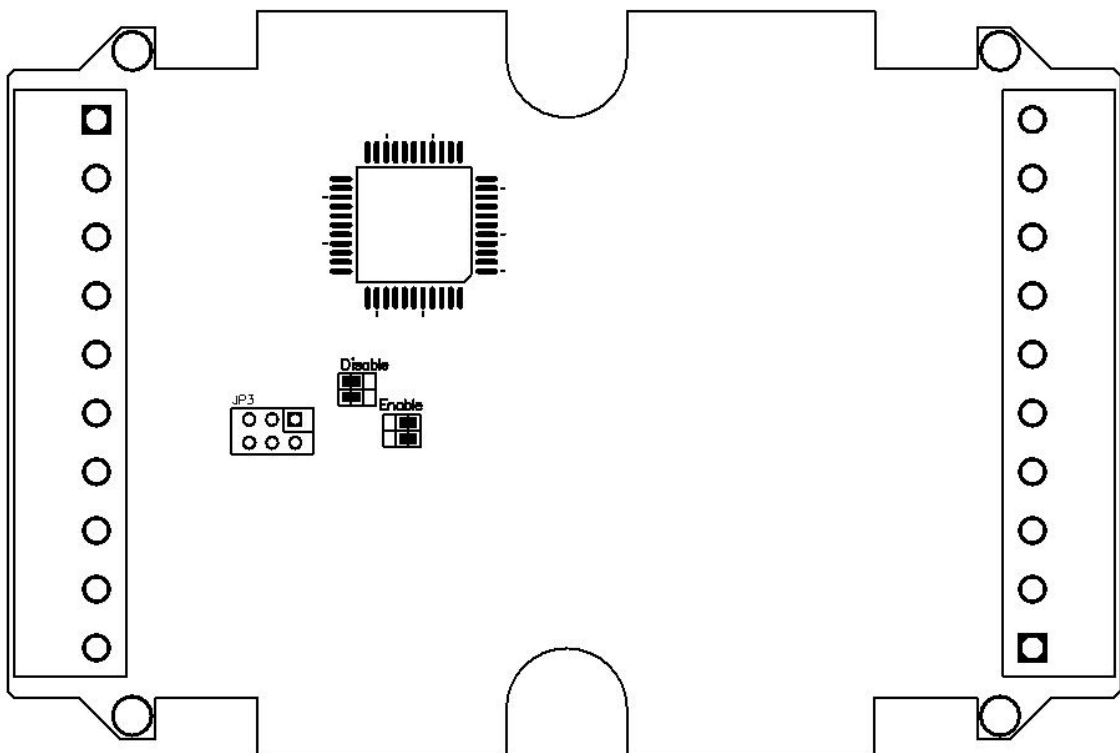

The JP3 jumper is used to disable/enable the RS-485 bias and the settings for the JP3 jumper are as follows.

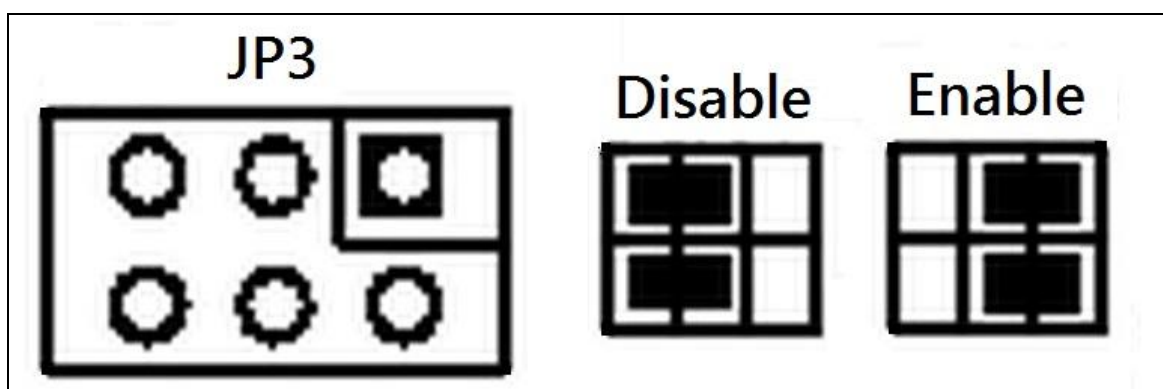

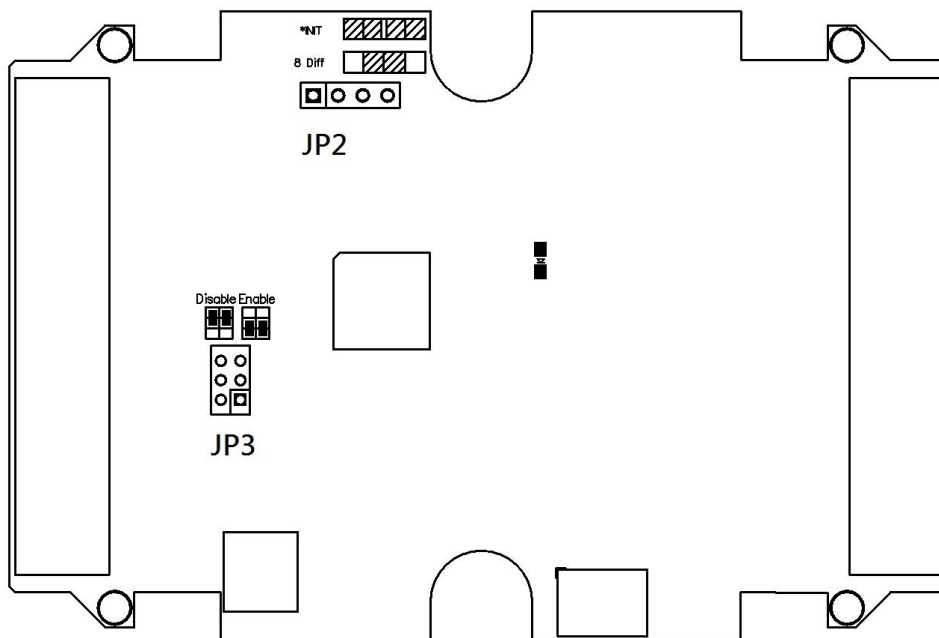

1.7.4 I-7018, I-7018P, I-7018BL and M-7018 Jumper Settings

For the I-7018, I-7018P, I-7018BL and M-7018 modules with PCB version 4.00 and later, the JP2 jumper is shown in the figure below. For the I-7018, I-7018P, I-7018BL and M-7018 modules with PCB version 4.30 and later, there is the JP3 jumper as shown in the following figure.



For these modules, the INIT* terminal is shared with the Vin7- terminal. The functionality of the terminal is set using the JP2 jumper. The settings for the JP2 jumper are as follows.

| | |
|--|---|
| <p>JP2 </p> | <p>Terminal INIT*/Vin7- is set to INIT*. Channels 6 and 7 are in single-ended mode and INIT mode is available. (factory default)</p> |
| <p>JP2 </p> | <p>Terminal INIT*/Vin7- is set to Vin7-. Channels 6 and 7 are in differential mode and INIT mode is not available.</p> |

The JP3 jumper is used to disable/enable the RS-485 bias and the settings for the JP3 jumper are as follows.

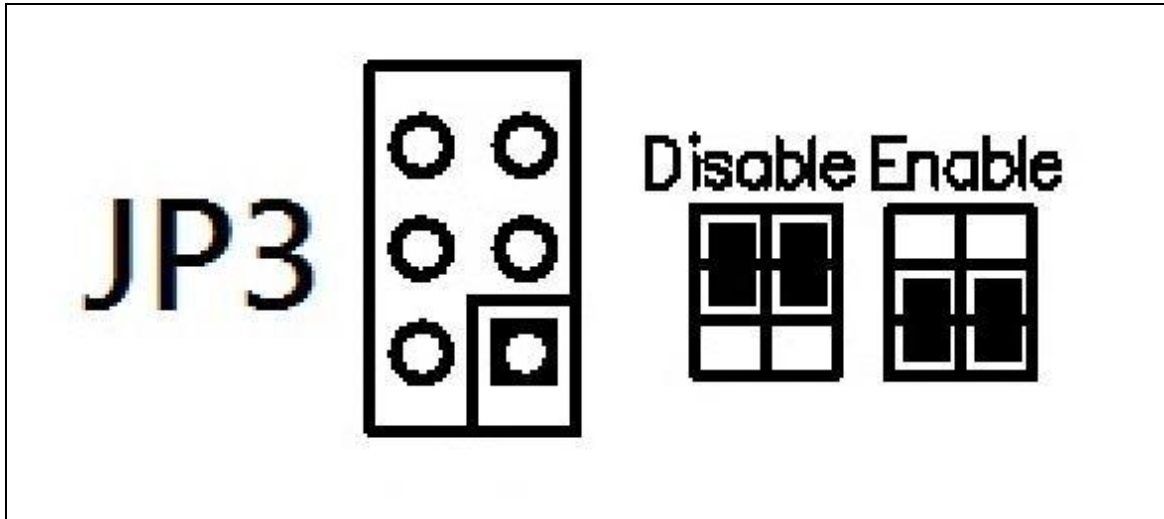

1.7.5 I-7019R and M-7019R Jumper Settings

The I-7019R and M-7019R modules can accept current inputs from -20mA to 20mA . No external resistor required but the corresponding jumper must be shorted. The following figure shows the jumper positions.

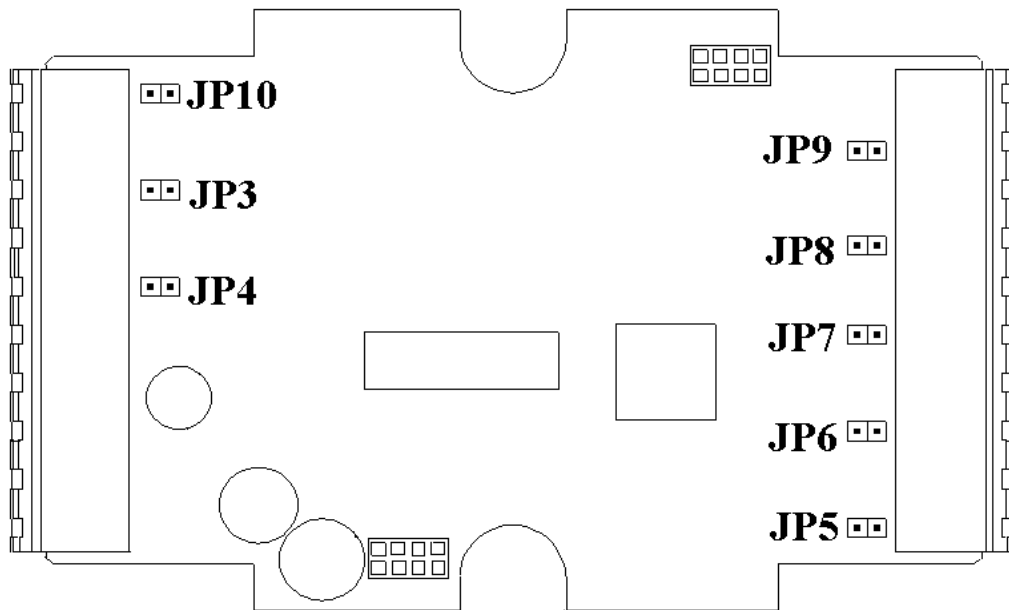

The corresponding jumpers and channels are as follows.

| | | | | | | | | |
|---------|-----|-----|-----|-----|-----|------|-----|-----|
| Channel | 0 | 1 | 2 | 3 | 4 | 5 | 6 | 7 |
| Jumper | JP5 | JP6 | JP7 | JP8 | JP9 | JP10 | JP3 | JP4 |

When a channel is connected to a current input, the corresponding jumper should be shorted. For example, to connect a current input to channel 3, short the JP8 jumper.

For I-7019R and M-7019R PCB version 4.4 and later, the jumpers for current input are shown in the following figure.

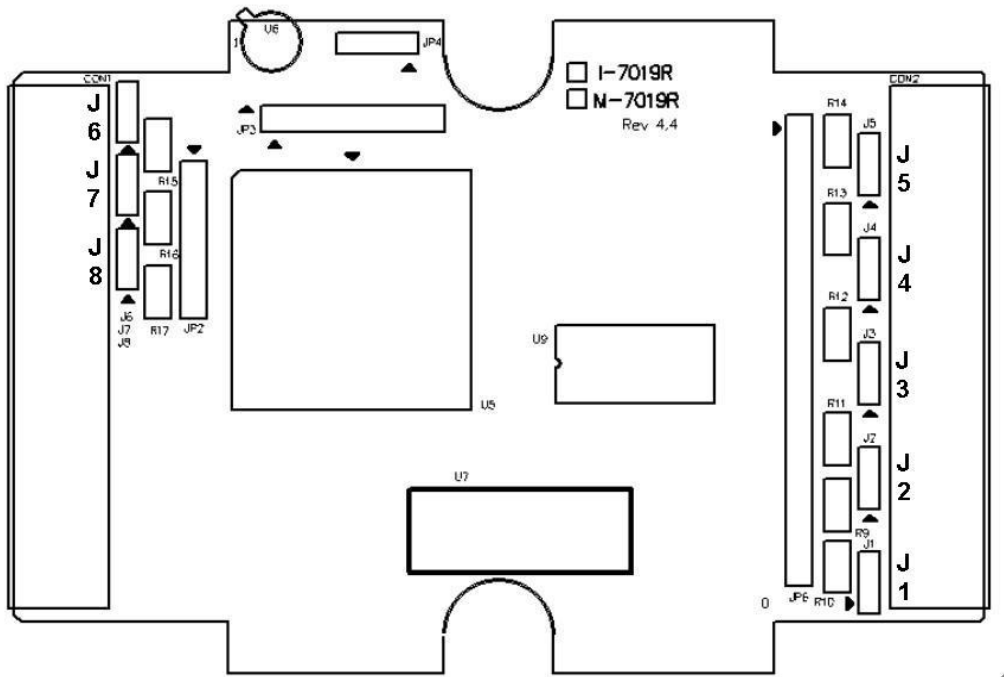

The corresponding jumpers and channels are as follows.

| | | | | | | | | |
|---------|----|----|----|----|----|----|----|----|
| Channel | 0 | 1 | 2 | 3 | 4 | 5 | 6 | 7 |
| Jumper | J1 | J2 | J3 | J4 | J5 | J6 | J7 | J8 |

The jumper position for voltage and current inputs are:

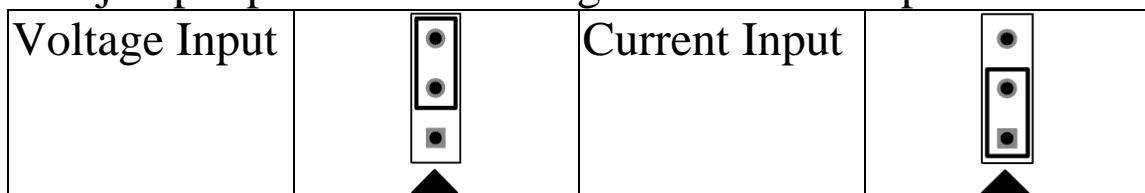

For I-7019R and M-7019R PCB version 5.21 and later, there is jumper to enable the RS-485 bias as shown in the following figure.

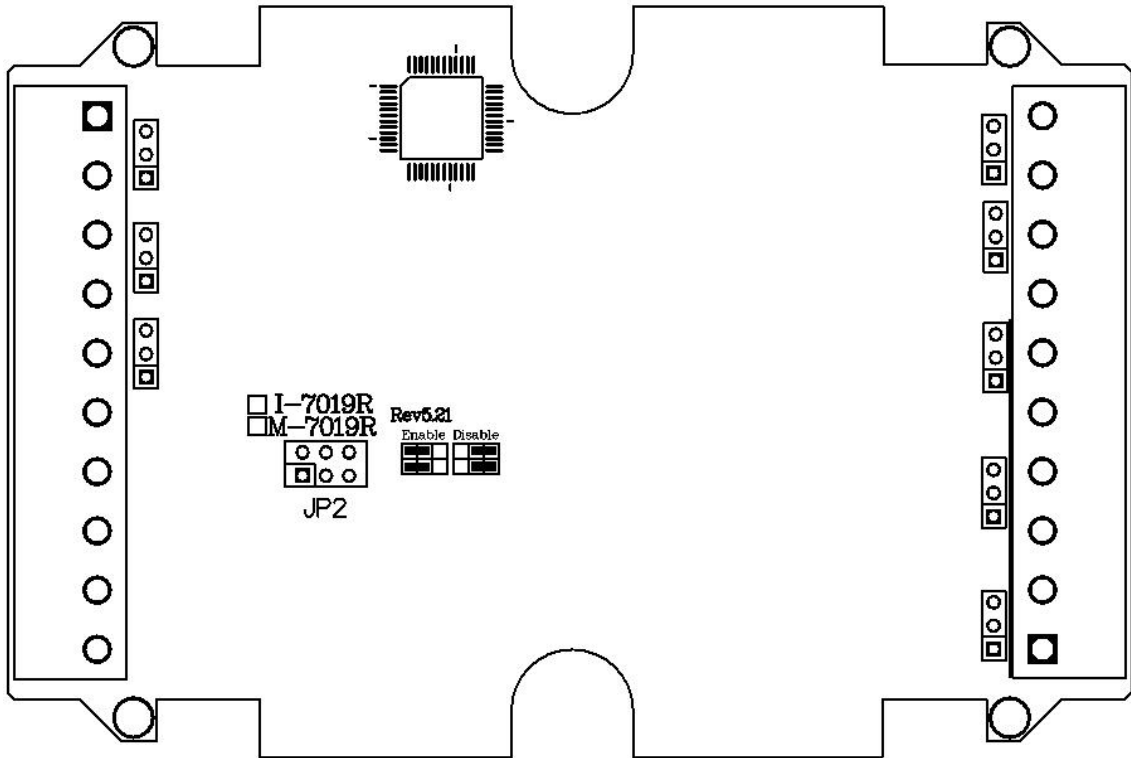

The JP2 jumper is used to disable/enable the RS-485 bias and the settings for the JP2 jumper are as follows.

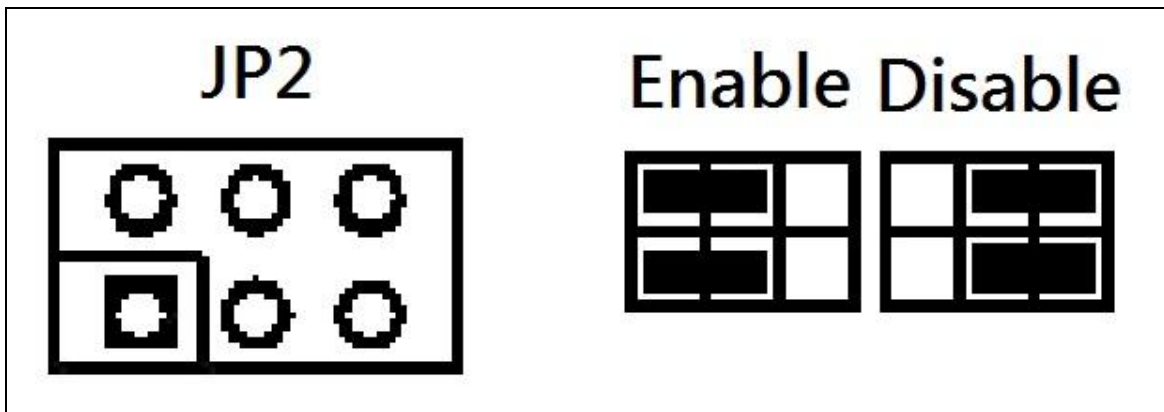

1.7.6 M-7019Z Jumper Settings

The M-7019Z can accept current inputs from -20mA to 20mA . No external resistor required but the corresponding jumper must be shorted. The following figure shows the jumper positions.

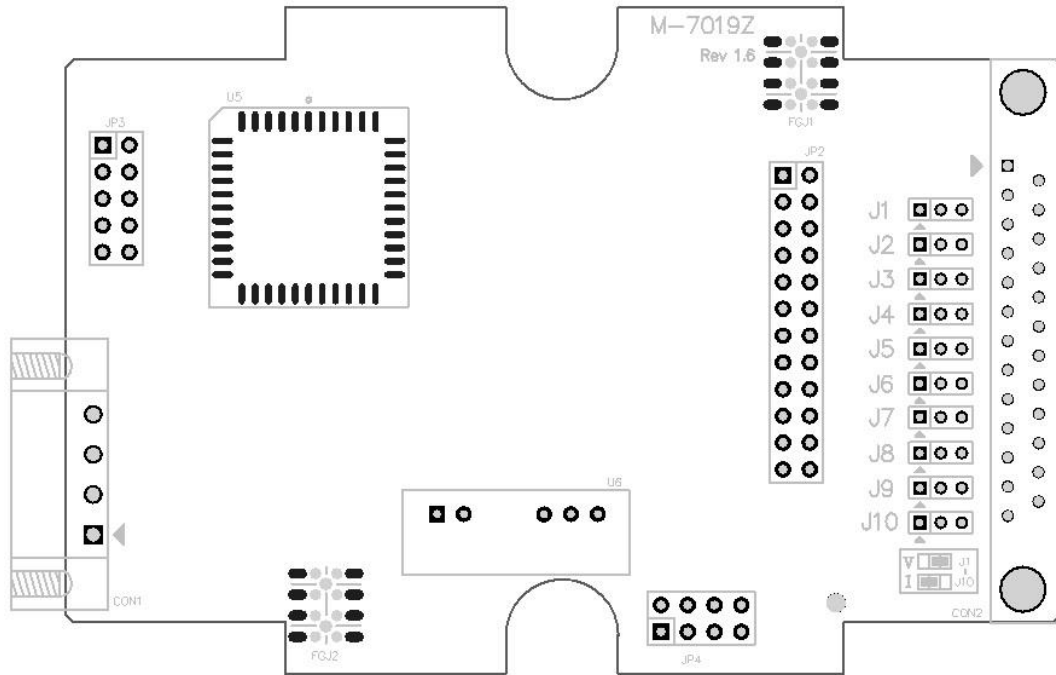

The corresponding jumpers and channels are as follows.

| | | | | | | | | | | |
|---------|----|----|----|----|----|----|----|----|----|-----|
| Channel | 0 | 1 | 2 | 3 | 4 | 5 | 6 | 7 | 8 | 9 |
| Jumper | J1 | J2 | J3 | J4 | J5 | J6 | J7 | J8 | J9 | J10 |

The jumper position for voltage and current inputs are:

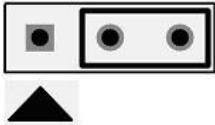
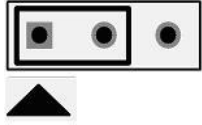
| | | | |
|---------------|---|---------------|---|
| Voltage Input |  | Current Input |  |
|---------------|---|---------------|---|

1.7.7 I-7017Z and M-7017Z Jumper Settings

The I-7017Z and M-7017Z can accept current inputs from -20mA to 20mA . No external resistor required but the corresponding jumper must be shorted. The following figure shows the jumper positions.

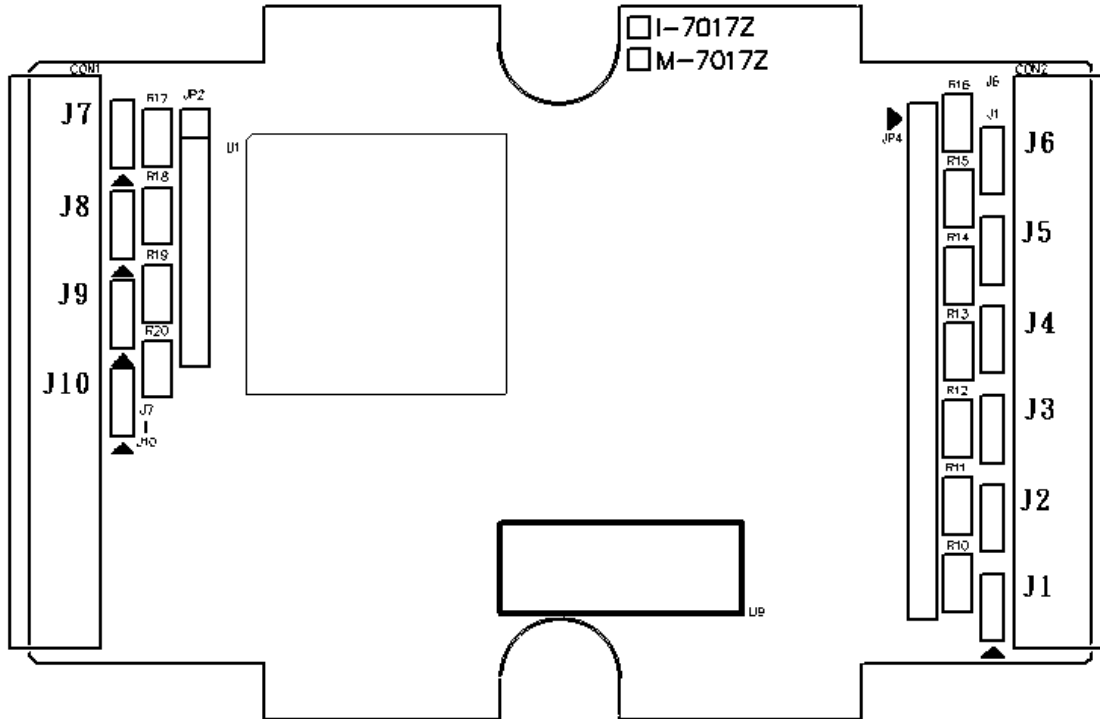

The corresponding jumpers and channels are as follows.

| | | | | | | | | | | |
|---------|----|----|----|----|----|----|----|----|----|-----|
| Channel | 0 | 1 | 2 | 3 | 4 | 5 | 6 | 7 | 8 | 9 |
| Jumper | J1 | J2 | J3 | J4 | J5 | J6 | J7 | J8 | J9 | J10 |

The jumper position for voltage and current inputs are:

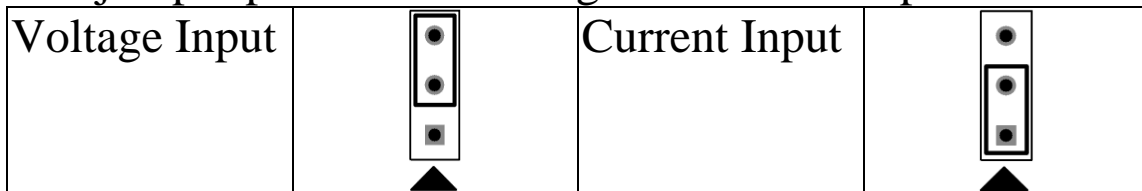

For I-7017Z and M-7017Z PCB version 3.00 and later, there is jumper to enable the RS-485 bias as shown in the following figure.

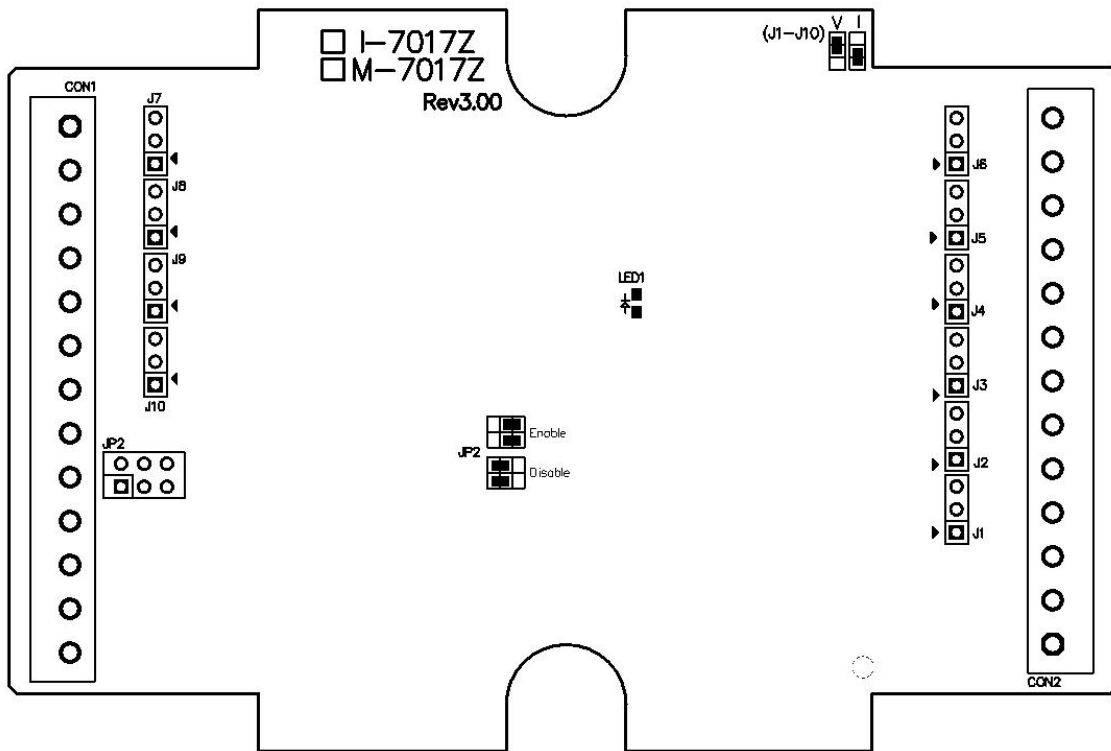

The JP2 jumper is used to disable/enable the RS-485 bias and the settings for the JP2 jumper are as follows.

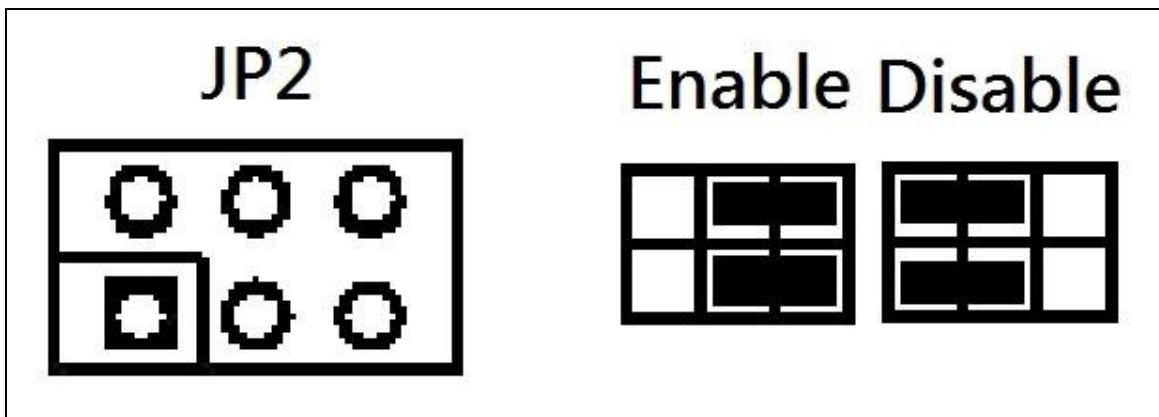

1.7.8 M-7017mC-16 Jumper Settings

The current inputs of the M-7017mC-16 can be differential or single-ended that are selected by jumpers J1 to J16. The following figure shows the jumper positions.

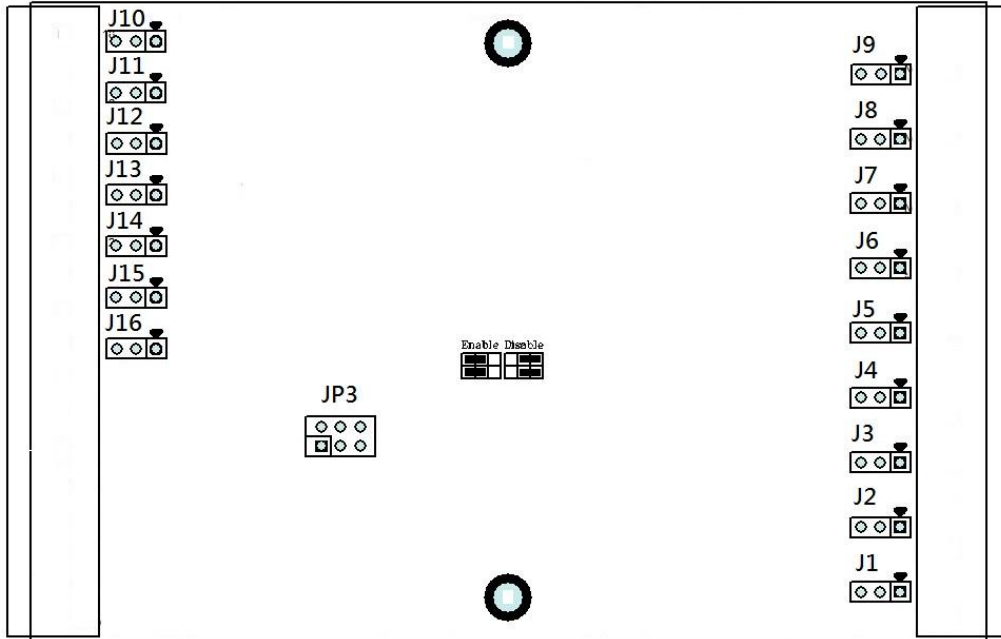

The corresponding jumpers and channels are as follows.

| | | | | | | | | |
|---------|----|-----|-----|-----|-----|-----|-----|-----|
| Channel | 0 | 1 | 2 | 3 | 4 | 5 | 6 | 7 |
| Jumper | J1 | J2 | J3 | J4 | J5 | J6 | J7 | J8 |
| Channel | 8 | 9 | 10 | 11 | 12 | 13 | 14 | 15 |
| Jumper | J9 | J10 | J11 | J12 | J13 | J14 | J15 | J16 |

The jumper position for differential or single-ended inputs are:

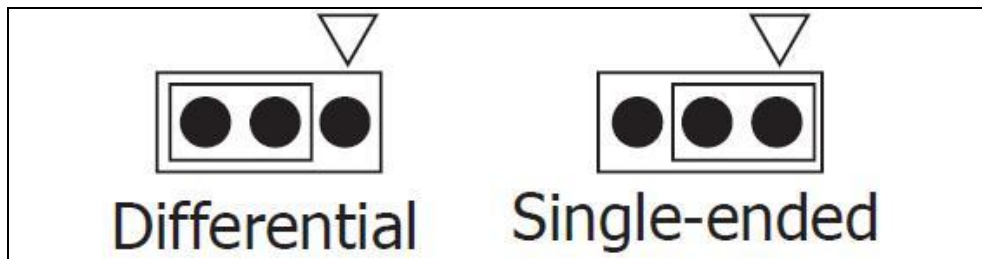

The JP3 jumper is used to disable/enable the RS-485 bias and the settings for the JP3 jumper are as follows.

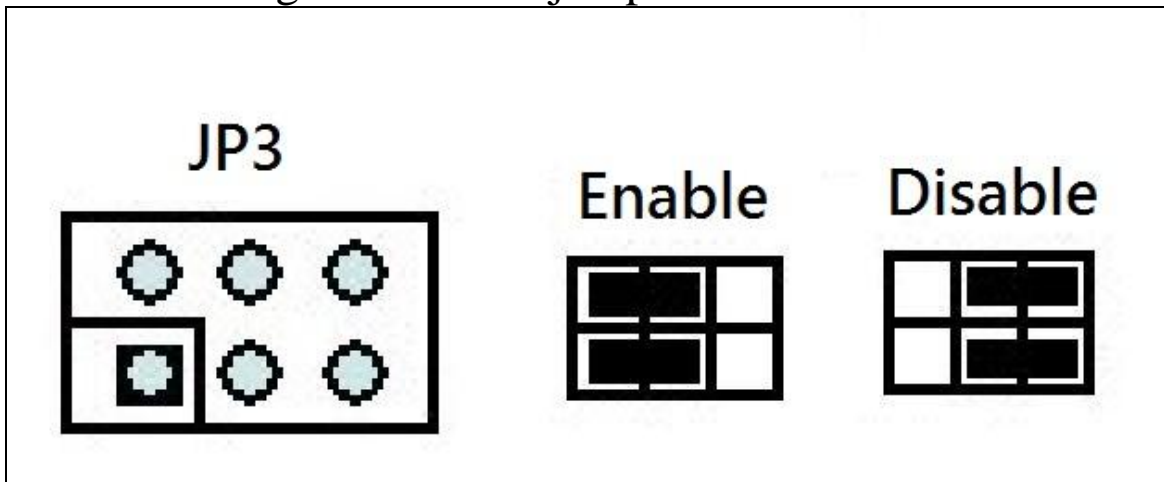

1.7.9 M-7018-16 Jumper Settings

For M-7018-16 PCB version 1.10 and later, there is jumper to enable the RS-485 bias as shown in the following figure.

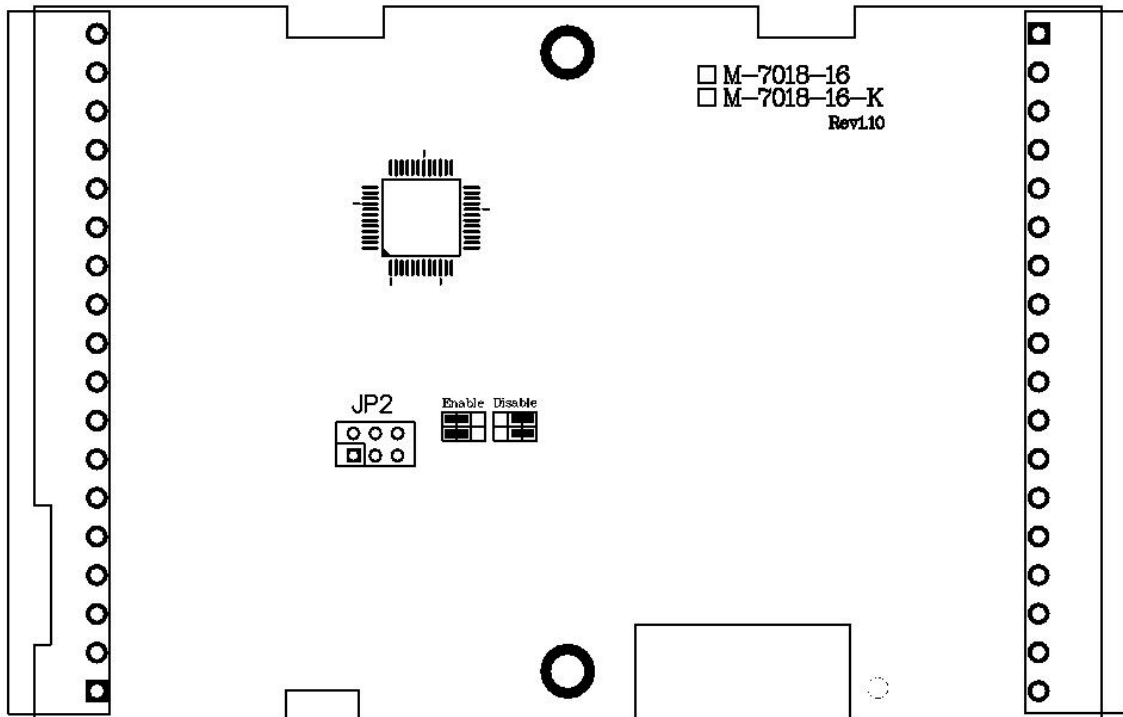

The JP2 jumper is used to disable/enable the RS-485 bias and the settings for the JP2 jumper are as follows.

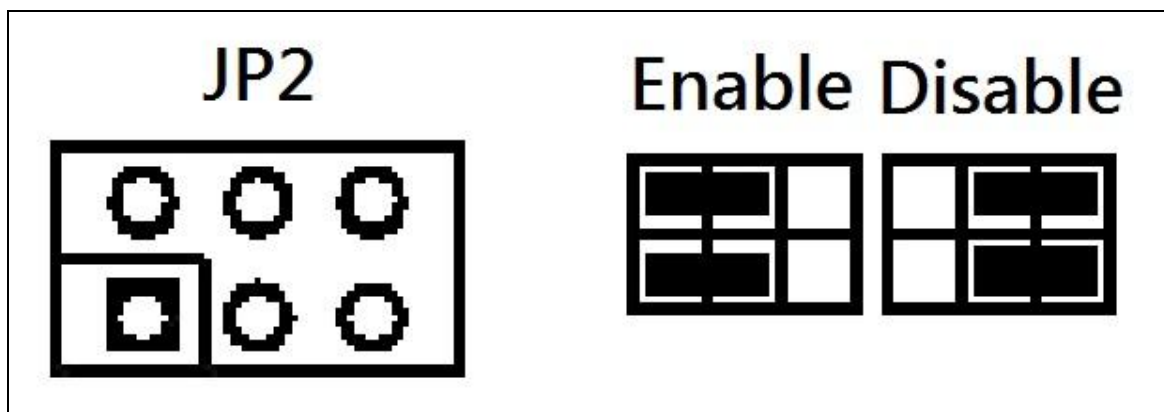

1.8 Quick Start

To install the module, follow the steps below:

1. Connect the analog input. See Section 1.2 for the terminal assignment and Section 1.6 for the wiring diagram.
2. Connect the module to the RS-485 network using the DATA+ and DATA- terminals. See Section 1.2 for the terminal assignment. If the host is only equipped with an RS-232 interface, then an RS-232 to RS-485 converter will be required. Refer to the “**I-7000 Bus Converter User’s Manual**” for more information.
3. Connect the module to the power supply using the +Vs and GND terminals. See Section 1.2 for the terminal assignment. Note that the voltage supplied should be in the range of +10 to +30V DC.
4. For I-7000 modules, configure the module by sending the %AANNTTCCFF command. See Section 2.1 for details. To configure the I-7017Z, I-7018Z and I-7019 series, the \$AA7CiRrr command must also be sent. See Section 2.15 for details. For M-7000 modules using the Modbus RTU protocol, configure the module using the following functions.
 - Sub-function 04h of Function 46h, see Section 3.3.2
 - Sub-function 06h of Function 46h, see Section 3.3.4
 - Sub-function 08h of Function 46h, see Section 3.3.6The default settings for the module can be found in Section 1.9.
5. For I-7000 modules, in order to read data from the input channels, send either the #AA or #AAN command to the module. See Sections 2.3 and 2.4 for details. For M-7000 modules using the Modbus RTU

protocol, use Function 04h to read the data from the input channels. See Section 3.2 for details.

6. If the host is a PC with a Windows operating system installed, the DCON Utility can be used to allow easy configuration and reading of data. The DCON Utility can be downloaded from the ICP DAS website (<http://www.icpdas.com>). The documentation for the DCON Utility can be found in the "**Getting Started For I-7000 Series Modules**" manual.

Refer to the "**I-7000 Bus Converter User's Manual**" and "**Getting Started For I-7000 Series Modules**" manuals for more details. The "**Getting Started For I-7000 Series Modules**" manual can be downloaded from the ICP DAS website (<http://www.icpdas.com>).

1.9 Default Settings

Default settings for the I-7017, I-7018 and I-7019 series modules are:

- Module address: 01
- Analog input type:
 - Type 08, -10V to 10V, for the I-7017 and I-7019 series
 - Type 1B, -150V to +150V for the I-7017R-A5
 - Type 0D, -20mA to +20mA for the I-7017C, I-7017FC and I-7017RC
 - Type 05, -2.5V to 2.5V, for the I-7018 series
- Baud Rate: 9600 bps
- Checksum disabled
- Engineering unit format
- Filter set at 60Hz rejection (Not used by the I-7019R, firmware version B2.6 and earlier)
- Fast mode for I-7017F and I-7017FC
- JP1 set to single-ended mode for the I-7017, I-7017F, I-7018, I-7018P and I-7018BL.

Default settings for the M-7017, M-7018 and M-7019 series modules are:

- Protocol: Modbus RTU
- Module address: 01
- Analog input type:
 - Type 08, -10V to 10V, for the M-7017 and M-7019 series
 - Type 1B, -150V to 150V, for the M-7017R-A5
 - Type 0D, -20mA to +20mA for the M-7017C, M-7017RC and M-7017mC-16
 - Type 05, -2.5V to 2.5V, for the M-7018 series
- Baud Rate: 9600 bps
- Filter set at 60Hz rejection (Not used by the M-7019R, firmware version B2.6 and earlier)

1.10 Calibration

Warning: *It is not recommended that calibration be performed until the process is fully understood.*

The calibration procedure is as follows:

1. Warm up the module for 30 minutes.
2. Set the type code to the type you want to calibrate. Refer to Sections 2.1 and 2.15 for details.
3. Enable calibration. Refer to Section 2.31 for details.
4. Apply the zero calibration voltage/current.
5. Send the zero calibration command. Refer to Sections 2.6 and 2.8 for details.
6. Apply the span calibration voltage/current.
7. Send the span calibration command. Refer to Sections 2.5, 2.7 and 2.9 for details.
8. Repeat steps 3 to 7 three times.

Notes:

1. For the I-7017 and I-7018 series, connect the calibration voltage/current to channel 0.
2. When calibrating type 06 for the I-7018 series and type 0D for the I-7017 series, a resistor of 125 ohms, 0.1% should be connected, not required for I-7017C, I-7017FC, I-7017RC, and I-7017Z. Refer to Section 1.6 for details.
3. When calibrating type 0D for the I-7017Z, the jumper of channel 0 should be set to the current input position.
4. For the I-7019 series, each channel should be calibrated separately. When calibrating type 06, the jumper of the corresponding channel should be short. Refer to Section 1.7.2 for details.

5. For the M-7017mC-16, repeat steps 6 and 7 for channel 1 to 15.
6. Calibration voltages and currents are shown below.
7. The M-7000 series modules must be switched to the DCON protocol mode before calibrating. Refer to Section 3.3.4 for details of the switching protocol.

Calibration voltages/current used by the I-7017 and M-7017 series:

| | | | | | | |
|------------|------|-----|-----|--------|--------|-------|
| Type Code | 08 | 09 | 0A | 0B | 0C | 0D |
| Zero Input | 0V | 0V | 0V | 0mV | 0mV | 0mA |
| Span Input | +10V | +5V | +1V | +500mV | +150mV | +20mA |

Calibration voltages/current used by the I-7017R-A5 and M-7017R-A5:

| | | |
|------------|-------|------|
| Type Code | 1B | 1C |
| Zero Input | 0V | 0V |
| Span Input | +150V | +50V |

Calibration voltages/current used by the I-7018 and M-7018 series:

| | | | | | | | |
|------------|-------|-------|--------|--------|-----|-------|-------|
| Type Code | 00 | 01 | 02 | 03 | 04 | 05 | 06 |
| Zero Input | 0mV | 0mV | 0mV | 0mV | 0V | 0V | 0mA |
| Span Input | +15mV | +50mV | +100mV | +500mV | +1V | +2.5V | +20mA |

Calibration voltages/current used by the I-7019 and M-7019 series:

| | | | | | | |
|--|-------|-------|--------|------------------|------------------|-------|
| Type Code | 00 | 01 | 02 | 03 | 04 | 05 |
| Zero Input | 0mV | 0mV | 0mV | 0mV | 0V | 0V |
| Span Input | +15mV | +50mV | +100mV | +500mV | +1V | +2.5V |
| Type Code | 06 | 08 | 09 | 0C ^{*1} | 10 ^{*2} | |
| Zero Input | 0mA | 0V | 0V | 0mV | 0mV | |
| Span Input | +20mA | +10V | +5V | +150mV | +35mV | |
| *1: for firmware version B2.7 and later. | | | | | | |
| *2: for firmware version B2.6 and earlier. | | | | | | |

1.11 Configuration Tables

Baud Rate Setting (CC)

| | | | | | | | |
|------|---|------|---|---|---|---|---|
| 7 | 6 | 5 | 4 | 3 | 2 | 1 | 0 |
| Data | | Baud | | | | | |

| Key | Description |
|------|--|
| Baud | Baud Rate 03: 1200 04: 2400 05: 4800 06: 9600 07: 19200 08: 38400 09: 57600 0A: 115200 |
| Data | Data Format 0: N81 1: N82 2: E81 3: O81 |

The firmware version that supports the data format other than N81 is as follows.

| Module | Firmware Version |
|-------------|------------------|
| 7017 series | B2.6 and later |
| 7018 series | B2.9 and later |
| 7018Z | B3.1 and later |
| 7019 series | B3.1 and later |

Analog Input Type Setting (TT)

| Type Code | Analog Input Type | Range |
|-----------|------------------------------|-----------------|
| 00 | +/-15mV | -15mV ~ 15mV |
| 01 | +/-50mV | -50mV ~ 50mV |
| 02 | +/-100mV | -100mV ~ 100mV |
| 03 | +/-500mV | -500mV ~ 500mV |
| 04 | +/-1V | -1V ~ 1V |
| 05 | +/-2.5V | -2.5V ~ 2.5V |
| 06 | +/-20mA | -20mA ~ 20mA |
| 07 | +4 to +20mA | 4mA ~ 20mA |
| 08 | +/-10V | -10V ~ 10V |
| 09 | +/-5V | -5V ~ 5V |
| 0A | +/-1V | -1V ~ 1V |
| 0B | +/-500mV | -500mV ~ 500mV |
| 0C | +/-150mV | -150mV ~ 150mV |
| 0D | +/-20mA | -20mA ~ 20mA |
| 0E | Type J Thermocouple | -210°C ~ 760°C |
| 0F | Type K Thermocouple | -270°C ~ 1372°C |
| 10 | Type T Thermocouple | -270°C ~ 400°C |
| 11 | Type E Thermocouple | -270°C ~ 1000°C |
| 12 | Type R Thermocouple | 0°C ~ 1768°C |
| 13 | Type S Thermocouple | 0°C ~ 1768°C |
| 14 | Type B Thermocouple | 0°C ~ 1820°C |
| 15 | Type N Thermocouple | -270°C ~ 1300°C |
| 16 | Type C Thermocouple | 0°C ~ 2320°C |
| 17 | Type L Thermocouple | -200°C ~ 800°C |
| 18 | Type M Thermocouple | -200°C ~ 100°C |
| 19 | Type L DIN43710 Thermocouple | -200°C ~ 900°C |
| 1A | 0 to +20mA | 0 ~ 20mA |
| Type Code | Analog Input Type | Range |
| 1B | +/-150V | -150V ~ 150V |
| 1C | +/-50V | -50V ~ 50V |

Note:

- Types 00, 01, 02, 03, 04, 05, 06, 0E, 0F, 10, 11, 12, 13, 14, 15 and 16 are only used in I-7018, M-7018, I-7019 and M-7019 series modules.

2. Types 17 and 18 are only used in the I-7018P, I-7018R, I-7018Z, M-7018R, M-7018Z, I-7019R, M-7019R and M-7019Z.
3. Type 19 is only used in I-7018R, I-7018Z, M-7018R, M-7018Z, I-7019R, M-7019R and M-7019Z.
4. Types 08, 09, 0A, 0B, 0C and 0D are only used in I-7017, M-7017, I-7019 and M-7019 series modules.
5. Types 07 and 1A are only used in I-7017 and M-7017 firmware version B2.2 and later, I-7018Z, M-7018Z, M-7019Z and I-7019R and M-7019R firmware version B2.7 and later.
6. Types 07, 0D, and 1A are not used in M-7017RMS.
7. Types 1B and 1C are only used in the I-7017R-A5 and M-7017R-A5.
8. When type 07, 0D or 1A is selected in I-7017, I-7017R, I-7017F, M-7017, M-7017R and M-7017F modules, an optional external 125-ohm resistor is required for each channel, as shown in Section 1.6.1.
9. When type 06 is selected in I-7018 and M-7018 series modules, an optional external 125-ohm resistor is required for each channel, as shown in Section 1.6.5.
10. When type 07 or 1A are selected in I-7018Z and M-7018Z, an optional external 125-ohm resistor is required for each channel, as shown in Section 1.6.5.
11. When type 06, 07, 0D or 1A is selected in I-7019 and M-7019 series modules, the jumper of the corresponding channel should be shorted, as shown in Section 1.7.2.

| Type | I-7017 I-7017F I-7017R M-7017 M-7017R M-7017RMS | I-7017C I-7017RC M-7017C M-7017RC M-7017mC-16 | I-7017R-A5 M-7017R-A5 | I-7018 M-7018 |
|-------------|--|---|--------------------------|------------------|
| 00 +/-15mV | | | | • |
| 01 +/-50mV | | | | • |
| 02 +/-100mV | | | | • |
| 03 +/-500mV | | | | • |
| 04 +/-1V | | | | • |
| 05 +/-2.5V | | | | • |
| 06 +/-20mA | | | | • |
| 07 4 ~ 20mA | B2,2 | B2.2 | | |
| 08 +/-10V | • | | | |
| 09 +/-5V | • | | | |
| 0A +/-1V | • | | | |
| 0B +/-500mV | • | | | |
| 0C +/-150mV | • | | | |
| 0D +/-20mA | • | • | | |
| 0E Type J | | | | • |
| 0F Type K | | | | • |
| 10 Type T | | | | • |
| 11 Type E | | | | • |
| 12 Type R | | | | • |
| 13 Type S | | | | • |
| 14 Type B | | | | • |
| 15 Type N | | | | • |
| 16 Type C | | | | • |
| 17 Type L | | | | |
| 18 Type M | | | | |
| 19 Type L2 | | | | |
| 1A 0 ~ 20mA | B2.2 | B2.2 | | |
| 1B +/-150V | | | • | |
| 1C +/-50V | | | • | |

Notes:

1. The strings, as B2.2, indicate the firmware version that supports the type.
2. Types 07, 0D, and 1A are not supported by M-7017RMS

| Type | I-7018P | I-7018R M-7018R | I-7018Z M-7018Z | I-7019R M-7019R M-7019Z |
|-------------|---------|--------------------|--------------------|-------------------------------|
| 00 +/-15mV | ● | ● | ● | ● |
| 01 +/-50mV | ● | ● | ● | ● |
| 02 +/-100mV | ● | ● | ● | ● |
| 03 +/-500mV | ● | ● | ● | ● |
| 04 +/-1V | ● | ● | ● | ● |
| 05 +/-2.5V | ● | ● | ● | ● |
| 06 +/-20mA | ● | ● | ● | ● |
| 07 4 ~ 20mA | | | ● | B2.7 |
| 08 +/-10V | | | | ● |
| 09 +/-5V | | | | ● |
| 0A +/-1V | | | | ● |
| 0B +/-500mV | | | | ● |
| 0C +/-150mV | | | | ● |
| 0D +/-20mA | | | | ● |
| 0E Type J | ● | ● | ● | ● |
| 0F Type K | ● | ● | ● | ● |
| 10 Type T | ● | ● | ● | ● |
| 11 Type E | ● | ● | ● | ● |
| 12 Type R | ● | ● | ● | ● |
| 13 Type S | ● | ● | ● | ● |
| 14 Type B | ● | ● | ● | ● |
| 15 Type N | ● | ● | ● | ● |
| 16 Type C | ● | ● | ● | ● |
| 17 Type L | ● | ● | ● | ● |
| 18 Type M | ● | ● | ● | ● |
| 19 Type L2 | | ● | ● | ● |
| 1A 0 ~ 20mA | | | ● | B2.7 |
| 1B +/-150V | | | | |
| 1C +/-50V | | | | |

Note: The strings, as B2.7, indicate the firmware version that supports the type.

Data Format Setting (FF)

| | | | | | | | |
|----|----|----|----------|---|---|----|---|
| 7 | 6 | 5 | 4 | 3 | 2 | 1 | 0 |
| FS | CS | MS | Reserved | | | DF | |

| Key | Description |
|-----|---|
| DF | Data format 00: Engineering unit 01: % of FSR (full scale range) 10: 2's complement hexadecimal |
| MS | Mode settings for I-7017F, I-7017FC, I-7017R, I-7017RC, I-7017R-A5, I-7017Z, M-7017R, M-7017RC, M-7017R-A5, M-7017mC-16 and M-7017Z 0: Normal mode (16 bits) 1: Fast mode (12 bits) Reserved for other modules and should be zero. |
| CS | Checksum settings 0: Disabled 1: Enabled |
| FS | Filter settings 0: 60Hz rejection 1: 50Hz rejection Reserved for the I-7019R and M-7019R firmware version B2.6 and earlier. |

Note: The reserved bits should be zero.

Analog Input Type and Data Format Table

| Type code | Input Type | Data Format | +F.S | -F.S. |
|------------------|--------------------|------------------|---------|---------|
| 00 ^{*1} | -15 to +15 mV | Engineering unit | +15.000 | -15.000 |
| | | % of FSR | +100.00 | -100.00 |
| | | 2's comp HEX | 7FFF | 8000 |
| 01 ^{*1} | -50 to +50 mV | Engineering unit | +50.000 | -50.000 |
| | | % of FSR | +100.00 | -100.00 |
| | | 2's comp HEX | 7FFF | 8000 |
| 02 ^{*1} | -100 to +100 mV | Engineering unit | +100.00 | -100.00 |
| | | % of FSR | +100.00 | -100.00 |
| | | 2's comp HEX | 7FFF | 8000 |
| 03 ^{*1} | -500 to +500 mV | Engineering unit | +500.00 | -500.00 |
| | | % of FSR | +100.00 | -100.00 |
| | | 2's comp HEX | 7FFF | 8000 |
| 04 ^{*1} | -1 to +1 V | Engineering unit | +1.0000 | -1.0000 |
| | | % of FSR | +100.00 | -100.00 |
| | | 2's comp HEX | 7FFF | 8000 |
| 05 ^{*1} | -2.5 to +2.5 V | Engineering unit | +2.5000 | -2.5000 |
| | | % of FSR | +100.00 | -100.00 |
| | | 2's comp HEX | 7FFF | 8000 |
| 06 ^{*1} | -20 to +20 mA | Engineering unit | +20.000 | -20.000 |
| | | % of FSR | +100.00 | -100.00 |
| | | 2's comp HEX | 7FFF | 8000 |
| 07 ^{*5} | +4 to +20 mA | Engineering unit | +20.000 | +04.000 |
| | | % of FSR | +100.00 | +000.00 |
| | | 2's comp HEX | FFFF | 0000 |
| 08 ^{*2} | -10 to +10 V | Engineering unit | +10.000 | -10.000 |
| | | % of FSR | +100.00 | -100.00 |
| | | 2's comp HEX | 7FFF | 8000 |
| 09 ^{*2} | -5 to +5 V | Engineering unit | +5.0000 | -5.0000 |
| | | % of FSR | +100.00 | -100.00 |
| | | 2's comp HEX | 7FFF | 8000 |

| Type code | Input Type | Data Format | +F.S | -F.S. |
|------------------|---|------------------|---------|---------|
| 0A ^{*2} | -1 to +1 V | Engineering unit | +1.0000 | -1.0000 |
| | | % of FSR | +100.00 | -100.00 |
| | | 2's comp HEX | 7FFF | 8000 |
| 0B ^{*2} | -500 to +500 mV | Engineering unit | +500.00 | -500.00 |
| | | % of FSR | +100.00 | -100.00 |
| | | 2's comp HEX | 7FFF | 8000 |
| 0C ^{*2} | -150 to +150 mV | Engineering unit | +150.00 | -150.00 |
| | | % of FSR | +100.00 | -100.00 |
| | | 2's comp HEX | 7FFF | 8000 |
| 0D ^{*2} | -20 to +20 mA | Engineering unit | +20.000 | -20.000 |
| | | % of FSR | +100.00 | -100.00 |
| | | 2's comp HEX | 7FFF | 8000 |
| 0E ^{*1} | Type J Thermocouple -210 ~ 760°C | Engineering unit | +760.00 | -210.00 |
| | | % of FSR | +100.00 | -027.63 |
| | | 2's comp HEX | 7FFF | DCA2 |
| 0F ^{*1} | Type K Thermocouple -270 ~ 1372°C | Engineering unit | +1372.0 | -0270.0 |
| | | % of FSR | +100.00 | -019.68 |
| | | 2's comp HEX | 7FFF | E6D0 |
| 10 ^{*1} | Type T Thermocouple -270 ~ 400°C | Engineering unit | +400.00 | -270.00 |
| | | % of FSR | +100.00 | -067.50 |
| | | 2's comp HEX | 7FFF | A99A |
| 11 ^{*1} | Type E Thermocouple -270 ~ 1000°C | Engineering unit | +1000.0 | -0270.0 |
| | | % of FSR | +100.00 | -027.00 |
| | | 2's comp HEX | 7FFF | DD71 |
| 12 ^{*1} | Type R Thermocouple 0 ~ 1768°C | Engineering unit | +1768.0 | +0000.0 |
| | | % of FSR | +100.00 | +000.00 |
| | | 2's comp HEX | 7FFF | 0000 |
| 13 ^{*1} | Type S Thermocouple 0 ~ 1768°C | Engineering unit | +1768.0 | +0000.0 |
| | | % of FSR | +100.00 | +000.00 |
| | | 2's comp HEX | 7FFF | 0000 |
| 14 ^{*1} | Type B Thermocouple 0 ~ 1820°C | Engineering unit | +1820.0 | +0000.0 |
| | | % of FSR | +100.00 | +000.00 |
| | | 2's comp HEX | 7FFF | 0000 |

| Type code | Input Type | Data Format | +F.S | -F.S. |
|------------------|--|------------------|---------|---------|
| 15 ^{*1} | Type N Thermocouple -270 ~ 1300°C | Engineering unit | +1300.0 | -0270.0 |
| | | % of FSR | +100.00 | -020.77 |
| | | 2's comp HEX | 7FFF | E56B |
| 16 ^{*1} | Type C Thermocouple 0 ~ 2320°C | Engineering unit | +2320.0 | +0000.0 |
| | | % of FSR | +100.00 | +000.00 |
| | | 2's comp HEX | 7FFF | 0000 |
| 17 ^{*3} | Type L Thermocouple -200 ~ 800°C | Engineering unit | +800.00 | -200.00 |
| | | % of FSR | +100.00 | -025.00 |
| | | 2's comp HEX | 7FFF | E000 |
| 18 ^{*3} | Type M Thermocouple -200 ~ 100°C | Engineering unit | +100.00 | -200.00 |
| | | % of FSR | +050.00 | -100.00 |
| | | 2's comp HEX | 4000 | 8000 |
| 19 ^{*4} | Type L _{DIN43710} Thermocouple -200 ~ 900°C | Engineering unit | +900.00 | -200.00 |
| | | % of FSR | +100.00 | -022.22 |
| | | 2's comp HEX | 7FFF | E38E |
| 1A ^{*5} | 0 to +20 mA | Engineering unit | +20.000 | +00.000 |
| | | % of FSR | +100.00 | +000.00 |
| | | 2's comp HEX | FFFF | 0000 |
| 1B ^{*6} | -150 to +150 V | Engineering unit | +150.00 | -150.00 |
| | | % of FSR | +100.00 | -100.00 |
| | | 2's comp HEX | 7FFF | 8000 |
| 1C ^{*6} | -50 to +50 V | Engineering unit | +50.000 | -50.000 |
| | | % of FSR | +100.00 | -100.00 |
| | | 2's comp HEX | 7FFF | 8000 |

*1: only available with the I-7018, M-7018, I-7019 and M-7019 series

*2: only available with the I-7017, M-7017, I-7019 and M-7019 series

*3: only available with the I-7018P, I-7018Z, M-7018Z, I-7019R, M-7019R and M-7019Z.

*4: only available with the I-7019 and M-7019 series.

*5: only available with I-7017/M-7017 firmware version B2.2 and later, I-7018Z, M-7018Z, M-7019Z and I-7019R/M-7019R firmware version B2.7 and later.

*6: only available with I-7017R-A5 and M-7017R-A5

Thermocouple Over Range/Under Range Reading for the I-7018 series, version B1.4 and earlier.

| | Over Range | Under Range |
|--------------------|------------|-------------|
| Engineering Unit | +9999 | -0000 |
| % of FSR | +9999 | -0000 |
| 2's Complement HEX | +9999 | -0000 |

Thermocouple Over Range/Under Range Reading for the I-7018 series, version B1.5 and later, M-7018 series, I-7019 series and the M-7019 series

| | Over Range | Under Range |
|--------------------|------------|-------------|
| Engineering Unit | +9999.9 | -9999.9 |
| % of FSR | +999.99 | -999.99 |
| 2's Complement HEX | 7FFF | 8000 |

Thermocouple Over Range/Under Range Reading for the M-7018 series and the M-7019 series with Modbus RTU protocol

| Over Range | Under Range |
|------------|-------------|
| 7FFFh | 8000h |

4 ~ 20mA Under Range Reading

| | Modbus RTU | DCON |
|--------------------|------------|---------|
| Engineering Unit | -32768 | -9999.9 |
| % of FSR | | -999.99 |
| 2's Complement HEX | 0000h | 0000 |

1.12 M-7000 Notes

The main difference between the I-7000 and M-7000 series is that the M-7000 series has additional support for the Modbus RTU communication protocol, which is the default protocol of the M-7000 series. The communication Baud Rates for the Modbus RTU protocol can be in the range of 1200 bps to 115200 bps, and the parity, data and stop bits are fixed as no parity, 8 data bits and 1 stop bit.

Modbus functions supported by the module are described in Chapter 3.

1.12.1 Protocol Switching

To switch to the DCON protocol:

1. Uses sub-function 06h of the function 46h and set byte 8 to a value of 1. See Section 3.3.4 for details.
2. After a power-on reset, the communication protocol will be changed to DCON.

To switch to the Modbus RTU protocol:

1. Sends the \$AAPN command and set N to a value of 1. Note that the slide switch on the rear side of the module should be set to the INIT position, see the figure on the next page. See Section 2.26 for details.
2. After a power-on reset, the communication protocol will be changed to the Modbus RTU protocol.

1.12.2 INIT Mode

When the module is powered on, with the rear slide switch set to the INIT position as shown in the figure below, the module is in INIT mode, (see Section A.1 for details), and the communication settings are as follows:

1. Address: 00
2. Baud Rate: 9600 bps
3. No checksum
4. Protocol: DCON

If communication with the module is not possible, set the module to the INIT mode and use the above settings to communicate with the module. To read the current settings, send the commands \$AA2, (see Section 2.10), and \$AAP, (see Section 2.25). To set new settings, send the commands %AANNTCCFF, (see Section 2.1) and \$AAPN, (see Section 2.26). The new communication settings will be effective after the next power-on reset.

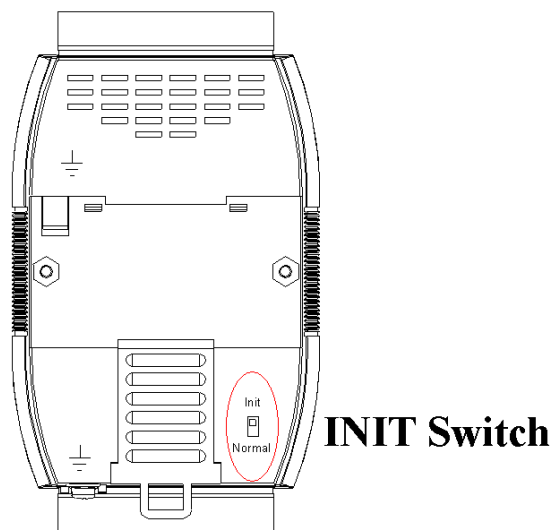

1.13 Mounting

1.13.1 DIN Rail Mounting

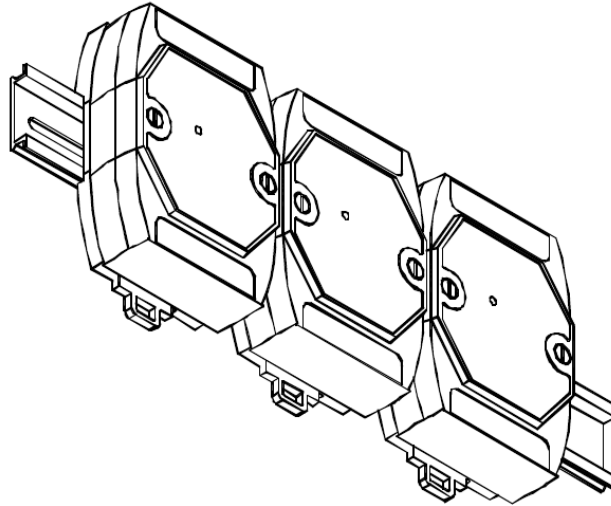

There are three new DIN rail models available. Each are made of stainless steel, which is stronger than those made of aluminum. There is a screw at one end and a ring terminal is included so that it can be easily connected to the earth ground. The three new DIN rail models are as follows.

| Part number | Max number of modules | Dimensions |
|-------------|-----------------------|--------------|
| DRS-360 | 5 | 360mm x 35mm |

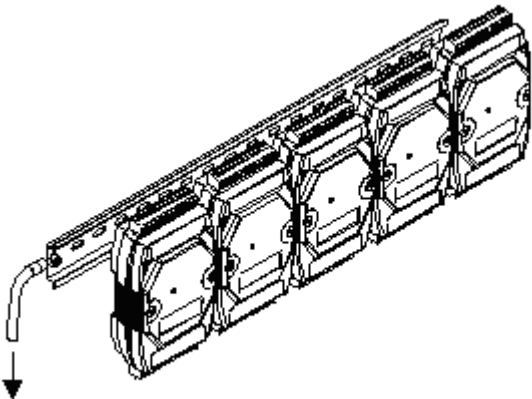

to earth ground

| Part number | Max number of modules | Dimensions |
|-------------|-----------------------|--------------|
| DRS-240 | 3 | 240mm x 35mm |

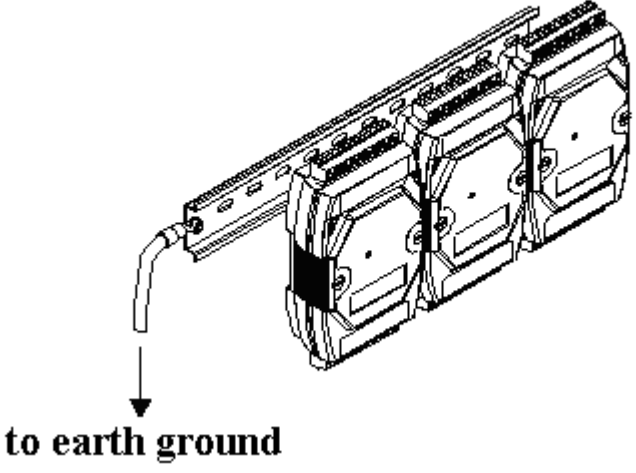

to earth ground

| Part number | Max number of modules | Dimensions |
|-------------|-----------------------|--------------|
| DRS-125 | 2 | 125mm x 35mm |

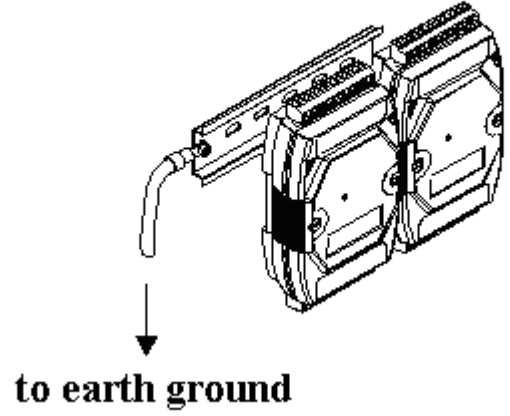

to earth ground

Note: The recommended wire to connect to the earth ground is 16 – 14 AWG wire.

1.13.2 Piggyback Mounting

For I-7017, I-7017F, I-7018, I-7018P and I-7018BL modules

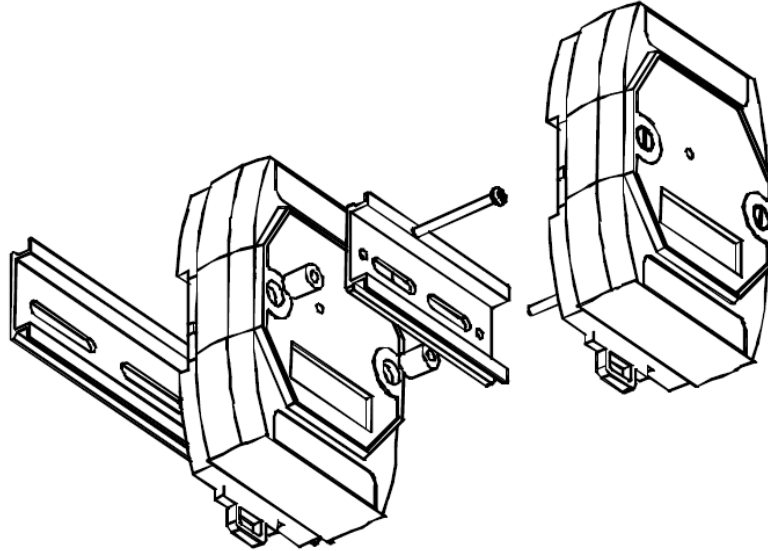

For other modules

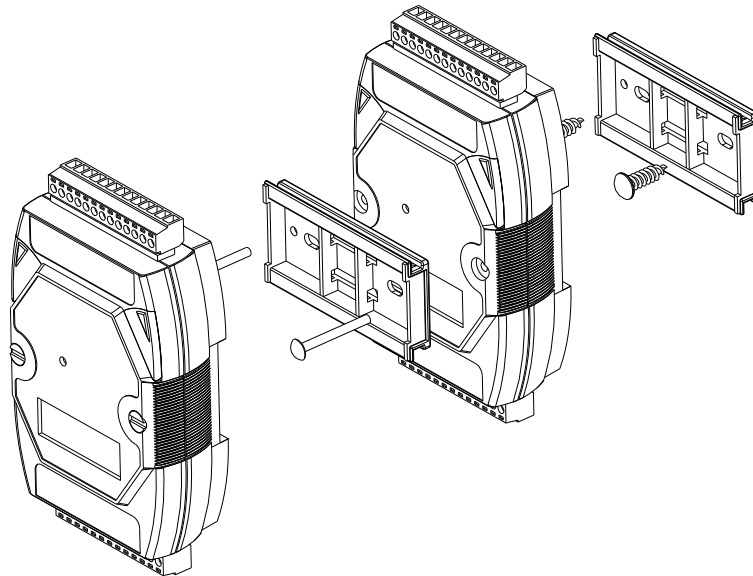

1.13.3 Wall Mounting

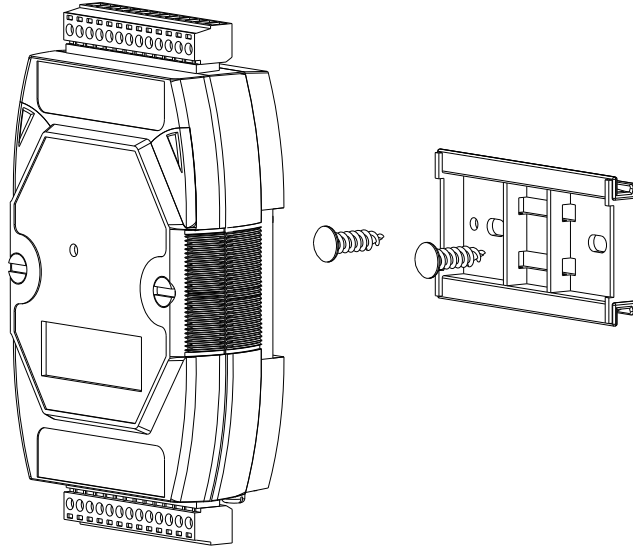

1.14 Technical Support

Should you encounter problems while using the I-7000 and M-7000 module, and are unable to find the help you need in this manual or on our website, please contact ICP DAS Product Support.

Email: service@icpdas.com

Website: http://www.icpdas.com.tw/contact_us/contact_us.html

When requesting technical support, be prepared to provide the following information about your system:

1. Module name and serial number: The serial number can be found printed on the barcode label attached to the cover of the module.
2. Firmware version: See Section 2.23 and 3.3.7 for information regarding the command used to identify the firmware version.
3. Host configuration (type and operating system)
4. If the problem is reproducible, please give full details describing the procedure used to reproduce the problem.
5. Specific error messages displayed. If a dialog box with an error message is displayed, please include the full text of the dialog box, including the text in the title bar.
6. If the problem involves other programs or hardware devices, please describe the details of the problem in full.
7. Any comments and suggestions related to the problem are welcome.

ICP DAS will reply to your request by email within three business days.

2. DCON Protocol

All communication with I-7000 modules consists of commands generated by the host and responses transmitted by the I-7000 modules. Each module has a unique ID number that is used for addressing purposes and is stored in non-volatile memory. The ID is 01 by default and can be changed using a user command. All commands to the modules contain the ID address, meaning that only the addressed module will respond. The only exception to this is commands #** (Section 2.2) and ~** (Section 2.35), which are sent to all modules, but in these cases, the modules do not reply to the command.

Command Format:

| | | | | |
|--------------------------|-----------------------|----------------|-----------------|-----------|
| Leading Character | Module Address | Command | [CHKSUM] | CR |
|--------------------------|-----------------------|----------------|-----------------|-----------|

Response Format:

| | | | | |
|--------------------------|-----------------------|-------------|-----------------|-----------|
| Leading Character | Module Address | Data | [CHKSUM] | CR |
|--------------------------|-----------------------|-------------|-----------------|-----------|

CHKSUM A 2-character checksum that is present when the checksum setting is enabled. See Section 1.11 and 2.1 for details.

CR End of command character, carriage return (0x0D)

Checksum Calculation:

1. Calculate the ASCII code sum of all the characters in the command/response string except for the carriage return character (CR).
2. The checksum is equal to the sum masked by 0ffh.

Example:

Command string: \$012(CR)

1. Sum of the string = “\$”+”0”+”1”+”2” =
 $24h+30h+31h+32h = B7h$
2. Therefore the checksum is B7h, and so
CHKSUM = “B7”
3. The command string with the checksum = \$012B7(CR)

Response string: !01200600(CR)

1. Sum of the string =
“!”+”0”+”1”+”2”+”0”+”0”+”6”+”0”+”0” =
 $21h+30h+31h+32h+30h+30h+36h+30h+30h = 1AAh$
2. Therefore the checksum is AAh, and so
CHKSUM = “AA”
3. The response string with the checksum
= !01200600AA(CR)

Note:

All characters should be in upper case.

| General Command Sets | | | |
|----------------------|-------------|--|---------|
| Command | Response | Description | Section |
| %AANNTTCCFF | !AA | Set Module Configuration | 2.1 |
| #** | No Response | Synchronized Sampling | 2.2 |
| #AA | >(Data) | Reads the Analog Inputs of All Channels | 2.3 |
| #AAN | >(Data) | Reads the Analog Input of the Specified Channel | 2.4 |
| \$AA0 | !AA | Performs a Span Calibration | 2.5 |
| \$AA1 | !AA | Performs a Zero Calibration | 2.6 |
| \$AA0Ci | !AA | Performs a Single Channel Span Calibration for Current Input | 2.7 |
| \$AA0Ci | !AA | Performs a Single Channel Zero Calibration | 2.8 |
| \$AA1Ci | !AA | Performs a Single Channel Span Calibration | 2.9 |
| \$AA2 | !AANNTTCCFF | Reads the Module Configuration | 2.10 |
| \$AA3 | >(Data) | Reads the CJC Temperature | 2.11 |
| \$AA4 | >AAS(Data) | Reads the Synchronized Data | 2.12 |
| \$AA5VV | !AA | Enables/Disables the Channel | 2.13 |
| \$AA6 | !AAVV | Reads the Channel Enable/Disable Status | 2.14 |
| \$AA7CiRrr | !AA | Sets the Single Channel Range Configuration | 2.15 |
| \$AA8Ci | !AACiRrr | Reads the Single Channel Range Configuration | 2.16 |
| \$AA9 | !AA(Data) | Reads the CJC Offset | 2.17 |
| \$AA9SNNNN | !AA | Sets the CJC Offset | 2.18 |
| \$AAA | >(data) | Reads the Analog Inputs of All Channels in Hex Format | 2.19 |
| \$AAA | !AAi | Reads the CJC Update Setting | 2.20 |
| \$AAAi | !AA | Sets the CJC Update Setting | 2.21 |
| \$AAB | !AANN | Reads the Channel Diagnostic Status | 2.22 |
| \$AAF | !AA(Data) | Reads the Firmware Version | 2.23 |
| \$AAM | !AA(Data) | Reads the Module Name | 2.24 |
| \$AAP | !AASC | Reads the Protocol | 2.25 |
| \$AAPN | !AA | Sets the Protocol | 2.26 |

| Command | Response | Description | Section |
|------------|----------|---|---------|
| \$AAS0 | !AA | Internal Calibration | 2.27 |
| \$AAS1 | !AA | Reloads the Default Calibration Parameters | 2.28 |
| ~AAC | !AAN | Reads the CJC Enable/Disable | 2.29 |
| ~AACN | !AA | Enables/Disables the CJC | 2.30 |
| ~AAEV | !AA | Enables/Disables the Calibration | 2.31 |
| ~AAI | !AA | Soft INIT | 2.32 |
| ~AAO(Name) | !AA | Sets the Module Name | 2.33 |
| ~AATnn | !AA | Sets the Soft INIT Timeout | 2.34 |
| ~AAEO | !AAN | Reads the Open Wire Detection Enable/Disable | 2.40 |
| ~AAEON | !AA | Enable/Disable Open Wire Detection | 2.41 |
| @AAS | !AAN | Read connecting mode | 2.42 |
| @AASN | !AA | Set connecting mode to differential or single-ended | 2.43 |

| Host Watchdog Command Sets | | | |
|----------------------------|-------------|--|---------|
| Command | Response | Description | Section |
| ~** | No Response | Host OK | 2.35 |
| ~AA0 | !AASS | Reads the Host Watchdog Status | 2.36 |
| ~AA1 | !AA | Resets the Host Watchdog Status | 2.37 |
| ~AA2 | !AAETT | Reads the Host Watchdog Timeout Settings | 2.38 |
| ~AA3ETT | !AA | Sets the Host Watchdog Timeout Settings | 2.39 |

2.1 %AANNTTCCFF

Description:

Sets the configuration of an analog input module.

Syntax:

%AANNTTCCFF[CHKSUM](CR)

- %** Delimiter character
- AA** Address of the module to be configured in hexadecimal format (00 to FF)
- NN** New address of the module in hexadecimal format (00 to FF)
- TT** New type code, see Section 1.11 for details. Not used by the I-7017Z, M-7017Z, M-7017mC-16, I-7018Z, M-7018Z, I-7019 series and M-7019 series. For the I-7017Z, M-7017Z, M-7017mC-16, I-7018Z, M-7018Z, I-7019 series and M-7019 series, use the \$AA7CiRrr command to set the type of each channel, see Section 2.15 for details.
- CC** New Baud Rate code, see Section 1.11 for details. To change the Baud Rate, the INIT* terminal must be connected to ground or the rear slide switch must be set to the INIT position. See Section A.1 for details.
- FF** Used to set the data format, checksum, and filter settings (Section 1.11). To change the checksum setting, the INIT* terminal must be connected to ground or the rear slide switch must be set to the INIT position. See Section A.1 for details.

Notes:

1. For I-7017R and M-7017R firmware version B3.9 and later, I-7018R firmware version B4.2 and later, M-7018R firmware version B4.5 and later, and M-7017RMS, the type codes can be set by both the TT field and the \$AA7CiRrr command. For these modules, if not all of the type codes are the same, then the TT field should be set to FF.
2. The filter setting is not available in the I-7019R and M-7019R firmware version B2.6 and earlier.

Response:

Valid Response: **!AA[CHKSUM](CR)**

Invalid Response: **?AA[CHKSUM](CR)**

! Delimiter character for a valid response

? Delimiter character for an invalid response. If changing the **Baud Rate** or **checksum** settings without connecting the INIT* pin to ground or switching the rear slide switch to the INIT position, the module will return an invalid command.

AA Address of the module in hexadecimal format (00 to FF)

There will be no response if the command syntax is incorrect, there is a communication error, or there is no module with the specified address.

Examples:

Command: %0102000600 Response: !02
Change the address of module 01 to 02. The module returns a valid response.

Command: %0202000602 Response: !02
Set the data format of module 02 to be 2 (2's complement hexadecimal). The module returns a valid response.

Command: %0101000A00 Response: ?01
Change the Baud Rate of module 01 to 115200bps. The module returns an invalid command, because it is not in INIT* mode.

Command: %0101000A00 Response: !01
Change the Baud Rate of module 01 to 115200bps and the module is in INIT* mode. The module returns a valid response.

Related Commands:

Section 2.10 \$AA2, Section 2.32 ~AAI, Section 2.34
~AATnn

Related Topics:

Section 1.11 Configuration Tables, Section A.1 INIT Mode

Notes:

1. Changes to the address, type code, data format and filter settings take effect immediately after a valid command is received. Changes to the Baud Rate and checksum settings take effect on the next power on reset.
2. For the M-7017mC-16, I-7019 and M-7019 series modules, changing the Baud Rate and checksum settings can be achieved using software only and is performed using the following commands:
 - I. Send a ~AATnn command. See Section 2.34 for details.
 - II. Send a ~AAI command. See Section 2.32 for details.
 - III. Send a %AANNTTCCFF command.
If the command is valid, the Baud Rate and checksum settings will be changed after the module responds with !AA.

2.2 #**

Description:

This command allows every analog input module to read data from every input channels when the command is received and will store the data for later retrieval.

Syntax:

#**[CHKSUM](CR)

Delimiter character

** Synchronized sampling command

Response:

There is no response with this command. To access the data, another command, \$AA4, must be sent, see Section 2.12 for details.

Examples:

Command: #**

No response

Sends the synchronized sampling command.

Command: \$014

Response:

>011+025.12+020.45+012.78+018.97+003.24+015.35+00
8.07+014.79

Sends the command to read the synchronized data.
The status byte of the response is 1, which means
that it is the first time the synchronized data has
been read since the previous #** command.

Command: \$014

Response:

>010+025.12+020.45+012.78+018.97+003.24+015.35+00
8.07+014.79

Sends the command to read the synchronized data.
The status byte of the response is 0, which means
that it is **NOT** the first time the synchronized data
has been read since the previous #** command.

Related Commands:

Section 2.12 \$AA4

Note:

1. This command is only applicable to I-7019 and M-7019 series modules.
2. After sending this command, there must be a 2ms delay before the next command can be sent.

2.3 #AA

Description:

Reads the data from every analog input channel.

Syntax:

#AA[CHKSUM](CR)

Delimiter character

AA Address of the module to be read (00 to FF)

Response:

Valid Response: >(Data)[CHKSUM](CR)

Invalid Response: ?AA[CHKSUM](CR)

> Delimiter character for a valid response

? Delimiter character for an invalid response

(Data) Data from every analog input channels, see Section 1.11 for the details of data format. For the I-7019 and M-7019 series, data from disabled channels will be filled with space characters.

There will be no response if the command syntax is incorrect, there is a communication error, or there is no module with the specified address.

Examples:

Command: #01 Response:
>+025.12+020.45+012.78+018.97+003.24+015.35+008.0
7+014.79

 Reads module 01 and receives the data in engineering format.

Command: #02 Response:
>4C532628E2D683A20F2ADBA16284BA71

 Reads module 02 and receives the data in hexadecimal format.

Command: #03 Response:
>-9999.9-9999.9-9999.9-9999.9-9999.9-9999.9-9999.9-
9999.9

 Reads module 03 and the data is under range.

Related Commands:

Section 2.1 %AANNTTCCFF, Section 2.10 \$AA2

Related Topics:

Section 1.11 Configuration Tables

2.4 #AAN, #AANN

Description:

Reads the analog input of channel N.

Syntax:

#AAN[CHKSUM](CR)

- # Delimiter character
- AA Address of the module to be read (00 to FF)
- N The channel to be read, zero based.
- NN For I-7017Z and M-7017Z single-end mode, the channel to be read, zero based in hex format.

Response:

Valid Response: >(Data)[CHKSUM](CR)

Invalid Response: ?AA[CHKSUM](CR)

- > Delimiter character for a valid response
- ? Delimiter character for an invalid response. An invalid command is returned if the specified channel is incorrect.
- (Data) Analog input data of the specified channel, see Section 1.11 for details of the data format. For I-7019 and M-7019 series modules, if the specified channel is disabled then the data field will be filled with space characters.
- AA Address of the responding module (00 to FF)

There will be no response if the command syntax is incorrect, there is a communication error, or there is no module with the specified address.

I-7017, I-7018, I-7019 series
M-7017, M-7018, M-7019 series

Examples:

| | |
|--|--------------------|
| Command: #032 | Response: >+025.13 |
| Reads data from channel 2 of module 03. | |
| Command: #0511 | Response: >+025.13 |
| Reads data from channel 17 of module 05 for an I-7017Z in single-ended mode. | |
| Command: #029 | Response: ?02 |
| Reads data from channel 9 of module 02. An error is returned because channel 9 is invalid. | |

Related Commands:

Section 2.1 %AANNTTCCFF, Section 2.10 \$AA2

Related Topics:

Section 1.11 Configuration Tables

2.5 \$AA0

Description:

Performs a span calibration.

Syntax:

\$AA0[CHKSUM](CR)

\$ Delimiter character

AA Address of the module to be calibrated (00 to FF)

0 Command for the span calibration

Response:

Valid Response: **!AA[CHKSUM](CR)**

Invalid Response: **?AA[CHKSUM](CR)**

! Delimiter character for a valid response

? Delimiter character for an invalid response

AA Address of the responding module (00 to FF)

There will be no response if the command syntax is incorrect, there is a communication error, or there is no module with the specified address.

Examples:

Command: \$010

Response: !01

Performs a span calibration on module 01 and returns a valid response.

Command: \$020

Response: ?02

Performs a span calibration on module 02. An invalid command is returned because the “enable calibration” command was not sent in advance.

Related Commands:

Section 2.6 \$AA1, Section 2.31 ~AAEV

Related Topics:

Section 1.10 Calibration

Notes:

1. This command is only applicable to I-7017, I-7018, M-7017 and M-7018 series modules.
2. This command is also applicable to I-7017Z, I-7018Z, M-7017mC-16, M-7017Z and M-7018Z.
3. The “enable calibration” command, ~AAEV, must be sent before this command is used, see Section 1.10 for details.

2.6 \$AA1

Description:

Performs a zero calibration.

Syntax:

\$AA1[CHKSUM](CR)

\$ Delimiter character

AA Address of the module to be set (00 to FF)

1 Command for the zero calibration

Response:

Valid Response: **!AA[CHKSUM](CR)**

Invalid Response: **?AA[CHKSUM](CR)**

! Delimiter character for a valid response

? Delimiter character for an invalid response

AA Address of the responding module (00 to FF)

There will be no response if the command syntax is incorrect, there is a communication error, or there is no module with the specified address.

Examples:

Command: \$011 Response: !01
 Performs a zero calibration on module 01 and
 returns a valid response.

Command: \$021 Response: ?02
 Performs a zero calibration on module 02. An
 invalid command is returned because the “enable
 calibration” command was not sent in advance.

Related Commands:

Section 2.5 \$AA0, Section 2.31 ~AAEV

Related Topics:

Section 1.10 Calibration

Notes:

1. This command is only applicable to I-7017, I-7018, M-7017 and M-7018 series modules.
2. This command is also applicable to I-7017Z, I-7018Z, M-7017mC-16, M-7017Z and M-7018Z.
3. The “enable calibration” command, ~AAEV, must be sent before this command is used, see Section 1.10 for details.

2.7 \$AA0Ci

Description:

Performs a span calibration on the specified current input channel.

Syntax:

\$AA0Ci[CHKSUM](CR)

\$ Delimiter character

AA Address of the module to be calibrated (00 to FF)

0 Command for the current input span calibration

Ci Specifies the channel to be calibrated

Response:

Valid Response: !AA[CHKSUM](CR)

Invalid Response: ?AA[CHKSUM](CR)

! Delimiter character for a valid response

? Delimiter character for an invalid response. An invalid command is returned if the specified channel is incorrect.

AA Address of the responding module (00 to FF)

There will be no response if the command syntax is incorrect, there is a communication error, or there is no module with the specified address.

Examples:

Command: \$010C0 Response: !01
Performs a span calibration on channel 0 of module 01 and returns a valid response.

Command: \$020C5 Response: !02
Performs a span calibration on channel 5 of module 02 and returns a valid response.

Command: \$030C1 Response: ?03
Performs a span calibration on channel 1 of module 03. An invalid command is returned because the “enable calibration” command was not sent in advance.

Related Commands:

Section 2.5 \$AA0, Section 2.6 \$AA1, Section 2.31~AAEV

Related Topics:

Section 1.10 Calibration

Notes:

- 1 This command is only applicable to M-7017mC-16.
- 2 The “enable calibration” command, ~AAEV, must be sent before this command is used, see Section 1.10 for details.

2.8 \$AA0Ci

Description:

Performs a zero calibration on the specified channel.

Syntax:

\$AA0Ci[CHKSUM](CR)

\$ Delimiter character

AA Address of the module to be calibrated (00 to FF)

0 Command for the zero calibration

Ci Specifies the channel to be calibrated

Response:

Valid Response: !AA[CHKSUM](CR)

Invalid Response: ?AA[CHKSUM](CR)

! Delimiter character for a valid response

? Delimiter character for an invalid response. An invalid command is returned if the specified channel is incorrect.

AA Address of the responding module (00 to FF)

There will be no response if the command syntax is incorrect, there is a communication error, or there is no module with the specified address.

Examples:

Command: \$010C0 Response: !01
Performs a zero calibration on channel 0 of module 01 and returns a valid response.

Command: \$020C5 Response: !02
Performs a zero calibration on channel 5 of module 02 and returns a valid response.

Command: \$030C1 Response: ?03
Performs a zero calibration on channel 1 of module 03. An invalid command is returned because the “enable calibration” command was not sent in advance.

Related Commands:

Section 2.9 \$AA1Ci, Section 2.31~AAEV

Related Topics:

Section 1.10 Calibration

Notes:

- 3 This command is only applicable to I-7019 and M-7019 series modules.
- 4 The “enable calibration” command, ~AAEV, must be sent before this command is used, see Section 1.10 for details.
- 5 This command takes about 16 seconds for firmware version B2.6 and earlier.

2.9 \$AA1Ci

Description:

Performs a span calibration on the specified channel.

Syntax:

\$AA1Ci[CHKSUM](CR)

\$ Delimiter character

AA Address of the module to be calibrated (00 to FF)

1 Command for the span calibration

Ci Specifies the channel to be calibrated

Response:

Valid Response: !AA[CHKSUM](CR)

Invalid Response: ?AA[CHKSUM](CR)

! Delimiter character for a valid response

? Delimiter character for an invalid response. An invalid command is returned if the specified channel is incorrect.

AA Address of the responding module (00 to FF)

There will be no response if the command syntax is incorrect, there is a communication error, or there is no module with the specified address.

Examples:

Command: \$011C0 Response: !01
Performs a span calibration on channel 0 of module 01 and returns a valid response.

Command: \$021C5 Response: !02
Performs a span calibration on channel 5 of module 02 and returns a valid response.

Command: \$031C1 Response: ?03
Performs a span calibration on channel 1 of module 03. An invalid command is returned because the “enable calibration” command was not sent in advance.

Related Commands:

Section 2.8 \$AA0Ci, Section 2.31 ~AAEV

Related Topics:

Section 1.10 Calibration

Notes:

1. This command is only applicable to I-7019 and M-7019 series modules
2. The “enable calibration” command, ~AAEV, must be sent before this command is used, see Section 1.10 for details.
3. This command takes about 16 seconds for firmware version B2.6 and earlier.

2.10 \$AA2

Description:

Reads the module configuration.

Syntax:

\$AA2[CHKSUM](CR)

\$ Delimiter character
AA Address of the module to be read (00 to FF)
2 Command to read the module configuration

Response:

Valid Response: **!AATCCFF[CHKSUM](CR)**

Invalid Response: **?AA[CHKSUM](CR)**

! Delimiter character for a valid response
? Delimiter character for an invalid response
AA Address of the responding module (00 to FF)
TT Type code of the module, see Section 1.11 for details.
CC Baud Rate code of the module, see Section 1.11 for details.
FF Data format, checksum settings and filter settings of the module, see Section 1.11 for details.

There will be no response if the command syntax is incorrect, there is a communication error, or there is no module with the specified address.

I-7017, I-7018, I-7019 series
M-7017, M-7018, M-7019 series

Examples:

Command: \$012 Response: !01050600
Reads the configuration of module 01.
Command: \$022 Response: !02030602
Reads the configuration of module 02.

Related Commands:

Section 2.1 %AANNTTCFF

Related Topics:

Section 1.11 Configuration Tables, Section A.1 INIT
Mode

Note:

For I-7017R and M-7017R firmware version B3.9 and later, I-7018R firmware version B4.2 and later, M-7018R firmware version B4.5 and later, and M-7017RMS, the type codes can be set by both the %AANNTTCFF and the \$AA7CiRrr commands. For these modules, if not all of the type codes are the same, then the TT field will be FF.

2.11 \$AA3

Description:

Reads the CJC (cold junction compensation) temperature.

Syntax:

\$AA3[CHKSUM](CR)

\$ Delimiter character

AA Address of the module to be read (00 to FF)

3 Command to read the CJC temperature

Response:

Valid Response: **>(Data)[CHKSUM](CR)**

Invalid Response: **?AA[CHKSUM](CR)**

> Delimiter character for a valid response

? Delimiter character for an invalid response

AA Address of the responding module (00 to FF)

(Data) CJC temperature in degrees Celsius, consisting of a sign byte, '+' or '-', and followed by 5 decimal digits with a fixed decimal point in tenths of a degree.

There will be no response if the command syntax is incorrect, there is a communication error, or there is no module with the specified address.

Examples:

Command: \$013 Response: >+0031.2
Reads the CJC temperature of module 01 and the
module responds with 31.2°C.

Related Commands:

Section 2.17 \$AA9, Section 2.18 \$AA9SNNNN, Section
2.20 \$AAA, Section 2.21 \$AAAi, Section 2.29 ~AAC,
Section 2.30 ~AACN

Notes:

1. This command is only applicable to I-7018, I-7019, M-7018 and M-7019 series modules.
2. For I-7018 and M-7018 series modules, the CJC offset is included in the reported CJC temperature. For I-7019 and M-7019 series modules, the CJC offset is not included.

2.12 \$AA4

Description:

Reads the synchronized data that was obtained from the last #** command.

Syntax:

\$AA4[CHKSUM](CR)

\$ Delimiter character
AA Address of the module to be read (00 to FF)
4 Command to read the synchronized data

Response:

Valid Response: **>AAS(Data)[CHKSUM](CR)**

Invalid Response: **?AA[CHKSUM](CR)**

> Delimiter character for a valid response
? Delimiter character for an invalid response
AA Address of the responding module (00 to FF)
S Status of the synchronized data,
 1: first reading
 0: not the first reading
(Data) Synchronized data. See Section 1.11 for details
 of the data format. For I-7019 and M-7019
 series modules, data from disabled channels will
 be filled with space characters.

There will be no response if the command syntax is incorrect, there is a communication error, or there is no module with the specified address.

Examples:

Command: \$014

Response: ?01

Reads the synchronized data for module 01. An invalid command is returned because the #** command has not been sent in advance.

Command: #**

No response

Sends the synchronized sampling command.

Command: \$014

Response:

>011+025.56+002.34+015.79+022.66+008.53+021.43+007.06+022.88

Reads the synchronized data for module 01. The module returns the synchronized data and sets the status byte to 1 to indicate that it is the first time the synchronized data has been read.

Command: \$014

Response:

>010+25.56+002.34+015.79+022.66+008.53+021.43+007.06+022.88

Reads the synchronized data for module 01. The module returns the synchronized data and sets the status byte to 0 to indicate that the synchronized data has been read.

Related Commands:

Section 2.2 #**

Note:

This command is only applicable to I-7019 and M-7019 series modules.

2.13 \$AA5VV, \$AA5VVVV

Description:

Specifies the channel(s) to be enabled.

Syntax:

\$AA5VV(VV)[CHKSUM](CR)

\$ Delimiter character
AA Address of the module to be set (00 to FF)
5 Command to set the channel(s) to enabled
VV(VV) A two-digit hexadecimal value, where bit 0 corresponds to channel 0, bit 1 corresponds to channel 1, etc. When the bit is 1 it means that the channel is enabled and 0 means that the channel is disabled. It is four-digit hexadecimal for I-7017Z, M-7017Z, M-7017mC-16, I-7018Z, M-7018Z and M-7019Z. Note: it is six-digit hexadecimal for I-7017Z and M-7017Z in single-ended mode.

Response:

Valid Response: **!AA[CHKSUM](CR)**

Invalid Response: **?AA[CHKSUM](CR)**

! Delimiter character for a valid response
? Delimiter character for an invalid response. An invalid command is returned if an attempt is made to enable a channel that is not present.
AA Address of the responding module (00 to FF)

There will be no response if the command syntax is incorrect, there is a communication error, or there is no module with the specified address.

Examples:

Command: \$0153A Response: !01
Enables channels 1, 3, 4, and 5 and disables all other channels of module 01. The module returns a valid response.

Command: \$016 Response: !013A
Reads the channel status of module 01 and returns a response of 3A, meaning that channels 1, 3, 4, and 5 are enabled and all other channels are disabled.

Related Commands:

Section 2.14 \$AA6

Note:

1. It is recommended that only the channels that will be used are enabled.
2. For I-7017Z, M-7017Z, M-7017mC-16, I-7018Z, M-7018Z and M-7019Z, the command is \$AA5VVVV. The command is \$AA5VVVVVV for I-7017Z and M-7017Z in single-ended mode.

2.14 \$AA6

Description:

Reads the enabled/disabled status of each channel.

Syntax:

\$AA6[CHKSUM](CR)

\$ Delimiter character
AA Address of the module to be read (00 to FF)
6 Command to read the channel status

Response:

Valid Response: **!AAVV(VV)[CHKSUM](CR)**

Invalid Response: **?AA[CHKSUM](CR)**

! Delimiter character for a valid response
? Delimiter character for an invalid response
AA Address of the responding module (00 to FF)
VV(VV) A two-digit hexadecimal value, where bit 0 corresponds to channel 0, bit 1 corresponds to channel 1, etc. When the bit is 1 it means that the channel is enabled and 0 means that the channel is disabled. It is four-digit hexadecimal for I-7017Z, M-7017Z, M-7017mC-16, I-7018Z, M-7018Z and M-7019Z. Note: it is six-digit hexadecimal for I-7017Z and M-7017Z in single-ended mode.

There will be no response if the command syntax is incorrect, there is a communication error, or there is no module with the specified address.

I-7017, I-7018, I-7019 series
M-7017, M-7018, M-7019 series

Examples:

Command: \$0153A Response: !01

Enables channels 1, 3, 4, and 5 and disables all other channels of module 01. The module returns a valid response.

Command: \$016 Response: !013A

Reads the channel status of module 01 and returns a response of 3A, meaning that channels 1, 3, 4, and 5 are enabled and all other channels are disabled.

Related Commands:

Section 2.13 \$AA5VV

Note:

For I-7017Z, M-7017Z, M-7017mC-16, I-7018Z, M-7018Z and M-7019Z, the format of the response is !AAVVVV. It is !AAVVVVVV for I-7017Z and M-7017Z in single-ended mode.

2.15 \$AA7CiRrr

Description:

Sets the type code of a channel.

Syntax:

\$AA7CiRrr[CHKSUM](CR)

| | |
|-----|---|
| \$ | Delimiter character |
| AA | Address of the module to be set (00 to FF) |
| 7 | Command to set the channel range code |
| Ci | i specifies the input channel to be set (0-F for M-7017mC-16, 0-9 for I-7017Z, M-7017Z, I-7018Z, M-7018Z and M-7019Z, 0-7 for I-7017R firmware version B3.9 and later, M-7017R firmware version B3.9 and later, M-7017RMS, I-7018R firmware version B4.2 and later, M-7018R firmware version B4.5 and later, I-7019R and M-7019R). Note: i is a two digits in hex format (00-13) for I-7017Z and M-7017Z in single-ended mode. |
| Rrr | rr represents the type code of the channel to be set. Refer to the Analog Input Type Setting table in Section 1.11 for details. |

Response:

Valid Response: !AA [CHKSUM](CR)

Invalid Response: ?AA[CHKSUM](CR)

! Delimiter character for a valid response

? Delimiter character for an invalid response or invalid type code

There will be no response if the command syntax is incorrect, there is a communication error, or there is no module with the specified address.

Examples:

Command: \$017C0R03 Response: !01
Sets the type code for channel 0 of module 01 to be 03 (-500~+500mV) and the module returns a valid response.

Command: \$027C5R16 Response: !02
Sets the type code for channel 5 of module 02 to be 16 (Type C thermocouple, +0~+2320°C) and the module returns a valid response.

Command: \$037C1R30 Response: ?03
Sets the type code for channel 1 of module 03 to be 30. The module returns an invalid response because the type code is invalid.

Related Commands:

Section 2.16 \$AA8Ci

Related Topics:

Section 1.11 Configuration Tables

**I-7017R, I-7017Z, I-7018R, I-7018Z, I-7019 series, M-7017mC-16
M-7017R, M-7017RMS, M-7017Z, M-7018R, M-7018Z, M-7019 series**

Note:

This command is only applicable to I-7017R firmware version B3.9 and later, M-7017R firmware version B3.9 and later, M-7017RMS, M-7017mC-16, I-7017Z, M-7017Z, I-7018R firmware version B4.2 and later, M-7018R firmware version B4.5 and later, I-7018Z, M-7018Z, I-7019 and M-7019 series modules.

2.16 \$AA8Ci

Description:

Reads the type code information of a channel.

Syntax:

\$AA8Ci[CHKSUM](CR)

\$ Delimiter character
AA Address of the module to be read (00 to FF)
8 Command to read the type code of a channel
Ci Specifies which channel to access for the type code information (i=0-F for M-7017mC-16, i=0-9 for I-7017Z, M-7017Z, I-7018Z, M-7018Z and M-7019Z, i=0-7 for I-7017R, M-7017R, M-7017RMS, I-7018R, M-7018R, I-7019R and M-7019R).

Note: i is a two digits in hex format (00-13) for I-7017Z and M-7017Z in single-ended mode.

Response:

Valid Response: !AACiRrr[CHKSUM](CR)

Invalid Response: ?AA[CHKSUM](CR)

! Delimiter character for a valid response
? Delimiter character for an invalid response or invalid channel
AA Address of the responding module (00 to FF)
Ci Specifies which input channel to access to retrieve the type code information.
Rrr Represents the type code of the specified input channel. Refer to the Analog Input Type Setting table in Section 1.11 for details.

**I-7017R, I-7017Z, I-7018R, I-7018Z, I-7019 series, M-7017mC-16
M-7017R, M-7017RMS, M-7017Z, M-7018R, M-7018Z, M-7019 series**

There will be no response if the command syntax is incorrect, there is a communication error, or there is no module with the specified address.

Examples:

Command: \$018C0 Response: !01C0R02
 Reads the channel 0 input range of module 01 and
 returns 02 (-100~+100mV).

Related Commands:

Section 2.15 \$AA7CiRrr

Related Topics:

Section 1.11 Configuration Tables

Note:

This command is only applicable to I-7017R firmware version B3.9 and later, M-7017R firmware version B3.9 and later, M-7017RMS, M-7017mC-16, I-7017Z, M-7017Z, I-7018R firmware version B4.2 and later, M-7018R firmware version B4.5 and later, I-7018Z, M-7018Z, I-7019 and M-7019 series modules.

2.17 \$AA9

Description:

Reads the CJC (cold junction compensation) offset value that is set by the \$AA9SNNNN command (Section 2.18).

Syntax:

\$AA9[CHKSUM](CR)

\$ Delimiter character
AA Address of the module to be read (00 to FF)
9 Command to read the CJC offset value

Response:

Valid Response: **!AA(Data)[CHKSUM](CR)**

Invalid Response: **?AA[CHKSUM](CR)**

! Delimiter character for a valid response
? Delimiter character for an invalid response
AA Address of the responding module (00 to FF)
(Data) CJC offset value consisting of a sign byte, '+' or
 '-', followed by 4 hexadecimal digits. Each
 count is equal to 0.01°C.

There will be no response if the command syntax is incorrect, there is a communication error, or there is no module with the specified address.

Examples:

Command: \$019

Response: !01+0010

Reads the CJC offset of module 01 and the module responds with +10 which means +0.16°C.

Related Commands:

Section 2.11 \$AA3, Section 2.18 \$AA9SNNNN, Section 2.20 \$AAA, Section 2.21 \$AAAi, Section 2.30 ~AACN

Note:

This command is only applicable to I-7018, M-7018, I-7019 and M-7019 series modules.

2.18 \$AA9SNNNN

Description:

Sets the CJC (cold junction compensation) offset value to adjust the error produced by the CJC sensor.

Syntax:

\$AA9SNNNN[CHKSUM](CR)

| | |
|------|---|
| \$ | Delimiter character |
| AA | Address of the module to be read (00 to FF) |
| 9 | Command to set the CJC offset value |
| S | Sign byte, '+' or '-', of the offset value |
| NNNN | The absolute value of the offset in four hexadecimal digits, which must be less than or equal to 1000h. Each count is equal to 0.01 °C. |

Response:

Valid Response: **!AA[CHKSUM](CR)**

Invalid Response: **?AA[CHKSUM](CR)**

| | |
|----|---|
| ! | Delimiter character for a valid response |
| ? | Delimiter character for an invalid response |
| AA | Address of the responding module (00 to FF) |

There will be no response if the command syntax is incorrect, there is a communication error, or there is no module with the specified address.

Examples:

Command: \$019+0010

Response: !01

Sets the CJC offset of module 01 to +0.16°C and returns a valid response.

Related Commands:

Section 2.11 \$AA3, Section 2.17 \$AA9, Section 2.20 \$AAA, Section 2.21 \$AAAi, Section 2.30 ~AACN

Note:

This command is only applicable to I-7018, M-7018, I-7019 and M-7019 series modules.

2.19 \$AAA

Description:

Reads the data from every analog input channel in hex format.

Syntax:

\$AAA[CHKSUM](CR)

\$ Delimiter character

AA Address of the module to be read (00 to FF)

A Command to read every analog input

Response:

Valid Response: **>(Data)[CHKSUM](CR)**

Invalid Response: **?AA[CHKSUM](CR)**

> Delimiter character for a valid response

? Delimiter character for an invalid response

(Data) Data from every analog input channels in hex format.

There will be no response if the command syntax is incorrect, there is a communication error, or there is no module with the specified address.

I-7017, M-7017 series

Examples:

Command: \$01A

Response: >0000012301257FFF1802744F98238124

Reads module 01 and receives the data in hex format.

Related Commands:

Section 2.3 #AA

Note:

This command is only applicable to I-7017 and M-7017 series modules.

2.20 \$AAA

Description:

Reads the CJC temperature update setting.

Syntax:

\$AAA[CHKSUM](CR)

\$ Delimiter character
AA Address of the module to be read (00 to FF)
A Command to read the CJC temperature update setting

Response:

Valid Response: **!AAi[CHKSUM](CR)**

Invalid Response: **?AA[CHKSUM](CR)**

! Delimiter character for a valid response
? Delimiter character for an invalid response
AA Address of the responding module (00 to FF)
i CJC temperature update setting:
0= CJC temperature update has been stopped.
1= CJC temperature update has been started.
2= Update CJC temperature once only.

There will be no response if the command syntax is incorrect, there is a communication error, or there is no module with the specified address.

Examples:

Command: \$01A

Response: !011

Reads the CJC temperature update setting of module 01 and the module responds with 1, meaning that the CJC temperature update has been started.

Related Commands:

Section 2.11 \$AA3, Section 2.17 \$AA9, Section 2.18 \$AA9SNNNN, Section 2.21 \$AAAi, Section 2.30 ~AACN

Note:

This command is only applicable to I-7019 and M-7019 series modules.

2.21 \$AAAi

Description:

Sets the CJC temperature update setting.

Syntax:

\$AAAi[CHKSUM](CR)

| | |
|----|---|
| \$ | Delimiter character |
| AA | Address of the module to be read (00 to FF) |
| A | Command to set the CJC temperature update setting |
| i | CJC temperature update setting: 0= stop the CJC temperature update 1= start the CJC temperature update (default value) 2= update the CJC temperature only once, after the command is received. |

Response:

Valid Response: **!AA[CHKSUM](CR)**

Invalid Response: **?AA[CHKSUM](CR)**

| | |
|----|---|
| ! | Delimiter character for a valid response |
| ? | Delimiter character for an invalid response |
| AA | Address of the responding module (00 to FF) |

There will be no response if the command syntax is incorrect, there is a communication error, or there is no module with the specified address.

Examples:

Command: \$01A1

Response: !01

Sends a command to start the CJC temperature update of module 01 and returns a valid response.

Related Commands:

Section 2.11 \$AA3, Section 2.17 \$AA9, Section 2.18 \$AA9SNNNN, Section 2.20 \$AAA, Section 2.30 ~AACN

Note:

This command is only applicable to I-7019 and M-7019 series modules.

2.22 \$AAB

Description:

Diagnoses the over-range, under-range, and wire opening status of the analog inputs.

Syntax:

\$AAB[CHKSUM](CR)

\$ Delimiter character

AA Address of the module to be diagnosed (00 to FF)

B Command to diagnose the analog inputs

Response:

Valid Response: !AANN[CHKSUM](CR)

Invalid Response: ?AA[CHKSUM](CR)

! Delimiter character for a valid response

? Delimiter character for an invalid response

AA Address of the responding module (00 to FF)

NN Represents the diagnostic results of every analog input channel (00 to FF), where bit 0 corresponds to channel 0, bit 1 corresponds to channel 1, etc. When the bit is 1, it means that the channel is enabled and it is either over-range, under-range or wire opening. If the bit is 0 it means that the channel is disabled or normal.

There will be no response if the command syntax is incorrect, there is a communication error, or there is no module with the specified address.

Examples:

Command: \$01B

Response: !0101

Diagnoses the analog inputs of module 01. The module returns a valid response and channel 1 is either over-range, under-range or wire opening.

Note:

This command is only applicable to I-7019 and M-7019 series modules.

2.23 \$AAF

Description:

Reads the firmware version of a module.

Syntax:

\$AAF[CHKSUM](CR)

- \$ Delimiter character
- AA Address of the module to be read (00 to FF)
- F Command to read the firmware version

Response:

Valid Response: **!AA(Data)[CHKSUM](CR)**

Invalid Response: **?AA[CHKSUM](CR)**

- ! Delimiter character for a valid response
- ? Delimiter character for an invalid response
- AA Address of the responding module (00 to FF)
- (Data) A string indicating the firmware version of the module

There will be no response if the command syntax is incorrect, there is a communication error, or there is no module with the specified address.

Examples:

Command: \$01F

Response: !01A2.0

Reads the firmware version of module 01, and shows that it is version A2.0.

2.24 \$AAM

Description:

Reads the name of a module.

Syntax:

\$AAM[CHKSUM](CR)

\$ Delimiter character

AA Address of the module to be read (00 to FF)

M Command to read the module name

Response:

Valid Response: !AA(Name)[CHKSUM](CR)

Invalid Response: ?AA[CHKSUM](CR)

! Delimiter character for a valid response

? Delimiter character for an invalid response

AA Address of the responding module (00 to FF)

(Name) A string showing the name of the module

There will be no response if the command syntax is incorrect, there is a communication error, or there is no module with the specified address.

2.25 \$AAP

Description:

Reads the communication protocol information.

Syntax:

\$AAP[CHKSUM](CR)

\$ Delimiter character

AA Address of the module to be read (00 to FF)

P Command to read the communication protocol

Response:

Valid Response: !AASC[CHKSUM](CR)

Invalid Response: ?AA[CHKSUM](CR)

! Delimiter character for a valid response

? Delimiter character for an invalid response

AA Address of the responding module (00 to FF)

S The protocols supported by the module

0: only DCON protocol is supported

1: both the DCON and Modbus RTU protocols
are supported

C Current protocol saved in EEPROM that will be
used at the next power on reset

0: the protocol set in EEPROM is DCON

1: the protocol set in EEPROM is Modbus RTU

There will be no response if the command syntax is incorrect, there is a communication error, or there is no module with the specified address.

Examples:

Command: \$01P

Response: !0110

Reads the communication protocol of module 01 and returns a response of 10 meaning that it supports both the DCON and Modbus RTU protocols and the protocol that will be used at the next power on reset is DCON.

Related Commands:

Section 2.26 \$AAPN

Note:

This command is only applicable to M-7017, M-7018 and M-7019 series modules.

2.26 \$AAPN

Description:

Sets the communication protocol.

Syntax:

\$AAPN[CHKSUM](CR)

\$ Delimiter character

AA Address of the module to be read (00 to FF)

P Command to set the communication protocol

N 0: DCON protocol

1: Modbus RTU protocol

Before using this command, the rear slide switch must be in the INIT position, see Section A.1 for details. The new protocol is saved in the EEPROM and will be effective after the next power on reset.

Response:

Valid Response: !AA[CHKSUM](CR)

Invalid Response: ?AA[CHKSUM](CR)

! Delimiter character for a valid response

? Delimiter character for an invalid response

AA Address of the responding module (00 to FF)

There will be no response if the command syntax is incorrect, there is a communication error, or there is no module with the specified address.

Examples:

Command: \$01P1

Response: ?01

Sets the communication protocol of module 01 to Modbus RTU and returns an invalid response because the module is not in INIT mode.

Command: \$01P1

Response: !01

Sets the communication protocol of module 01 to Modbus RTU and returns a valid response.

Related Commands:

Section 2.25 \$AAP

Related Topics:

Section A.1 INIT Mode

Note:

This command is only applicable to M-7017, M-7018 and M-7019 series modules.

2.27 \$AAS0

Description:

Performs an internal calibration on a module.

Syntax:

\$AAS0[CHKSUM](CR)

\$ Delimiter character

AA Address of module to be calibrated (00 to FF)

S0 Command to perform the internal calibration

Response:

Valid Response: **!AA[CHKSUM](CR)**

Invalid Response: **?AA[CHKSUM](CR)**

! Delimiter character for a valid response

? Delimiter character for an invalid response

AA Address of the responding module (00 to FF)

There will be no response if the command syntax is incorrect, there is a communication error, or there is no module with the specified address.

Examples:

Command: \$01S0

Response: !01

Sends the command to perform an internal calibration on module 01 and returns a valid response.

Related Commands:

Section 2.28 \$AAS1

Note:

This command is only applicable to I-7019 and M-7019 series modules.

2.28 \$AAS1

Description:

Reloads the factory default calibration parameters, including the internal calibration parameters.

Syntax:

\$AAS1[CHKSUM](CR)

\$ Delimiter character
AA Address of the module to be reloaded (00 to FF)
S1 Command to reload the factory default
 calibration parameters

Response:

Valid Response: **!AA[CHKSUM](CR)**
Invalid Response: **?AA[CHKSUM](CR)**
! Delimiter character for a valid response
? Delimiter character for an invalid response
AA Address of the responding module (00 to FF)

There will be no response if the command syntax is incorrect, there is a communication error, or there is no module with the specified address.

Examples:

Command: \$01S1 Response: !01
 Sends the command to reload the factory default
 calibration parameters and returns a valid response.

Related Commands:

Section 2.27 \$AAS0

Related Topics:

Section 1.10 Calibration

Note:

1. This command is only applicable to M-7017mC-16, I-7019 and M-7019 series modules.
2. This command takes about three seconds for firmware version B2.7 and later.

2.29 ~AAC

Description:

Reads the CJC (cold junction compensation) enabled/disabled status.

Syntax:

~AAC[CHKSUM](CR)

~ Delimiter character
AA Address of the module to be read (00 to FF)
C Command to read the CJC enabled/disabled status

Response:

Valid Response: **!AAN[CHKSUM](CR)**

Invalid Response: **?AA[CHKSUM](CR)**

! Delimiter character for a valid response
? Delimiter character for an invalid response
AA Address of the responding module (00 to FF)
N 0: CJC disabled
1: CJC enabled

There will be no response if the command syntax is incorrect, there is a communication error, or there is no module with the specified address.

Examples:

Command: ~01C

Response: !011

Sends a command to read the CJC enabled/disabled status of module 01 and shows that the CJC is enabled.

Related Commands:

Section 2.11 \$AA3, Section 2.17 \$AA9, Section 2.18 \$AA9SNNNN, Section 2.20 \$AAA, Section 2.21 \$AAAi, Section 2.30 ~AACN

Note:

This command is only applicable to I-7018, M-7018, I-7019 and M-7019 series modules.

2.30 ~AACN

Description:

Enable/disable CJC (cold junction compensation).

Syntax:

~AACN[CHKSUM](CR)

- ~ Delimiter character
- AA Address of the module to be read (00 to FF)
- C Command to enable/disable CJC
- N 0: disable CJC
1: enable CJC

Response:

Valid Response: **!AA[CHKSUM](CR)**

Invalid Response: **?AA[CHKSUM](CR)**

- ! Delimiter character for a valid response
- ? Delimiter character for an invalid response
- AA Address of the responding module (00 to FF)

There will be no response if the command syntax is incorrect, there is a communication error, or there is no module with the specified address.

Examples:

Command: ~01C0

Response: !01

Sends a command to disable CJC of module 01 and returns a valid response.

Related Commands:

Section 2.11 \$AA3, Section 2.17 \$AA9, Section 2.18 \$AA9SNNNN, Section 2.20 \$AAA, Section 2.21 \$AAAi, Section 2.29 ~AAC

Notes:

This command is only applicable to I-7018, M-7018, I-7019 and M-7019 series modules.

2.31 ~AAEV

Description:

Enable/Disable module calibration.

Syntax:

~AAEV[CHKSUM](CR)

- ~ Delimiter character
- AA Address of the module to be set (00 to FF)
- E Command to enable/disable calibration
- V 1: enable calibration
0: disable calibration

Response:

Valid Response: **!AA[CHKSUM](CR)**

Invalid Response: **?AA[CHKSUM](CR)**

- ! Delimiter character for a valid response
- ? Delimiter character for an invalid response
- AA Address of the responding module (00 to FF)

There will be no response if the command syntax is incorrect, there is a communication error, or there is no module with the specified address.

Examples:

Command: \$010

Response: ?01

Sends the command to perform a span calibration on module 01. It returns an invalid response because the “enable calibration” command was not sent in advance.

Command: ~01E1

Response: !01

Enables calibration on module 01 and returns a valid response.

Command: \$010

Response: !01

Sends the command to perform a span calibration on module 01 and returns a valid response.

Related Commands:

Section 2.5 \$AA0, Section 2.6 \$AA1, Section 2.8 \$AA0Ci,
Section 2.9 \$AA1Ci

Related Topics:

Section 1.10 Calibration

2.32 ~AAI

Description:

The Soft INIT command is used to enable modification of the Baud Rate and checksum settings using software only.

Syntax:

~AAI[CHKSUM](CR)

~ Delimiter character

AA Address of the module to be set (00 to FF)

I Command to set the Soft INIT

Response:

Valid Response: **!AA[CHKSUM](CR)**

Invalid Response: **?AA[CHKSUM](CR)**

! Delimiter character for a valid response

? Delimiter character for an invalid response

AA Address of the responding module (00 to FF)

There will be no response if the command syntax is incorrect, there is a communication error, or there is no module with the specified address.

Examples:

Command: ~01I

Response: !01

Sets the soft INIT of module 01 and returns a valid response.

Related Commands:

Section 2.1 %AANNTTCCFF, Section 2.34 ~AATnn

Related Topics:

Section A.1 INIT Mode

Notes:

1. This command is only applicable to M-7017mC-16, I-7019 and M-7019 series modules.
2. The ~AATnn command should be sent prior to sending this command, see Section 2.34 for details.

2.33 ~AAO(Name)

Description:

Sets the name of a module.

Syntax:

~AAO(Name)[CHKSUM](CR)

~ Delimiter character

AA Address of the module to be set (00 to FF)

O Command to set the module name

(Name) New name of the module (max. 6 characters).

Response:

Valid Response: **!AA[CHKSUM](CR)**

Invalid Response: **?AA[CHKSUM](CR)**

! Delimiter character for a valid response

? Delimiter character for an invalid response

AA Address of the responding module (00 to FF)

There will be no response if the command syntax is incorrect, there is a communication error, or there is no module with the specified address.

I-7017, I-7018, I-7019 series
M-7017, M-7018, M-7019 series

Examples:

Command: ~01O7019A Response: !01
 Sets the name of module 01 to be “7019A” and
 returns a valid response.

Command: \$01M Response: !017019A
 Reads the name of module 01 and returns “7019A”.

Related Commands:

Section 2.24 \$AAM

2.34 ~AATnn

Description:

Sets the soft INIT time out value.

Syntax:

~AATnn[CHKSUM](CR)

~ Delimiter character
AA Address of the module to be set (00 to FF)
T Command to set the soft INIT time out value
nn Two hexadecimal digits representing the time out value in seconds. The max time out value is 60 seconds. When changing the Baud Rate or checksum settings without altering the INIT* pin, the ~AAI and %AANNTTCCFF commands should be sent consecutively and the time interval between the two commands should be less than the soft INIT time out. If the soft INIT time out is 0, then the Baud Rate and checksum settings cannot be changed using software only. The power on reset value of the soft INIT time out is 0.

Response:

Valid Response: **!AA[CHKSUM](CR)**

Invalid Response: **?AA[CHKSUM](CR)**

! Delimiter character for a valid response

? Delimiter character for an invalid response

AA Address of the responding module (00 to FF)

There will be no response if the command syntax is incorrect, there is a communication error, or there is no module with the specified address.

Examples:

Command: ~01I

Response: !01

Sets the soft INIT of module 01 and returns a valid response.

Command: %0101000700

Response: ?01

Attempts to change the Baud Rate of module 01 to 19200 without first altering the INIT * pin. The module returns an invalid response because the soft INIT time out value is 0.

Command: ~01T10

Response: !01

Sets the soft INIT time out value of module 01 to 16 seconds and returns a valid response.

Command: ~01I

Response: !01

Sets the soft INIT of module 01 and returns a valid response.

Command: %0101000700

Response: !01

Changes the Baud Rate of module 01 to 19200 without first altering INIT * pin. The module returns a valid response.

Related Commands:

Section 2.1 %AANNTTCCFF, Section 2.32 ~AAI

Related Topics:

Section A.1 INIT Mode

Notes:

1. This command is only applicable to M-7017mC-16, I-7019 and M-7019 series modules.
2. It is recommended that the soft INIT time out value is reset to 0 once any changes to Baud Rate and checksum settings have been completed.

2.35 ~**

Description:

Informs all modules that the host is OK.

Syntax:

~**[CHKSUM](CR)

~ Delimiter character

** Host OK command

Response:

No response.

Examples:

Command: ~** No response
Sends a “Host OK” command to all modules.

Related Commands:

Section 2.36 ~AA0, Section 2.37 ~AA1, Section 2.38
~AA2, Section 2.39 ~AA3Evv

Related Topics:

Section A.2 Dual Watchdog Operation

Note:

After sending this command, there must be a 2ms delay before the next command can be sent.

2.36 ~AA0

Description:

Reads the host watchdog status of a module.

Syntax:

~AA0[CHKSUM](CR)

- ~ Delimiter character
- AA Address of the module to be read (00 to FF)
- 0 Command to read the module status

Response:

Valid Response: !AASS[CHKSUM](CR)

Invalid Response: ?AA[CHKSUM](CR)

- ! Delimiter character for a valid response
- ? Delimiter character for an invalid response
- AA Address of the responding module (00 to FF)
- SS Two hexadecimal digits that represent the host watchdog status, where:
 - Bit 7: 0 indicates that the host watchdog is disabled and 1 indicates the host watchdog is enabled,
 - Bit 2: 1 indicates that a host watchdog time out has occurred and 0 indicates that no host watchdog time out has occurred.The host watchdog status is stored in EEPROM and can only be reset using the ~AA1 command.

I-7017, I-7018, I-7019 series
M-7017, M-7018, M-7019 series

There will be no response if the command syntax is incorrect, there is a communication error, or there is no module with the specified address.

Examples:

| | |
|--|-----------------|
| Command: ~010 | Response: !0100 |
| Reads the host watchdog status of module 01 and returns 00, meaning that the host watchdog is disabled and no host watchdog time out has occurred. | |
| Command: ~020 | Response: !0204 |
| Reads the host watchdog status of module 02 and returns 04, meaning that a host watchdog timeout has occurred. | |

Related Commands:

Section 2.35 ~**, Section 2.37 ~AA1, Section 2.38 ~AA2, Section 2.39 ~AA3Evv

Related Topics:

Section A.2 Dual Watchdog Operation

2.37 ~AA1

Description:

Resets the host watchdog time out status of a module.

Syntax:

~AA1[CHKSUM](CR)

- ~ Delimiter character
- AA Address of the module to be set (00 to FF)
- 1 Command to reset the host watchdog time out status

Response:

Valid Response: **!AA[CHKSUM](CR)**

Invalid Response: **?AA[CHKSUM](CR)**

- ! Delimiter character for a valid response
- ? Delimiter character for an invalid response
- AA Address of the responding module (00 to FF)

There will be no response if the command syntax is incorrect, there is a communication error, or there is no module with the specified address.

Examples:

Command: ~010

Response: !0104

Reads the host watchdog status of module 01 and shows that a host watchdog time out has occurred.

Command: ~011

Response: !01

Resets the host watchdog time out status of module 01 and returns a valid response.

Command: ~010

Response: !0100

Reads the host watchdog status of module 01 and shows that no host watchdog time out has occurred.

Related Commands:

Section 2.35 ~**, Section 2.36 ~AA0, Section 2.38 ~AA2, Section 2.39 ~AA3EVV

Related Topics:

Section A.2 Dual Watchdog Operation

2.38 ~AA2

Description:

Reads the host watchdog time out value of a module.

Syntax:

~AA2[CHKSUM](CR)

- ~ Delimiter character
- AA Address of the module to be read (00 to FF)
- 2 Command to read the host watchdog time out value

Response:

Valid Response: !AAEVV[CHKSUM](CR)

Invalid Response: ?AA[CHKSUM](CR)

- ! Delimiter character for a valid response
- ? Delimiter character for an invalid response
- AA Address of the responding module (00 to FF)
- E 1: the host watchdog is enabled
0: the host watchdog is disabled
- VV Two hexadecimal digits to represent the time out value in tenths of a second, for example, 01 means 0.1 seconds and FF means 25.5 seconds.

There will be no response if the command syntax is incorrect, there is a communication error, or there is no module with the specified address.

I-7017, I-7018, I-7019 series
M-7017, M-7018, M-7019 series

Examples:

Command: ~012

Response: !011FF

Reads the host watchdog time out value of module 01 and returns FF, meaning that the host watchdog is enabled and the host watchdog time out value is 25.5 seconds.

Related Commands:

Section 2.35 ~**, Section 2.36 ~AA0, Section 2.37 ~AA1,
Section 2.39 ~AA3EVV

Related Topics:

Section A.2 Dual Watchdog Operation

2.39 ~AA3E VV

Description:

Enables/disables the host watchdog and set the host watchdog time out value of a module.

Syntax:

~AA3E VV[CHKSUM](CR)

- ~ Delimiter character
- AA Address of the module to be set (00 to FF)
- 3 Command to set the host watchdog
- E 1: enable the host watchdog
0: disable the host watchdog
- VV Two hexadecimal digits to represent the time out value in tenths of a second, for example, 01 means 0.1 seconds and FF means 25.5 seconds.

Response:

Valid Response: !AA[CHKSUM](CR)

Invalid Response: ?AA[CHKSUM](CR)

- ! Delimiter character for a valid response
- ? Delimiter character for an invalid response
- AA Address of the responding module (00 to FF)

There will be no response if the command syntax is incorrect, there is a communication error, or there is no module with the specified address.

I-7017, I-7018, I-7019 series
M-7017, M-7018, M-7019 series

Examples:

Command: ~013164

Response: !01

Enables the host watchdog of module 01 and sets the host watchdog time out value to 10.0 seconds.

The module returns a valid response.

Command: ~012

Response: !01164

Reads the host watchdog time out value of module 01. The module returns 164, meaning that the host watchdog is enabled and the host watchdog time out value is 10.0 seconds.

Related Commands:

Section 2.35 ~**, Section 2.36 ~AA0, Section 2.37 ~AA1,
Section 2.38 ~AA2

Related Topics:

Section A.2 Dual Watchdog Operation

2.40 ~AAEO

Description:

Reads the open wire detection enabled/disabled status.

Syntax:

~AAEE[CHKSUM](CR)

- ~ Delimiter character
- AA Address of the module to be read (00 to FF)
- EO Command to read the open wire detection enabled/disabled status

Response:

Valid Response: **!AAN[CHKSUM](CR)**

Invalid Response: **?AA[CHKSUM](CR)**

- ! Delimiter character for a valid response
- ? Delimiter character for an invalid response
- AA Address of the responding module (00 to FF)
- N 0: open wire detection disabled
1: open wire detection enabled

There will be no response if the command syntax is incorrect, there is a communication error, or there is no module with the specified address.

I-7018R, M-7018R
I-7019, M-7019 series

Examples:

Command: ~01EO

Response: !011

Sends a command to read the open wire detection enabled/disabled status of module 01 and shows that the open wire detection is enabled.

Related Commands:

Section 2.41 ~AAEON

Note:

This command is only applicable to I-7018R and M-7018R modules firmware version B4.2 and later, and I-7019 and M-7019 series modules firmware version B3.7 and later.

2.41 ~AAEON

Description:

Enable/disable open wire detection.

Syntax:

~AAEEN[CHKSUM](CR)

~ Delimiter character

AA Address of the module to be read (00 to FF)

EO Command to enable/disable open wire detection

N 0: disable open wire detection

1: enable open wire detection

Response:

Valid Response: **!AA[CHKSUM](CR)**

Invalid Response: **?AA[CHKSUM](CR)**

! Delimiter character for a valid response

? Delimiter character for an invalid response

AA Address of the responding module (00 to FF)

There will be no response if the command syntax is incorrect, there is a communication error, or there is no module with the specified address.

I-7018R, M-7018R
I-7019, M-7019 series

Examples:

Command: ~01EO0

Response: !01

Sends a command to disable open wire detection of module 01 and returns a valid response.

Related Commands:

Section 2.40 ~AAEO

Notes:

This command is only applicable to I-7018R and M-7018R modules firmware version B4.2 and later, and I-7019 and M-7019 series modules firmware version B3.7 and later.

2.42 @AAS

Description:

Reads the differential/single-ended connecting mode status.

Syntax:

@AAS[CHKSUM](CR)

@ Delimiter character
AA Address of the module to be read (00 to FF)
S Command to read the connecting mode

Response:

Valid Response: !AAN[CHKSUM](CR)

Invalid Response: ?AA[CHKSUM](CR)

! Delimiter character for a valid response
? Delimiter character for an invalid response
AA Address of the responding module (00 to FF)
N Current connecting mode
 0: differential mode
 1: single-ended mode

There will be no response if the command syntax is incorrect, there is a communication error, or there is no module with the specified address.

Examples:

Command: @01S

Response: !010

Reads the connecting mode of module 01 and returns a response of 0 meaning that it is in differential mode.

Related Commands:

Section 2.43 @AASN

Note:

This command is only applicable to I-7017Z and M-7017Z modules.

2.43 @AASN

Description:

Sets the connecting mode to differential or single-ended.

Syntax:

@AAPN[CHKSUM](CR)

| | |
|----|---|
| @ | Delimiter character |
| AA | Address of the module to be read (00 to FF) |
| S | Command to set the connecting mode |
| N | 0: differential 1: single-ended |

Response:

Valid Response: !AA[CHKSUM](CR)

Invalid Response: ?AA[CHKSUM](CR)

| | |
|----|---|
| ! | Delimiter character for a valid response |
| ? | Delimiter character for an invalid response |
| AA | Address of the responding module (00 to FF) |

There will be no response if the command syntax is incorrect, there is a communication error, or there is no module with the specified address.

Examples:

Command: @01S1

Response: !01

Sets the connecting mode of module 01 to single-ended.

Related Commands:

Section 2.42 @AAS

Note:

This command is only applicable to I-7017Z and M-7017Z modules.

3. Modbus RTU Protocol

The Modbus protocol is developed by Modicon Inc., originally developed for Modicon controllers. Detailed information can be found at <http://www.modicon.com/techpubs/toc7.html>. You can also visit <http://www.modbus.org> to find more valuable information.

M-7000 series modules support the Modbus RTU protocol. The communication Baud Rates range from 1200bps to 115200bps. The parity, data bits and stop bits are fixed as no parity, 8 data bits and 1 stop bit. The following Modbus functions are supported.

| Function Code | Description | Section |
|---------------|----------------------------|---------|
| 02 (0x02) | Read input status | 3.1 |
| 04 (0x04) | Read input channels | 3.2 |
| 70 (0x46) | Read/write module settings | 3.3 |

Note: Function 02 is used to read the thermocouple wire opening status and is only supported by M-7019 series modules.

If the function specified in the message is not supported, then the module responds as follows.

Error Response

| | | | |
|----|----------------|--------|----------------------|
| 00 | Address | 1 Byte | 1 to 247 |
| 01 | Function code | 1 Byte | Function code 0x80 |
| 02 | Exception code | 1 Byte | 01 |

If a CRC mismatch occurs, the module will not respond.

3.1 02 (0x02) Read Input Status

This function code is used to read the thermocouple wire opening status of a module.

Request

| | | | |
|---------|--------------------------|---------|--|
| 00 | Address | 1 Byte | 1 to 247 |
| 01 | Function code | 1 Byte | 0x02 |
| 02 ~ 03 | Starting channel | 2 Bytes | 0x80 to 0x87 (0x89 for M-7019Z), where 0x80 corresponds to channel 0, 0x81 corresponds to channel 1, etc |
| 04 ~ 05 | Number of input channels | 2 Bytes | N, 1 to 8 (10 for M-7019Z); (Starting channel + N) should be less than or equal to 0x88 (0x8A for M-7019Z) |

Note: This function is only available on M-7019 series modules.

Response

| | | | |
|----|------------------------|--------|--|
| 00 | Address | 1 Byte | 1 to 247 |
| 01 | Function code | 1 Byte | 0x02 |
| 02 | Byte count | 1 Byte | 1 |
| 03 | Data of input channels | 1 Byte | A bit corresponds to a channel. When the bit is 1 it denotes that the channel is enabled and is either over-range, under-range or wire opening. If the bit is 0 it denotes that the channel is disabled or normal. |

Error Response

| | | | |
|----|----------------|--------|---|
| 00 | Address | 1 Byte | 1 to 247 |
| 01 | Function code | 1 Byte | 0x82 |
| 02 | Exception code | 1 Byte | 02: starting channel out of range 03: (starting channel + number of input channels) out of range, incorrect number of bytes received |

3.2 04 (0x04) Read Input Channels

This function code is used to read from contiguous analog input channels or the CJC temperature.

Request

| | | | |
|---------|------------------------------|---------|--|
| 00 | Address | 1 Byte | 1 to 247 |
| 01 | Function code | 1 Byte | 0x04 |
| 02 ~ 03 | Starting channel | 2 Bytes | 0 to 7 (9 for M-7017Z, M-7018Z and M-7019Z) for reading analog inputs 0x80 for reading CJC temperature |
| 04 ~ 05 | Number of input channels (N) | 2 Bytes | 1 to 8 (10 for M-7017Z, M-7018Z and M-7019Z); (Starting channel + N) <= 8 (10 for M-7017Z, M-7018Z and M-7019Z) for reading analog inputs. 1 for reading CJC temperature. |

Note: The CJC temperature is only available on M-7018 and M-7019 series modules.

Response

| | | | |
|------|------------------------|-------------|--|
| 00 | Address | 1 Byte | 1 to 247 |
| 01 | Function code | 1 Byte | 0x04 |
| 02 | Byte count | 1 Byte | 2 x N |
| 03 ~ | Data of input channels | 2 x N Bytes | When used for the CJC temperature, this is a 2's complement hex value in 0.01 °C increments. |

Error Response

| | | | |
|----|----------------|--------|---|
| 00 | Address | 1 Byte | 1 to 247 |
| 01 | Function code | 1 Byte | 0x84 |
| 02 | Exception code | 1 Byte | 02: starting channel out of range 03: (starting channel + number of input channels) out of range, incorrect number of bytes received |

3.3 70 (0x46) Read/Write Module Settings

This function code is used to read the settings of the module or change the settings of the module. The following sub-function codes are supported.

| Sub-function Code | Description | Section |
|-------------------|--|---------|
| 00 (0x00) | Read the module name | 3.3.1 |
| 04 (0x04) | Set the module address | 3.3.2 |
| 05 (0x05) | Read the communication settings | 3.3.3 |
| 06 (0x06) | Set the communication settings | 3.3.4 |
| 07 (0x07) | Read the type code | 3.3.5 |
| 08 (0x08) | Set the type code | 3.3.6 |
| 32 (0x20) | Read the firmware version | 3.3.7 |
| 37 (0x25) | Read the channel enable/disable status | 3.3.8 |
| 38 (0x26) | Set the channel enable/disable | 3.3.9 |
| 41 (0x29) | Read the miscellaneous settings | 3.3.10 |
| 42 (0x2A) | Write the miscellaneous settings | 3.3.11 |
| 43 (0x2B) | Read the CJC offset | 3.3.12 |
| 44 (0x2C) | Write the CJC offset | 3.3.13 |
| 45 (0x2D) | Read the CJC enable/disable status | 3.3.14 |
| 46 (0x2E) | Set the CJC enable/disable | 3.3.15 |
| 47 (0x2F) | Read the CJC update setting | 3.3.16 |
| 48 (0x30) | Write the CJC update setting | 3.3.17 |

If the module does not support the sub-function code specified in the message, then it responds as follows.

Error Response

| | | | |
|----|----------------|--------|-------------------------------|
| 00 | Address | 1 Byte | 1 to 247 |
| 01 | Function code | 1 Byte | 0xC6 |
| 02 | Exception code | 1 Byte | 02: invalid sub-function code |

3.3.1 Sub-function 00 (0x00) Read module name

This sub-function code is used to read the name of a module.

Request

| | | | |
|----|-------------------|--------|----------|
| 00 | Address | 1 Byte | 1 to 247 |
| 01 | Function code | 1 Byte | 0x46 |
| 02 | Sub function code | 1 Byte | 0x00 |

Response

| | | | |
|---------|-------------------|---------|---|
| 00 | Address | 1 Byte | 1 to 247 |
| 01 | Function code | 1 Byte | 0x46 |
| 02 | Sub function code | 1 Byte | 0x00 |
| 03 ~ 06 | Module name | 4 Bytes | 0x00 0x70 0x17 0x00 for M-7017 series modules 0x00 0x70 0x18 0x00 for M-7018 series modules 0x00 0x70 0x19 0x00 for M-7019 series modules |

Error Response

| | | | |
|----|----------------|--------|--|
| 00 | Address | 1 Byte | 1 to 247 |
| 01 | Function code | 1 Byte | 0xC6 |
| 02 | Exception code | 1 Byte | 03: incorrect number of bytes received |

3.3.2 Sub-function 04 (0x04) Set module address

This sub-function code is used to set the address of a module.

Request

| | | | |
|---------|-------------------|---------|----------------|
| 00 | Address | 1 Byte | 1 to 247 |
| 01 | Function code | 1 Byte | 0x46 |
| 02 | Sub function code | 1 Byte | 0x04 |
| 03 | New address | 1 Byte | 1 to 247 |
| 04 ~ 06 | Reserved | 3 Bytes | 0x00 0x00 0x00 |

Response

| | | | |
|---------|--------------------|---------|-------------------------|
| 00 | Address | 1 Byte | 1 to 247 |
| 01 | Function code | 1 Byte | 0x46 |
| 02 | Sub function code | 1 Byte | 0x04 |
| 03 | Set address result | 1 Byte | 0: OK, others: error |
| 04 ~ 06 | Reserved | 3 Bytes | 0x00 0x00 0x00 |

Error Response

| | | | |
|----|----------------|--------|--|
| 00 | Address | 1 Byte | 1 to 247 |
| 01 | Function code | 1 Byte | 0xC6 |
| 02 | Exception code | 1 Byte | 03: new address out of range, reserved bytes should be filled with zero, incorrect number of bytes received |

3.3.3 Sub-function 05 (0x05) Read communication settings

This sub-function code is used to read the communication protocol settings of a module.

Request

| | | | |
|----|-------------------|--------|----------|
| 00 | Address | 1 Byte | 1 to 247 |
| 01 | Function code | 1 Byte | 0x46 |
| 02 | Sub function code | 1 Byte | 0x05 |
| 03 | Reserved | 1 Byte | 0x00 |

Response

| | | | |
|---------|-------------------|---------|---|
| 00 | Address | 1 Byte | 1 to 247 |
| 01 | Function code | 1 Byte | 0x46 |
| 02 | Sub function code | 1 Byte | 0x05 |
| 03 | Reserved | 1 Byte | 0x00 |
| 04 | Baud Rate | 1 Byte | Baud Rate code, see Section 1.11 for details. |
| 05 ~ 07 | Reserved | 3 Bytes | 0x00 0x00 0x00 |
| 08 | Mode | 1 Byte | 0: DCON protocol 1: Modubs RTU protocol |
| 09 ~ 10 | Reserved | 2 Bytes | 0x00 0x00 |

Note: This information is the data saved in the EEPROM and will be used for the next power-on reset. It is not the currently used settings.

Error Response

| | | | |
|----|----------------|--------|--|
| 00 | Address | 1 Byte | 1 to 247 |
| 01 | Function code | 1 Byte | 0xC6 |
| 02 | Exception code | 1 Byte | 03: reserved byte should be filled with zero, incorrect number of bytes received |

3.3.4 Sub-function 06 (0x06) Set communication settings

This sub-function code is used to set the communication protocol of a module.

Request

| | | | |
|---------|-------------------|---------|---|
| 00 | Address | 1 Byte | 1 to 247 |
| 01 | Function code | 1 Byte | 0x46 |
| 02 | Sub function code | 1 Byte | 0x06 |
| 03 | Reserved | 1 Byte | 0x00 |
| 04 | Baud Rate | 1 Byte | Baud Rate code, see Section 1.11 for details. |
| 05 ~ 07 | Reserved | 3 Bytes | 0x00 0x00 0x00 |
| 08 | Mode | 1 Byte | 0: DCON protocol 1: Modubs RTU protocol |
| 09 ~ 10 | Reserved | 2 Bytes | 0x00 0x00 |

Response

| | | | |
|---------|-------------------|---------|----------------------|
| 00 | Address | 1 Byte | 1 to 247 |
| 01 | Function code | 1 Byte | 0x46 |
| 02 | Sub function code | 1 Byte | 0x06 |
| 03 | Reserved | 1 Byte | 0x00 |
| 04 | Baud Rate | 1 Byte | 0: OK, others: error |
| 05 ~ 07 | Reserved | 3 Bytes | 0x00 0x00 0x00 |
| 08 | Mode | 1 Byte | 0: OK, others: error |
| 09 ~ 10 | Reserved | 2 Bytes | 0x00 0x00 |

Note: The new Baud Rate and protocol will be effective after the next power-on reset.

Error Response

| | | | |
|----|----------------|--------|---|
| 00 | Address | 1 Byte | 1 to 247 |
| 01 | Function code | 1 Byte | 0xC6 |
| 02 | Exception code | 1 Byte | 03: Baud Rate or mode out of range, reserved bytes should be filled with zero, incorrect number of bytes received |

3.3.5 Sub-function 07 (0x07) Read type code

This sub-function code is used to read the type code information of a module.

Request

| | | | |
|----|-------------------|---------|--|
| 00 | Address | 1 Byte | 1 to 247 |
| 01 | Function code | 1 Byte | 0x46 |
| 02 | Sub function code | 1 Byte | 0x07 |
| 03 | Reserved | 1 Bytes | 0x00 |
| 04 | Channel | 1 Byte | 0x00 ~ 0x07 for M-7019R 0x00 for M-7017 and M-7018 series modules 0x00 ~ 0x09 for M-7017Z, M-7018Z and M-7019Z |

Response

| | | | |
|----|-------------------|--------|--|
| 00 | Address | 1 Byte | 1 to 247 |
| 01 | Function code | 1 Byte | 0x46 |
| 02 | Sub function code | 1 Byte | 0x07 |
| 03 | Type code | 1 Byte | Type code, see Section 1.11 for details. |

Error Response

| | | | |
|----|----------------|--------|--|
| 00 | Address | 1 Byte | 1 to 247 |
| 01 | Function code | 1 Byte | 0xC6 |
| 02 | Exception code | 1 Byte | 03: reserved bytes should be filled with zero, channel out of range for M-7017Z, M-7018Z and M-7019 series modules, incorrect number of bytes received |

3.3.6 Sub-function 08 (0x08) Set type code

This sub-function code is used to set the type code of a module.

Request

| | | | |
|----|-------------------|--------|--|
| 00 | Address | 1 Byte | 1 to 247 |
| 01 | Function code | 1 Byte | 0x46 |
| 02 | Sub function code | 1 Byte | 0x08 |
| 03 | Reserved | 1 Byte | 0x00 |
| 04 | Channel | 1 Byte | 0x00 ~ 0x07 for M-7019R 0x00 for M-7017 and M-7018 series modules 0x00 ~ 0x09 for M-7017Z, M-7018Z and M-7019Z |
| 05 | Type code | 1 Byte | Type code, see Section 1.11 for details. |

Response

| | | | |
|----|-------------------|--------|------------------------|
| 00 | Address | 1 Byte | 1 to 247 |
| 01 | Function code | 1 Byte | 0x46 |
| 02 | Sub function code | 1 Byte | 0x08 |
| 03 | Type code | 1 Byte | 0: OK others: error |

Error Response

| | | | |
|----|----------------|--------|---|
| 00 | Address | 1 Byte | 1 to 247 |
| 01 | Function code | 1 Byte | 0xC6 |
| 02 | Exception code | 1 Byte | 03: type code out of range, channel out of range for M-7017Z and M-7018Z and M-7019 series modules, reserved bytes should be filled with zero, incorrect number of bytes received |

3.3.7 Sub-function 32 (0x20) Read firmware version

This sub-function code is used to read the firmware version information of a module.

Request

| | | | |
|----|-------------------|--------|----------|
| 00 | Address | 1 Byte | 1 to 247 |
| 01 | Function code | 1 Byte | 0x46 |
| 02 | Sub function code | 1 Byte | 0x20 |

Response

| | | | |
|----|-------------------|--------|-------------|
| 00 | Address | 1 Byte | 1 to 247 |
| 01 | Function code | 1 Byte | 0x46 |
| 02 | Sub function code | 1 Byte | 0x20 |
| 03 | Major version | 1 Byte | 0x00 ~ 0xFF |
| 04 | Minor version | 1 Byte | 0x00 ~ 0xFF |
| 05 | Build version | 1 Byte | 0x00 ~ 0xFF |

Error Response

| | | | |
|----|----------------|--------|--|
| 00 | Address | 1 Byte | 1 to 247 |
| 01 | Function code | 1 Byte | 0xC6 |
| 02 | Exception code | 1 Byte | 03: incorrect number of bytes received |

3.3.8 Sub-function 37 (0x25) Read channel enabled/disabled status

This sub-function code is used to read the enabled/disabled status of each channel in a module.

Request

| | | | |
|----|-------------------|--------|----------|
| 00 | Address | 1 Byte | 1 to 247 |
| 01 | Function code | 1 Byte | 0x46 |
| 02 | Sub function code | 1 Byte | 0x25 |

Response

| | | | |
|----|-------------------------|----------------------|--|
| 00 | Address | 1 Byte | 1 to 247 |
| 01 | Function code | 1 Byte | 0x46 |
| 02 | Sub function code | 1 Byte | 0x25 |
| 03 | Enabled/disabled status | 1 Byte/2 Byte/3 Byte | 0x00 ~ 0xFF, enabled/disabled status of each channel, where bit 0 corresponds to channel 0, bit 1 corresponds to channel 1, etc. When the bit is 1 it denotes that the channel is enabled and 0 denotes that the channel is disabled. 0x0000 ~ 0x03FF for M-7017Z, M-7018Z and M-7019Z 0x000000 ~ 0x0FFFFFF for M-7017Z in single-ended mode |

Error Response

| | | | |
|----|----------------|--------|--|
| 00 | Address | 1 Byte | 1 to 247 |
| 01 | Function code | 1 Byte | 0xC6 |
| 02 | Exception code | 1 Byte | 03: incorrect number of bytes received |

3.3.9 Sub-function 38 (0x26) Set channel enable/disable

This sub-function code is used to specify the channels to be enabled in a module.

Request

| | | | |
|----|------------------------|-----------------------------|--|
| 00 | Address | 1 Byte | 1 to 247 |
| 01 | Function code | 1 Byte | 0x46 |
| 02 | Sub function code | 1 Byte | 0x26 |
| 03 | Enable/disable setting | 1 Byte/ 2 Byte/3 Byte | 0x00 ~ 0xFF, enable/disable setting of each channel, where bit 0 corresponds to channel 0, bit 1 corresponds to channel 1, etc. When the bit is 1 it denotes that the channel is enabled and 0 denotes that the channel is disabled. 0x0000 ~ 0x03FF for M-7017Z, M-7018Z and M-7019Z 0x000000 ~ 0x0FFFFFFF for M-7017Z in single-ended mode |

Response

| | | | |
|----|------------------------|--------|-------------------------|
| 00 | Address | 1 Byte | 1 to 247 |
| 01 | Function code | 1 Byte | 0x46 |
| 02 | Sub function code | 1 Byte | 0x26 |
| 03 | Enable/disable setting | 1 Byte | 0: OK others: error. |

Error Response

| | | | |
|----|----------------|--------|---|
| 00 | Address | 1 Byte | 1 to 247 |
| 01 | Function code | 1 Byte | 0xC6 |
| 02 | Exception code | 1 Byte | 03: enable/disable setting out of range, incorrect number of bytes received |

3.3.10 Sub-function 41 (0x29) Read miscellaneous settings

This sub-function code is used to read the miscellaneous settings of a module.

Request

| | | | |
|----|-------------------|--------|----------|
| 00 | Address | 1 Byte | 1 to 247 |
| 01 | Function code | 1 Byte | 0x46 |
| 02 | Sub function code | 1 Byte | 0x29 |

Response

| | | | |
|----|------------------------|--------|--|
| 00 | Address | 1 Byte | 1 to 247 |
| 01 | Function code | 1 Byte | 0x46 |
| 02 | Sub function code | 1 Byte | 0x29 |
| 03 | Miscellaneous settings | 1 Byte | Bit 7: filter setting, reserved for M-7019R modules firmware version B2.6 and earlier 0: 60Hz rejection 1: 50Hz rejection Bit 6: reserved Bit 5: for M-7017R, M-7017R-A5 and M-7017Z only, reserved for other modules 0: normal mode 1: fast mode Bit 4~0: reserved |

Note: The reserved fields are filled with zeros.

Error Response

| | | | |
|----|----------------|--------|--|
| 00 | Address | 1 Byte | 1 to 247 |
| 01 | Function code | 1 Byte | 0xC6 |
| 02 | Exception code | 1 Byte | 03: incorrect number of bytes received |

3.3.11 Sub-function 42 (0x2A) Write miscellaneous settings

This sub-function code is used to set the miscellaneous settings of a module.

Request

| | | | |
|----|------------------------|--------|--|
| 00 | Address | 1 Byte | 1 to 247 |
| 01 | Function code | 1 Byte | 0x46 |
| 02 | Sub function code | 1 Byte | 0x2A |
| 03 | Miscellaneous settings | 1 Byte | Bit 7: filter setting, reserved for M-7019R modules firmware version B2.6 and earlier 0: 60Hz rejection 1: 50Hz rejection Bit 6: reserved Bit 5: for M-7017R, M-7017R-A5 and M-7017Z only, reserved for other modules 0: normal mode 1: fast mode Bit 4~0: reserved |

Note: The reserved fields are filled with zeros.

Response

| | | | |
|----|------------------------|--------|------------------------|
| 00 | Address | 1 Byte | 1 to 247 |
| 01 | Function code | 1 Byte | 0x46 |
| 02 | Sub function code | 1 Byte | 0x2A |
| 03 | Miscellaneous settings | 1 Byte | 0: OK others: error |

Error Response

| | | | |
|----|----------------|--------|--|
| 00 | Address | 1 Byte | 1 to 247 |
| 01 | Function code | 1 Byte | 0xC6 |
| 02 | Exception code | 1 Byte | 03: reserved bits should be filled with zero, incorrect number of bytes received |

3.3.12 Sub-function 43 (0x2B) Read CJC offset

This sub-function code is used to read the CJC offset setting of a module.

Request

| | | | |
|----|-------------------|--------|--|
| 00 | Address | 1 Byte | 1 to 247 |
| 01 | Function code | 1 Byte | 0x46 |
| 02 | Sub function code | 1 Byte | 0x2B |
| 03 | Channel | 1 Byte | 0x00 for module CJC offset 0x80 ~ 0x87 (0x89 for M-7018Z and M-7019Z) for channel CJC offset, where 0x80 denotes channel 0, 0x81 denotes channel 1, etc. |

Note: This sub-function is only available on M-7018 and M-7019 series modules.

Response

| | | | |
|---------|-------------------|---------|--|
| 00 | Address | 1 Byte | 1 to 247 |
| 01 | Function code | 1 Byte | 0x46 |
| 02 | Sub function code | 1 Byte | 0x2B |
| 03 ~ 04 | CJC offset | 2 Bytes | This is a 2's complement hex CJC offset value. For module CJC offset, it is in 0.01 °C increments. For channel CJC offset, it is in 0.1 °C increments where 00 denotes 0°C, 7F denotes 12.7°C, FF denotes -0.1°C and 80 denotes -12.8°C. |

Error Response

| | | | |
|----|----------------|--------|---|
| 00 | Address | 1 Byte | 1 to 247 |
| 01 | Function code | 1 Byte | 0xC6 |
| 02 | Exception code | 1 Byte | 03: incorrect number of bytes received, reserved byte is not zero |

3.3.13 Sub-function 44 (0x2C) Write CJC offset

This sub-function code is used to set the CJC offset setting of a module.

Request

| | | | |
|---------------|-------------------|---------|--|
| 00 | Address | 1 Byte | 1 to 247 |
| 01 | Function code | 1 Byte | 0x46 |
| 02 | Sub function code | 1 Byte | 0x2C |
| 03 | Channel | 1 Byte | 0x00 for module CJC offset 0x80 ~ 0x87 (0x89 for M-7018Z and M-7019Z) for channel CJC offset, where 0x80 denotes channel 0, 0x81 denotes channel 1, etc. |
| 04 ~ 05 | CJC offset | 2 Bytes | This is a 2's complement hex CJC offset value. For module CJC offset, it is in 0.01°C increments and the absolute value should be less than or equal to 0x1000. For channel CJC offset, it is in 0.1°C increments and in the range 00 ~ FF, where 00 denotes 0°C, 7F denotes 12.7°C, FF denotes -0.1°C and 80 denotes -12.8°C. |

Note: This sub-function is only available on M-7018 and M-7019 series modules.

Response

| | | | |
|----|-------------------|--------|-------------------------|
| 00 | Address | 1 Byte | 1 to 247 |
| 01 | Function code | 1 Byte | 0x46 |
| 02 | Sub function code | 1 Byte | 0x2C |
| 03 | Set CJC offset | 1 Byte | 0: OK, others: error |

Error Response

| | | | |
|----|----------------|--------|---|
| 00 | Address | 1 Byte | 1 to 247 |
| 01 | Function code | 1 Byte | 0xC6 |
| 02 | Exception code | 1 Byte | 03: reserved byte should be zero, CJC offset value out of range, incorrect number of bytes received |

3.3.14 Sub-function 45 (0x2D) Read CJC enabled/disabled status

This sub-function code is used to read the CJC enabled/disabled status of a module.

Request

| | | | |
|----|-------------------|--------|----------|
| 00 | Address | 1 Byte | 1 to 247 |
| 01 | Function code | 1 Byte | 0x46 |
| 02 | Sub function code | 1 Byte | 0x2D |
| 03 | Reserved | 1 Byte | 0x00 |

Note: This sub-function is only available on M-7018 and M-7019 series modules.

Response

| | | | |
|----|-----------------------------|--------|-----------------------------------|
| 00 | Address | 1 Byte | 1 to 247 |
| 01 | Function code | 1 Byte | 0x46 |
| 02 | Sub function code | 1 Byte | 0x2D |
| 03 | CJC enabled/disabled status | 1 Byte | 0: CJC disabled 1: CJC enabled |

Error Response

| | | | |
|----|----------------|--------|--|
| 00 | Address | 1 Byte | 1 to 247 |
| 01 | Function code | 1 Byte | 0xC6 |
| 02 | Exception code | 1 Byte | 03: incorrect number of bytes received |

3.3.15 Sub-function 46 (0x2E) Set CJC enable/disable

This sub-function code is used to enable/disable the CJC of a module.

Request

| | | | |
|----|--------------------|--------|---------------------------------|
| 00 | Address | 1 Byte | 1 to 247 |
| 01 | Function code | 1 Byte | 0x46 |
| 02 | Sub function code | 1 Byte | 0x2E |
| 03 | Reserved | 1 Byte | 0x00 |
| 04 | Enable/disable CJC | 1 Byte | 0: disable CJC 1: enable CJC |

Note: This sub-function is only available on M-7018 and M-7019 series modules.

Response

| | | | |
|----|------------------------|--------|-------------------------|
| 00 | Address | 1 Byte | 1 to 247 |
| 01 | Function code | 1 Byte | 0x46 |
| 02 | Sub function code | 1 Byte | 0x2E |
| 03 | Miscellaneous settings | 1 Byte | 0: OK others: error. |

Error Response

| | | | |
|----|----------------|--------|--|
| 00 | Address | 1 Byte | 1 to 247 |
| 01 | Function code | 1 Byte | 0xC6 |
| 02 | Exception code | 1 Byte | 03: reserved byte is not zero, setting byte incorrect, incorrect number of bytes received |

3.3.16 Sub-function 47 (0x2F) Read CJC update setting

This sub-function code is used to read the CJC update settings of a module.

Request

| | | | |
|----|-------------------|--------|----------|
| 00 | Address | 1 Byte | 1 to 247 |
| 01 | Function code | 1 Byte | 0x46 |
| 02 | Sub function code | 1 Byte | 0x2F |

Note: This sub-function is only available on M-7019 series modules.

Response

| | | | |
|----|--------------------------------|--------|---|
| 00 | Address | 1 Byte | 1 to 247 |
| 01 | Function code | 1 Byte | 0x46 |
| 02 | Sub function code | 1 Byte | 0x2F |
| 03 | CJC temperature update setting | 1 Byte | 0: CJC temperature update has been stopped 1: CJC temperature update has been started 2: Update CJC temperature once only |

Error Response

| | | | |
|----|----------------|--------|--|
| 00 | Address | 1 Byte | 1 to 247 |
| 01 | Function code | 1 Byte | 0xC6 |
| 02 | Exception code | 1 Byte | 03: incorrect number of bytes received |

3.3.17 Sub-function 48 (0x30) Write CJC update setting

This sub-function code is used to set the CJC update setting of a module.

Request

| | | | |
|----|--------------------------------|--------|---|
| 00 | Address | 1 Byte | 1 to 247 |
| 01 | Function code | 1 Byte | 0x46 |
| 02 | Sub function code | 1 Byte | 0x30 |
| 03 | CJC temperature update setting | 1 Byte | 0: stop CJC temperature update 1: start CJC temperature update 2: Update CJC temperature once only, after the command is received |

Note: This sub-function is only available on M-7019 series modules.

Response

| | | | |
|----|------------------------|--------|-----------------------|
| 00 | Address | 1 Byte | 1 to 247 |
| 01 | Function code | 1 Byte | 0x46 |
| 02 | Sub function code | 1 Byte | 0x30 |
| 03 | Miscellaneous settings | 1 Byte | 0: OK, others: error. |

Error Response

| | | | |
|----|----------------|--------|--|
| 00 | Address | 1 Byte | 1 to 247 |
| 01 | Function code | 1 Byte | 0xC6 |
| 02 | Exception code | 1 Byte | 03: setting byte incorrect, incorrect number of bytes received |

3.4 Address Mappings

3.4.1 M-7017 Series Address Mappings (Base 1)

For M-7017 series firmware version B300 and later, the Modbus address mappings are as follows.

| Address | Description | Attribute | | | | | | | | | | | | | | | | | | | | |
|--------------------------------------|---|-----------|-------|--------|------|------|------|------|------|------|------|------|------|------|------|------|------|-------|-------|-------|--------|-----|
| 10129 ~ 10136 00129 ~ 00136 | Over/under range status of channel 0 to 7 for 4 ~ 20mA or 0 ~ 20mA ranges | R | | | | | | | | | | | | | | | | | | | | |
| 30001 ~ 30008 40001 ~ 40008 | Analog input value of channel 0 to 7 | R | | | | | | | | | | | | | | | | | | | | |
| 40257* ~ 40264 | Type code of channel 0 to 7, only available to the M-7017R firmware version B3.9 and later | R/W | | | | | | | | | | | | | | | | | | | | |
| 40481 | Firmware version (low word) | R | | | | | | | | | | | | | | | | | | | | |
| 40482 | Firmware version (high word) | R | | | | | | | | | | | | | | | | | | | | |
| 40483 | Module name (low word) | R | | | | | | | | | | | | | | | | | | | | |
| 40484 | Module name (high word) | R | | | | | | | | | | | | | | | | | | | | |
| 40485 | Module address, valid range: 1 ~ 247 | R/W | | | | | | | | | | | | | | | | | | | | |
| 40486 | Bits 5:0 Baud rate, 0x03 ~ 0x0A <table border="1" data-bbox="399 1541 1066 1720"> <tbody> <tr> <td>Code</td> <td>0x03</td> <td>0x04</td> <td>0x05</td> <td>0x06</td> </tr> <tr> <td>Baud</td> <td>1200</td> <td>2400</td> <td>4800</td> <td>9600</td> </tr> <tr> <td>Code</td> <td>0x07</td> <td>0x08</td> <td>0x09</td> <td>0x0A</td> </tr> <tr> <td>Baud</td> <td>19200</td> <td>38400</td> <td>57600</td> <td>115200</td> </tr> </tbody> </table> Bits 7:6 00: no parity, 1 stop bit 01: no parity, 2 stop bits 10: even parity, 1 stop bit 11: odd parity, 1 stop bit | Code | 0x03 | 0x04 | 0x05 | 0x06 | Baud | 1200 | 2400 | 4800 | 9600 | Code | 0x07 | 0x08 | 0x09 | 0x0A | Baud | 19200 | 38400 | 57600 | 115200 | R/W |
| Code | 0x03 | 0x04 | 0x05 | 0x06 | | | | | | | | | | | | | | | | | | |
| Baud | 1200 | 2400 | 4800 | 9600 | | | | | | | | | | | | | | | | | | |
| Code | 0x07 | 0x08 | 0x09 | 0x0A | | | | | | | | | | | | | | | | | | |
| Baud | 19200 | 38400 | 57600 | 115200 | | | | | | | | | | | | | | | | | | |

| Address | Description | Attribute |
|---------|--|-----------|
| 40487 | Type code | R/W |
| 40488 | Modbus response delay time in ms, valid range: 0 ~ 30 | R/W |
| 40489 | Host watchdog timeout value, 0 ~ 255, in 0.1s | R/W |
| 40490 | Channel enable/disable, 00h ~ FFh | R/W |
| 40492 | Host watchdog timeout count, write 0 to clear | R/W |
| 00257 | Protocol, 0: DCON, 1: Modbus RTU | R/W |
| 00259 | Filter setting, 0: 60Hz rejection, 1: 50Hz rejection | R/W |
| 00261 | 1: enable, 0: disable host watchdog | R/W |
| 00269 | Modbus data format, 0: hex, 1: engineering | R/W |
| 00270 | Host watch dog timeout status, write 1 to clear host watch dog timeout status | R/W |
| 00271* | 1: enable, 0: disable fast mode | R/W |
| 00273 | Reset status, 1: first read after powered on, 0: not the first read after powered on | R |

Notes:

1. Addresses 40257 ~ 40264 are only available to the M-7017R firmware version B3.9 and later.
2. Address 00271 is only available to the M-7017R and M-7017R-A5.

3.4.2 M-7017RMS Address Mappings (Base 1)

| Address | Description | Attribute | | | | | | | | | | | | | | | | | | | | |
|--------------------------------------|---|-----------|-------|--------|------|------|------|------|------|------|------|------|------|------|------|------|------|-------|-------|-------|--------|-----|
| 30001 ~ 30008 40001 ~ 40008 | Analog input value of channel 0 to 7 | R | | | | | | | | | | | | | | | | | | | | |
| 40257 ~ 40264 | Type code of channel 0 to 7 | R/W | | | | | | | | | | | | | | | | | | | | |
| 40481 | Firmware version (low word) | R | | | | | | | | | | | | | | | | | | | | |
| 40482 | Firmware version (high word) | R | | | | | | | | | | | | | | | | | | | | |
| 40483 | Module name (low word) | R | | | | | | | | | | | | | | | | | | | | |
| 40484 | Module name (high word) | R | | | | | | | | | | | | | | | | | | | | |
| 40485 | Module address, valid range: 1 ~ 247 | R/W | | | | | | | | | | | | | | | | | | | | |
| 40486 | Bits 5:0 Baud rate, 0x03 ~ 0x0A <table border="1" data-bbox="399 1086 1066 1265"> <tbody> <tr> <td>Code</td> <td>0x03</td> <td>0x04</td> <td>0x05</td> <td>0x06</td> </tr> <tr> <td>Baud</td> <td>1200</td> <td>2400</td> <td>4800</td> <td>9600</td> </tr> <tr> <td>Code</td> <td>0x07</td> <td>0x08</td> <td>0x09</td> <td>0x0A</td> </tr> <tr> <td>Baud</td> <td>19200</td> <td>38400</td> <td>57600</td> <td>115200</td> </tr> </tbody> </table> Bits 7:6 00: no parity, 1 stop bit 01: no parity, 2 stop bits 10: even parity, 1 stop bit 11: odd parity, 1 stop bit | Code | 0x03 | 0x04 | 0x05 | 0x06 | Baud | 1200 | 2400 | 4800 | 9600 | Code | 0x07 | 0x08 | 0x09 | 0x0A | Baud | 19200 | 38400 | 57600 | 115200 | R/W |
| Code | 0x03 | 0x04 | 0x05 | 0x06 | | | | | | | | | | | | | | | | | | |
| Baud | 1200 | 2400 | 4800 | 9600 | | | | | | | | | | | | | | | | | | |
| Code | 0x07 | 0x08 | 0x09 | 0x0A | | | | | | | | | | | | | | | | | | |
| Baud | 19200 | 38400 | 57600 | 115200 | | | | | | | | | | | | | | | | | | |
| 40487 | Type code | R/W | | | | | | | | | | | | | | | | | | | | |
| 40488 | Modbus response delay time in ms, valid range: 0 ~ 30 | R/W | | | | | | | | | | | | | | | | | | | | |
| 40489 | Host watchdog timeout value, 0 ~ 255, in 0.1s | R/W | | | | | | | | | | | | | | | | | | | | |
| 40490 | Channel enable/disable, 00h ~ FFh | R/W | | | | | | | | | | | | | | | | | | | | |
| 40492 | Host watchdog timeout count, write 0 to clear | R/W | | | | | | | | | | | | | | | | | | | | |

| Address | Description | Attribute |
|----------------|--|------------------|
| 00257 | Protocol, 0: DCON, 1: Modbus RTU | R/W |
| 00259 | Filter setting, 0: 60Hz rejection, 1: 50Hz rejection | R/W |
| 00261 | 1: enable, 0: disable host watchdog | R/W |
| 00269 | Modbus data format, 0: hex, 1: engineering | R/W |
| 00270 | Host watch dog timeout status, write 1 to clear host watch dog timeout status | R/W |
| 00273 | Reset status, 1: first read after powered on, 0: not the first read after powered on | R |

3.4.3 M-7017mC-16 Address Mappings (Base 1)

| Address | Description | Attribute |
|--------------------------------------|--|-----------|
| 30001 ~ 30016 40001 ~ 40016 | Analog input value of channel 0 to 15 | R |
| 40017 ~ 40018 | RTC time in Epoch time format | R/W |
| 40257 ~ 40272 | Type code of channel 0 to 15 | R/W |
| 40481 | Firmware version (low word) | R |
| 40482 | Firmware version (high word) | R |
| 40483 | Module name (low word) | R |
| 40484 | Module name (high word) | R |
| 40485 | RS-485 module address, 1 to 247 | R/W |
| 40486 | RS-485 baud rate and parity settings Bits 5:0 Baud rate, valid range: 3 ~ 10 Bits 7:6 00: no parity, 1 stop bit 01: no parity, 2 stop bit 10: even parity, 1 stop bit 11: odd parity , 1 stop bit | R/W |
| 40488 | RS-485 response delay time in ms, valid range, 0 ~ 30 | R/W |
| 40489 | RS-485 host watchdog timeout value, 0 ~ 255, in 0.1s | R/W |
| 40490 | Channel enable/disable, 0000h ~ FFFFh | R/W |
| 40492 | RS-485 host watchdog timeout count, write 0 to clear | R/W |

| Address | Description | Attribute |
|------------------|--|------------------|
| 40865 | RTC year, 2000 to 2159 | R/W |
| 40866 | RTC month, 1 to 12 | R/W |
| 40867 | RTC date, 1 to 31 | R/W |
| 40868 | RTC hour, 0 to 23 | R/W |
| 40869 | RTC minute, 0 to 59 | R/W |
| 40870 | RTC second, 0 to 59 | R/W |
| 40871 ~ 40872 | The index of the last log record | R |
| 40873 ~ 40874 | The index of the log record to be read | R/W |
| 40875 | The status of the data logging, 0: stopped, 1: running | R |
| 40876 | The data logger command, 0: stop, 1: run in continuous mode, 2: run in period mode | R/W |
| 40877 | Continue writing when data logger is full, 0: no, 1: yes | R/W |
| 40878 | Hour of the data logger sampling period, 0 ~ 24 | R/W |
| 40879 | Minute of the data logger sampling period, 0 ~ 59 | R/W |
| 40880 | Second of the data logger sampling period, 0 ~ 59 | R/W |
| 40881 | Starting year when logging in period mode, 2000 ~ 2159 | R/W |
| 40882 | Starting month when logging in period mode, 1 ~ 12 | R/W |
| 40883 | Starting date when logging in period mode, 1 ~ 31 | R/W |
| 40884 | Starting hour when logging in period mode, 0 ~ 23 | R/W |

| Address | Description | Attribute |
|--------------------------------------|---|------------------|
| 40885 | Starting minute when logging in period mode, 0 ~ 59 | R/W |
| 40886 | Starting second when logging in period mode, 0 ~ 59 | R/W |
| 40887 | Ending year when logging in period mode, 2000 ~ 2159 | R/W |
| 40888 | Ending month when logging in period mode, 1 ~ 12 | R/W |
| 40889 | Ending date when logging in period mode, 1 ~ 31 | R/W |
| 40890 | Ending hour when logging in period mode, 0 ~ 23 | R/W |
| 40891 | Ending minute when logging in period mode, 0 ~ 59 | R/W |
| 40892 | Ending second when logging in period mode, 0 ~ 59 | R/W |
| 31001 ~ 31108 41001 ~ 41108 | Read log data and it should be multiple of 18 registers. For each 18 registers, the first 16 registers are for the analog input data and the last 2 registers are for the time stamp. | R |

| Address | Description | Attribute |
|--------------------------------------|---|------------------|
| 10129 ~ 10144 00129 ~ 00144 | Over/under range status of channel 0 to 15 for 4 ~ 20mA or 0 ~ 20mA ranges | R |
| 00257 | RS-485 Protocol, 0: DCON, 1: Modbus RTU | R/W |
| 00261 | RS-485 host watchdog mode, 1: enable, 0: disable. | R/W |
| 00269 | Modbus data format, 0: hex, 1: engineering | R/W |
| 00270 | Host watch dog timeout status, write 1 to clear host watch dog timeout status Only for Modbus RTU protocol | R/W |
| 00271 | 0: normal mode, 1: fast mode | R/W |
| 00272 | Write 1 to load factory calibration parameters | W |
| 00273 | Reset status, 1: first read after powered on, 0: not the first read after powered on | R |
| 00283 | 0: little-endian, 1: big-endian | R/W |

3.4.4 M-7017Z Address Mappings (Base 1)

| Address | Description | Attribute | | | | | | | | | | | | | | | | | | | | |
|--------------------------------------|---|-----------|-------|--------|------|------|------|------|------|------|------|------|------|------|------|------|------|-------|-------|-------|--------|-----|
| 10129 ~ 10138 00129 ~ 00138 | Over/under range status of channel 0 to 9 for 4 ~ 20mA or 0 ~ 20mA ranges | R | | | | | | | | | | | | | | | | | | | | |
| 30001 ~ 30020 40001 ~ 40020 | Analog input value of channel 0 to 19 | R | | | | | | | | | | | | | | | | | | | | |
| 40257 ~ 40276 | Type code of channel 0 to 19 | R/W | | | | | | | | | | | | | | | | | | | | |
| 40481 | Firmware version (low word) | R | | | | | | | | | | | | | | | | | | | | |
| 40482 | Firmware version (high word) | R | | | | | | | | | | | | | | | | | | | | |
| 40483 | Module name (low word) | R | | | | | | | | | | | | | | | | | | | | |
| 40484 | Module name (high word) | R | | | | | | | | | | | | | | | | | | | | |
| 40485 | Module address, valid range: 1 ~ 247 | R/W | | | | | | | | | | | | | | | | | | | | |
| 40486 | Bits 5:0 Baud rate, 0x03 ~ 0x0A <table border="1" style="margin-left: 20px;"> <tbody> <tr> <td>Code</td> <td>0x03</td> <td>0x04</td> <td>0x05</td> <td>0x06</td> </tr> <tr> <td>Baud</td> <td>1200</td> <td>2400</td> <td>4800</td> <td>9600</td> </tr> <tr> <td>Code</td> <td>0x07</td> <td>0x08</td> <td>0x09</td> <td>0x0A</td> </tr> <tr> <td>Baud</td> <td>19200</td> <td>38400</td> <td>57600</td> <td>115200</td> </tr> </tbody> </table> Bits 7:6 00: no parity, 1 stop bit 01: no parity, 2 stop bits 10: even parity, 1 stop bit 11: odd parity, 1 stop bit | Code | 0x03 | 0x04 | 0x05 | 0x06 | Baud | 1200 | 2400 | 4800 | 9600 | Code | 0x07 | 0x08 | 0x09 | 0x0A | Baud | 19200 | 38400 | 57600 | 115200 | R/W |
| Code | 0x03 | 0x04 | 0x05 | 0x06 | | | | | | | | | | | | | | | | | | |
| Baud | 1200 | 2400 | 4800 | 9600 | | | | | | | | | | | | | | | | | | |
| Code | 0x07 | 0x08 | 0x09 | 0x0A | | | | | | | | | | | | | | | | | | |
| Baud | 19200 | 38400 | 57600 | 115200 | | | | | | | | | | | | | | | | | | |
| 40488 | Modbus response delay time in ms, valid range: 0 ~ 30 | R/W | | | | | | | | | | | | | | | | | | | | |
| 40489 | Host watchdog timeout value, 0 ~ 255, in 0.1s | R/W | | | | | | | | | | | | | | | | | | | | |

| Address | Description | Attribute |
|----------------|--|------------------|
| 40490 | Channel enable/disable, low word | R/W |
| 40492 | Host watchdog timeout count, write 0 to clear | R/W |
| 40497 | Channel enable/disable, high word | R/W |
| 00257 | Protocol, 0: DCON, 1: Modbus RTU | R/W |
| 00259 | Filter setting, 0: 60Hz rejection, 1: 50Hz rejection | R/W |
| 00260 | Modbus host watchdog mode 0: same as I-7000 1: can use AO and DO command to clear host watchdog timeout status | R/W |
| 00261 | 1: enable, 0: disable host watchdog | R/W |
| 00269 | Modbus data format, 0: hex, 1: engineering | R/W |
| 00270 | Host watch dog timeout status, write 1 to clear host watch dog timeout status | R/W |
| 00271 | 1: enable, 0: disable fast mode | R/W |
| 00273 | Reset status, 1: first read after powered on, 0: not the first read after powered on | R |
| 00277 | 1: single-ended mode, 0: differential mode | R/W |

3.4.5 M-7018 Series Address Mappings (Base 1)

For M-7018 series firmware version B305 and later, the Modbus address mappings are as follows.

| Address | Description | Attribute | | | | | | | | | | | | | | | | | | | | |
|--------------------------------------|---|-----------|-------|--------|------|------|------|------|------|------|------|------|------|------|------|------|------|-------|-------|-------|--------|-----|
| 30001 ~ 30008 40001 ~ 40008 | Analog input value of channel 0 to 7 | R | | | | | | | | | | | | | | | | | | | | |
| 30129 40129 | CJC temperature in 0.01 °C | R | | | | | | | | | | | | | | | | | | | | |
| 40257 ~ 40264 | Type code of channel 0 to 7, only available to the M-7018R firmware version B405 and later | R/W | | | | | | | | | | | | | | | | | | | | |
| 40353 ~ 40360 | CJC offset of channel 0 to 7 in 0.1 °C. 1 for 0.1, 127 for 12.7, 255 for -0.1, 128 for -12.8 | R/W | | | | | | | | | | | | | | | | | | | | |
| 40481 | Firmware version (low word) | R | | | | | | | | | | | | | | | | | | | | |
| 40482 | Firmware version (high word) | R | | | | | | | | | | | | | | | | | | | | |
| 40483 | Module name (low word) | R | | | | | | | | | | | | | | | | | | | | |
| 40484 | Module name (high word) | R | | | | | | | | | | | | | | | | | | | | |
| 40485 | Module address, valid range: 1 ~ 247 | R/W | | | | | | | | | | | | | | | | | | | | |
| 40486 | Bits 5:0 Baud rate, 0x03 ~ 0x0A <table border="1" data-bbox="399 1473 1066 1653"> <tbody> <tr> <td>Code</td> <td>0x03</td> <td>0x04</td> <td>0x05</td> <td>0x06</td> </tr> <tr> <td>Baud</td> <td>1200</td> <td>2400</td> <td>4800</td> <td>9600</td> </tr> <tr> <td>Code</td> <td>0x07</td> <td>0x08</td> <td>0x09</td> <td>0x0A</td> </tr> <tr> <td>Baud</td> <td>19200</td> <td>38400</td> <td>57600</td> <td>115200</td> </tr> </tbody> </table> Bits 7:6 00: no parity, 1 stop bit 01: no parity, 2 stop bits 10: even parity, 1 stop bit 11: odd parity, 1 stop bit | Code | 0x03 | 0x04 | 0x05 | 0x06 | Baud | 1200 | 2400 | 4800 | 9600 | Code | 0x07 | 0x08 | 0x09 | 0x0A | Baud | 19200 | 38400 | 57600 | 115200 | R/W |
| Code | 0x03 | 0x04 | 0x05 | 0x06 | | | | | | | | | | | | | | | | | | |
| Baud | 1200 | 2400 | 4800 | 9600 | | | | | | | | | | | | | | | | | | |
| Code | 0x07 | 0x08 | 0x09 | 0x0A | | | | | | | | | | | | | | | | | | |
| Baud | 19200 | 38400 | 57600 | 115200 | | | | | | | | | | | | | | | | | | |
| 40487 | Type code | R/W | | | | | | | | | | | | | | | | | | | | |

| Address | Description | Attribute |
|----------------|--|------------------|
| 40488 | Modbus response delay time in ms, valid range: 0 ~ 30 | R/W |
| 40489 | Host watchdog timeout value, 0 ~ 255, in 0.1s | R/W |
| 40490 | Channel enable/disable, 00h ~ FFh | R/W |
| 40491 | Module CJC offset in 0.01 °C | R/W |
| 40492 | Host watchdog timeout count, write 0 to clear | R/W |
| 00257 | Protocol, 0: DCON, 1: Modbus RTU | R/W |
| 00259 | Filter setting, 0: 60Hz rejection, 1: 50Hz rejection | R/W |
| 00260 | Modbus host watchdog mode 0: same as I-7000 1: can use AO and DO command to clear host watchdog timeout status | R/W |
| 00261 | 1: enable, 0: disable host watchdog | R/W |
| 00268 | 1: enable, 0: disable CJC | R/W |
| 00269 | Modbus data format, 0: hex, 1: engineering | R/W |
| 00270 | Host watch dog timeout status, write 1 to clear host watch dog timeout status | R/W |
| 00273 | Reset status, 1: first read after powered on, 0: not the first read after powered on | R |
| 00276 | Open thermocouple detection, 1: enable, 0: disable (for firmware version B405 and later) | R/W |

Note:

Addresses 40257 ~ 40264 and 00276 are only available to the M-7018R firmware version B4.5 and later.

3.4.6 M-7018Z Address Mappings (Base 1)

For M-7018Z the Modbus address mappings are as follows.

| Address | Description | Attribute | | | | | | | | | | | | | | | | | | | | |
|--------------------------------------|---|-----------|-------|--------|------|------|------|------|------|------|------|------|------|------|------|------|------|-------|-------|-------|--------|-----|
| 30001 ~ 30010 40001 ~ 40010 | Analog input value of channel 0 to 9 | R | | | | | | | | | | | | | | | | | | | | |
| 30129 40129 | CJC temperature in 0.01 °C | R | | | | | | | | | | | | | | | | | | | | |
| 40257 ~ 40266 | Type code of channel 0 to 9 | R/W | | | | | | | | | | | | | | | | | | | | |
| 40353 ~ 40362 | CJC offset of channel 0 to 9 in 0.1 °C. 1 for 0.1, 127 for 12.7, 255 for –0.1, 128 for –12.8 | R/W | | | | | | | | | | | | | | | | | | | | |
| 40481 | Firmware version (low word) | R | | | | | | | | | | | | | | | | | | | | |
| 40482 | Firmware version (high word) | R | | | | | | | | | | | | | | | | | | | | |
| 40483 | Module name (low word) | R | | | | | | | | | | | | | | | | | | | | |
| 40484 | Module name (high word) | R | | | | | | | | | | | | | | | | | | | | |
| 40485 | Module address, valid range: 1 ~ 247 | R/W | | | | | | | | | | | | | | | | | | | | |
| 40486 | Bits 5:0 Baud rate, 0x03 ~ 0x0A <table border="1" style="margin-left: 20px;"> <tbody> <tr> <td>Code</td> <td>0x03</td> <td>0x04</td> <td>0x05</td> <td>0x06</td> </tr> <tr> <td>Baud</td> <td>1200</td> <td>2400</td> <td>4800</td> <td>9600</td> </tr> <tr> <td>Code</td> <td>0x07</td> <td>0x08</td> <td>0x09</td> <td>0x0A</td> </tr> <tr> <td>Baud</td> <td>19200</td> <td>38400</td> <td>57600</td> <td>115200</td> </tr> </tbody> </table> Bits 7:6 00: no parity, 1 stop bit 01: no parity, 2 stop bits 10: even parity, 1 stop bit 11: odd parity, 1 stop bit | Code | 0x03 | 0x04 | 0x05 | 0x06 | Baud | 1200 | 2400 | 4800 | 9600 | Code | 0x07 | 0x08 | 0x09 | 0x0A | Baud | 19200 | 38400 | 57600 | 115200 | R/W |
| Code | 0x03 | 0x04 | 0x05 | 0x06 | | | | | | | | | | | | | | | | | | |
| Baud | 1200 | 2400 | 4800 | 9600 | | | | | | | | | | | | | | | | | | |
| Code | 0x07 | 0x08 | 0x09 | 0x0A | | | | | | | | | | | | | | | | | | |
| Baud | 19200 | 38400 | 57600 | 115200 | | | | | | | | | | | | | | | | | | |
| 40488 | Modbus response delay time in ms, valid range: 0 ~ 30 | R/W | | | | | | | | | | | | | | | | | | | | |

| Address | Description | Attribute |
|----------------|--|------------------|
| 40489 | Host watchdog timeout value, 0 ~ 255, in 0.1s | R/W |
| 40490 | Channel enable/disable, 000h ~ 3FFh | R/W |
| 40491 | Module CJC offset in 0.01 °C | R/W |
| 40492 | Host watchdog timeout count, write 0 to clear | R/W |
| 00257 | Protocol, 0: DCON, 1: Modbus RTU | R/W |
| 00259 | Filter setting, 0: 60Hz rejection, 1: 50Hz rejection | R/W |
| 00260 | Modbus host watchdog mode 0: same as I-7000 1: can use AO and DO command to clear host watchdog timeout status | R/W |
| 00261 | 1: enable, 0: disable host watchdog | R/W |
| 00268 | 1: enable, 0: disable CJC | R/W |
| 00269 | Modbus data format, 0: hex, 1: engineering | R/W |
| 00270 | Host watch dog timeout status, write 1 to clear host watch dog timeout status | R/W |
| 00273 | Reset status, 1: first read after powered on, 0: not the first read after powered on | R |
| 00276 | Open thermocouple detection, 1: enable, 0: disable (for firmware version B404 and later) | R/W |

3.4.7 M-7018-16 Address Mappings (Base 1)

For M-7018-16, the Modbus address mappings are as follows.

| Address | Description | Attribute | | | | | | | | | | | | | | | | | | | | |
|--------------------------------------|---|-----------|-------|--------|------|------|------|------|------|------|------|------|------|------|------|------|------|-------|-------|-------|--------|-----|
| 30001 ~ 30016 40001 ~ 40016 | Analog input value of channel 0 to 15 | R | | | | | | | | | | | | | | | | | | | | |
| 30033 ~ 30048 40033 ~ 40048 | Temperature reading of channel 0 to 15 in 1°C | R | | | | | | | | | | | | | | | | | | | | |
| 30129 40129 | CJC temperature in 0.01°C | R | | | | | | | | | | | | | | | | | | | | |
| 40353 ~ 40368 | CJC offset of channel 0 to 15 in 0.1°C. 1 for 0.1, 127 for 12.7, 255 for -0.1, 128 for -12.8 | R/W | | | | | | | | | | | | | | | | | | | | |
| 40481 | Firmware version (low word) | R | | | | | | | | | | | | | | | | | | | | |
| 40482 | Firmware version (high word) | R | | | | | | | | | | | | | | | | | | | | |
| 40483 | Module name (low word) | R | | | | | | | | | | | | | | | | | | | | |
| 40484 | Module name (high word) | R | | | | | | | | | | | | | | | | | | | | |
| 40485 | Module address, valid range: 1 ~ 247 | R/W | | | | | | | | | | | | | | | | | | | | |
| 40486 | Bits 5:0 Baud rate, 0x03 ~ 0x0A <table border="1" data-bbox="399 1523 1066 1702"> <tbody> <tr> <td>Code</td> <td>0x03</td> <td>0x04</td> <td>0x05</td> <td>0x06</td> </tr> <tr> <td>Baud</td> <td>1200</td> <td>2400</td> <td>4800</td> <td>9600</td> </tr> <tr> <td>Code</td> <td>0x07</td> <td>0x08</td> <td>0x09</td> <td>0x0A</td> </tr> <tr> <td>Baud</td> <td>19200</td> <td>38400</td> <td>57600</td> <td>115200</td> </tr> </tbody> </table> Bits 7:6 00: no parity, 1 stop bit 01: no parity, 2 stop bits 10: even parity, 1 stop bit 11: odd parity, 1 stop bit | Code | 0x03 | 0x04 | 0x05 | 0x06 | Baud | 1200 | 2400 | 4800 | 9600 | Code | 0x07 | 0x08 | 0x09 | 0x0A | Baud | 19200 | 38400 | 57600 | 115200 | R/W |
| Code | 0x03 | 0x04 | 0x05 | 0x06 | | | | | | | | | | | | | | | | | | |
| Baud | 1200 | 2400 | 4800 | 9600 | | | | | | | | | | | | | | | | | | |
| Code | 0x07 | 0x08 | 0x09 | 0x0A | | | | | | | | | | | | | | | | | | |
| Baud | 19200 | 38400 | 57600 | 115200 | | | | | | | | | | | | | | | | | | |

| Address | Description | Attribute |
|----------------|--|------------------|
| 40487 | Type code | R/W |
| 40488 | Modbus response delay time in ms, valid range: 0 ~ 30 | R/W |
| 40489 | Host watchdog timeout value, 0 ~ 255, in 0.1s | R/W |
| 40490 | Channel enable/disable, 00h ~ FFh | R/W |
| 40491 | Module CJC offset in 0.01 °C | R/W |
| 40492 | Host watchdog timeout count, write 0 to clear | R/W |
| 00257 | Protocol, 0: DCON, 1: Modbus RTU | R/W |
| 00259 | Filter setting, 0: 60Hz rejection, 1: 50Hz rejection | R/W |
| 00260 | Modbus host watchdog mode 0: same as I-7000 1: can use AO and DO command to clear host watchdog timeout status | R/W |
| 00261 | 1: enable, 0: disable host watchdog | R/W |
| 00268 | 1: enable, 0: disable CJC | R/W |
| 00269 | Modbus data format, 0: hex, 1: engineering | R/W |
| 00270 | Host watch dog timeout status, write 1 to clear host watch dog timeout status | R/W |
| 00273 | Reset status, 1: first read after powered on, 0: not the first read after powered on | R |

3.4.8 M-7019R Address Mappings (Base 1)

For M-7019R firmware version B300 and later, the Modbus address mappings are as follows.

| Address | Description | Attribute | | | | | | | | | | | | | | | | | | | | |
|--------------------------------------|---|-----------|-------|--------|------|------|------|------|------|------|------|------|------|------|------|------|------|-------|-------|-------|--------|-----|
| 10129 ~ 10136 00129 ~ 00136 | Over/under range status of channel 0 to 7 | R | | | | | | | | | | | | | | | | | | | | |
| 30001 ~ 30008 40001 ~ 40008 | Analog input value of channel 0 to 7 | R | | | | | | | | | | | | | | | | | | | | |
| 30129 40129 | CJC temperature in 0.01 °C | R | | | | | | | | | | | | | | | | | | | | |
| 40257 ~ 40264 | Type code of channel 0 to 7 | R/W | | | | | | | | | | | | | | | | | | | | |
| 40289 ~ 40296 | Temperature offset of channel 0 to 7 in 0.1 °C, valid range: -128 ~ 127 | R/W | | | | | | | | | | | | | | | | | | | | |
| 40353 ~ 40360 | CJC offset of channel 0 to 7 in 0.01 °C, valid range: -4096 ~ 4096 | R/W | | | | | | | | | | | | | | | | | | | | |
| 40481 | Firmware version (low word) | R | | | | | | | | | | | | | | | | | | | | |
| 40482 | Firmware version (high word) | R | | | | | | | | | | | | | | | | | | | | |
| 40483 | Module name (low word) | R | | | | | | | | | | | | | | | | | | | | |
| 40484 | Module name (high word) | R | | | | | | | | | | | | | | | | | | | | |
| 40485 | Module address, valid range: 1 ~ 247 | R/W | | | | | | | | | | | | | | | | | | | | |
| 40486 | Bits 5:0 Baud rate, 0x03 ~ 0x0A <table border="1" style="margin-left: 20px;"> <tbody> <tr> <td>Code</td> <td>0x03</td> <td>0x04</td> <td>0x05</td> <td>0x06</td> </tr> <tr> <td>Baud</td> <td>1200</td> <td>2400</td> <td>4800</td> <td>9600</td> </tr> <tr> <td>Code</td> <td>0x07</td> <td>0x08</td> <td>0x09</td> <td>0x0A</td> </tr> <tr> <td>Baud</td> <td>19200</td> <td>38400</td> <td>57600</td> <td>115200</td> </tr> </tbody> </table> Bits 7:6 00: no parity, 1 stop bit 01: no parity, 2 stop bits 10: even parity, 1 stop bit 11: odd parity, 1 stop bit | Code | 0x03 | 0x04 | 0x05 | 0x06 | Baud | 1200 | 2400 | 4800 | 9600 | Code | 0x07 | 0x08 | 0x09 | 0x0A | Baud | 19200 | 38400 | 57600 | 115200 | R/W |
| Code | 0x03 | 0x04 | 0x05 | 0x06 | | | | | | | | | | | | | | | | | | |
| Baud | 1200 | 2400 | 4800 | 9600 | | | | | | | | | | | | | | | | | | |
| Code | 0x07 | 0x08 | 0x09 | 0x0A | | | | | | | | | | | | | | | | | | |
| Baud | 19200 | 38400 | 57600 | 115200 | | | | | | | | | | | | | | | | | | |

| Address | Description | Attribute |
|----------------|--|------------------|
| 40488 | Modbus response delay time in ms, valid range: 0 ~ 30 | R/W |
| 40489 | Host watchdog timeout value, 0 ~ 255, in 0.1s | R/W |
| 40490 | Channel enable/disable, 00h ~ FFh | R/W |
| 40491 | Module CJC offset in 0.01 °C | R/W |
| 40492 | Host watchdog timeout count, write 0 to clear | R/W |
| 40493 | CJC update setting, 0 ~ 2 | R/W |
| 00257 | Protocol, 0: DCON, 1: Modbus RTU | R/W |
| 00259 | Filter setting, 0: 60Hz rejection, 1: 50Hz rejection | R/W |
| 00260 | Modbus host watchdog mode 0: same as I-7000 1: can use AO and DO command to clear host watchdog timeout status | R/W |
| 00261 | 1: enable, 0: disable host watchdog | R/W |
| 00268 | 1: enable, 0: disable CJC | R/W |
| 00269 | Modbus data format, 0: hex, 1: engineering | R/W |
| 00270 | Host watch dog timeout status, write 1 to clear host watch dog timeout status | R/W |
| 00272 | Write 1 to load factory calibration parameters | W |
| 00273 | Reset status, 1: first read after powered on, 0: not the first read after powered on | R |
| 00274 | Sampling rate, 1: 8Hz, 0: 10Hz | R/W |
| 00276 | Open thermocouple detection, 1: enable, 0: disable (for firmware version B307 and later) | R/W |

Notes:

1. The max number of analog output registers written in a command is 11.

2. The command of loading factory calibration parameters takes about 3 seconds. The next command should be sent after 3 seconds.

3.4.9 M-7019Z Address Mappings (Base 1)

| Address | Description | Attribute | | | | | | | | | | | | | | | | | | | | |
|--------------------------------------|--|-----------|-------|--------|------|------|------|------|------|------|------|------|------|------|------|------|------|-------|-------|-------|--------|-----|
| 10129 ~ 10138 00129 ~ 00138 | Over/under range status of channel 0 to 9 | R | | | | | | | | | | | | | | | | | | | | |
| 30001 ~ 30010 40001 ~ 40010 | Analog input value of channel 0 to 9 | R | | | | | | | | | | | | | | | | | | | | |
| 30129 40129 | CJC temperature in 0.01 °C | R | | | | | | | | | | | | | | | | | | | | |
| 40257 ~ 40266 | Type code of channel 0 to 9 | R/W | | | | | | | | | | | | | | | | | | | | |
| 40289 ~ 40298 | Temperature offset of channel 0 to 9 in 0.1 °C, valid range: -128 ~ 127 | R/W | | | | | | | | | | | | | | | | | | | | |
| 40353 ~ 40362 | CJC offset of channel 0 to 9 in 0.01 °C, valid range: -4096 ~ 4096 | R/W | | | | | | | | | | | | | | | | | | | | |
| 40481 | Firmware version (low word) | R | | | | | | | | | | | | | | | | | | | | |
| 40482 | Firmware version (high word) | R | | | | | | | | | | | | | | | | | | | | |
| 40483 | Module name (low word) | R | | | | | | | | | | | | | | | | | | | | |
| 40484 | Module name (high word) | R | | | | | | | | | | | | | | | | | | | | |
| 40485 | Module address, valid range: 1 ~ 247 | R/W | | | | | | | | | | | | | | | | | | | | |
| 40486 | Bits 5:0 Baud rate, 0x03 ~ 0x0A <table border="1" style="margin-left: 20px;"> <tbody> <tr> <td>Code</td> <td>0x03</td> <td>0x04</td> <td>0x05</td> <td>0x06</td> </tr> <tr> <td>Baud</td> <td>1200</td> <td>2400</td> <td>4800</td> <td>9600</td> </tr> <tr> <td>Code</td> <td>0x07</td> <td>0x08</td> <td>0x09</td> <td>0x0A</td> </tr> <tr> <td>Baud</td> <td>19200</td> <td>38400</td> <td>57600</td> <td>115200</td> </tr> </tbody> </table> Bits 7:6 00: no parity, 1 stop bit 01: no parity, 2 stop bits 10: even parity, 1 stop bit 11: odd parity, 1 stop bit | Code | 0x03 | 0x04 | 0x05 | 0x06 | Baud | 1200 | 2400 | 4800 | 9600 | Code | 0x07 | 0x08 | 0x09 | 0x0A | Baud | 19200 | 38400 | 57600 | 115200 | R/W |
| Code | 0x03 | 0x04 | 0x05 | 0x06 | | | | | | | | | | | | | | | | | | |
| Baud | 1200 | 2400 | 4800 | 9600 | | | | | | | | | | | | | | | | | | |
| Code | 0x07 | 0x08 | 0x09 | 0x0A | | | | | | | | | | | | | | | | | | |
| Baud | 19200 | 38400 | 57600 | 115200 | | | | | | | | | | | | | | | | | | |
| 40488 | Modbus response delay time in ms, valid range: 0 ~ 30 | R/W | | | | | | | | | | | | | | | | | | | | |

| Address | Description | Attribute |
|----------------|--|------------------|
| 40489 | Host watchdog timeout value, 0 ~ 255, in 0.1s | R/W |
| 40490 | Channel enable/disable, 000h ~ 3FFh | R/W |
| 40491 | Module CJC offset in 0.01 °C | R/W |
| 40492 | Host watchdog timeout count, write 0 to clear | R/W |
| 40493 | CJC update setting, 0 ~ 2 | R/W |
| 00257 | Protocol, 0: DCON, 1: Modbus RTU | R/W |
| 00259 | Filter setting, 0: 60Hz rejection, 1: 50Hz rejection | R/W |
| 00260 | Modbus host watchdog mode 0: same as I-7000 1: can use AO and DO command to clear host watchdog timeout status | R/W |
| 00261 | 1: enable, 0: disable host watchdog | R/W |
| 00268 | 1: enable, 0: disable CJC | R/W |
| 00269 | Modbus data format, 0: hex, 1: engineering | R/W |
| 00270 | Host watch dog timeout status, write 1 to clear host watch dog timeout status | R/W |
| 00272 | Write 1 to load factory calibration parameters | W |
| 00273 | Reset status, 1: first read after powered on, 0: not the first read after powered on | R |
| 00276 | Open thermocouple detection, 1: enable, 0: disable | R/W |

Notes:

1. The max number of analog output registers written in a command is 11.
2. The command of loading factory calibration parameters takes about 3 seconds. The next command should be sent after 3 seconds.

3.5 Engineering Data Format Table

| Type Code | Input Type | Min. | Max. |
|-----------|--|--------|-------|
| 00 | -15 mV ~ +15 mV | -15000 | 15000 |
| 01 | -50 mV ~ + 50 mV | -5000 | 5000 |
| 02 | -100 mV ~ +100 mV | -10000 | 10000 |
| 03 | -500 mV ~ +500 mV | -5000 | 5000 |
| 04 | -1 V ~ +1 V | -10000 | 10000 |
| 05 | -2.5 V ~ +2.5 V | -25000 | 25000 |
| 06 | -20 mA ~ +20 mA | -20000 | 20000 |
| 07 | +4 mA ~ +20 mA | 4000 | 20000 |
| 08 | -10 V ~ +10 V | -10000 | 10000 |
| 09 | -5 V ~ +5 V | -5000 | 5000 |
| 0A | -1 V ~ +1 V | -10000 | 10000 |
| 0B | -500 mV ~ +500 mV | -5000 | 5000 |
| 0C | -150 mV ~ +150 mV | -15000 | 15000 |
| 0D | -20 mA ~ +20 mA | -20000 | 20000 |
| 0E | Type J Thermocouple | -2100 | 7600 |
| 0F | Type K Thermocouple | -2700 | 13720 |
| 10 | Type T Thermocouple | -2700 | 4000 |
| 11 | Type E Thermocouple | -2700 | 10000 |
| 12 | Type R Thermocouple | 0 | 17680 |
| 13 | Type S Thermocouple | 0 | 17680 |
| 14 | Type B Thermocouple | 0 | 18200 |
| 15 | Type N Thermocouple | -2700 | 13000 |
| 16 | Type C Thermocouple | 0 | 23200 |
| 17 | Type L Thermocouple | -2000 | 8000 |
| 18 | Type M Thermocouple | -20000 | 10000 |
| 19 | Type L _{DIN43710} Thermocouple | -2000 | 9000 |
| 1A | 0 ~ +20 mA | 0 | 20000 |
| 1B | -150 V ~ +150 V | -15000 | 15000 |
| 1C | -50 V ~ +50 V | -5000 | 5000 |

The under range value is -32768 and the over range value is $+32767$. For the hex data format, please refer to Section 1.11.

4. Troubleshooting

If you are having difficulty using the I-7000 or M-7000 module, here are some suggestions that may help. If you cannot find the answers you need in these guides, contact ICP DAS Product Support. Contact information is located in Section 1.14.

4.1 Communicating with the module

If you attempt to communicate with the module and receive no response, first check the following:

- Make sure the supplied power is within the range of +10 to +30 V DC. If the supplied power is OK, then the power LED should be on.
- Ensure that the RS-485 converter provides the bias. The RS-485 converters manufactured by ICP DAS all provide the bias. Some of the modules can be set to provide the RS-485 bias. For these modules, you can refer to section 1.7 to open the cover to adjust the jumper to enable the RS-485 bias.
- When the module receives a command, the power LED is set to “off”. The power LED is shown as “on” after the module responds. This method can be used to check whether the module has received a command sent from the host.
- If possible, use another device to check whether the host can communicate with the device through the same RS-485 network.
- If the host is a PC installed with a Windows operating system, then execute the DCON Utility to determine whether the module can be found. The DCON Utility can be downloaded from the ICP DAS website <http://www.icpdas.com>. The DCON Utility documentation can be found in the “**Getting Started For I-7000 Series Modules**” manual.
- Set the module to “INIT mode” and communicate with the module using the following settings: address 00, Baud Rate 9600bps, no checksum and DCON protocol. See Section A.1 for details.

4.2 Reading Data

If the data read from the input channel is not correct, first check the following:

- Make sure the type code and data format settings are correct. For I-7017, I-7018, M-7017 and M-7018 series modules, the type code is set by using the %AANNTCCFF command, see Section 2.1 for details. For I-7017Z, M-7017Z, I-7018Z, M-7018Z, I-7019 and M-7019 series modules, the type code is set by using the \$AA7CiRrr command, see Section 2.15 for details. The data format is set by using the %AANNTCCFF command. For the Modbus RTU protocol, the type code is set by using sub-function 08h of the function 46h.
- If the voltage read by the module is incorrect, then it may be because the calibration parameters stored in the non-volatile memory are corrupted. You can calibrate the module by yourself. Be sure to read Section 1.10 in detail before doing any calibration. For I-7019 and M-7019 series modules, use the \$AAS1 command to reload the factory calibration parameters, see Section 2.28 for details.

A. Appendix

A.1 INIT Mode

Each I-7000 and M-7000 module has a built-in EEPROM to store configuration information such as module address, type code, Baud Rate, etc. Occasionally, the configuration of a module may be forgotten and there are no visual indications of the configuration of the module. It is difficult to communicate with the module when the configuration of the module is unknown. To help avoid this problem, the I-7000 and M-7000 series has a special mode called “**INIT mode**”. When the module is powered on in “**INIT mode**” the configuration of the module is reset as follows, allowing it to be operated as normal.

1. Address: 00
2. Baud Rate: 9600 bps
3. No checksum
4. Protocol: DCON

The configuration information stored in the EEPROM is not changed and they can be read by sending the \$002(CR) command at 9600bps.

There are commands that require the module to be in INIT mode. They are:

1. %AANNTTCCFF when changing Baud Rate and checksum settings. See Section 2.1 for details.
2. \$AAPN, see Section 2.26 for details.

Originally, the INIT mode is accessed by connecting the INIT* terminal to the GND terminal. For the I-7017 and I-7017F modules, the INIT* terminal is shared with the Vin7- terminal. The JP1 jumper should be set correctly as shown in Section 1.7.1. New I-7000 and M-7000 modules have the INIT switch located on the rear side of the module allow easier access to INIT mode. For these modules, INIT mode is accessed by sliding the INIT switch to the Init position as shown below.

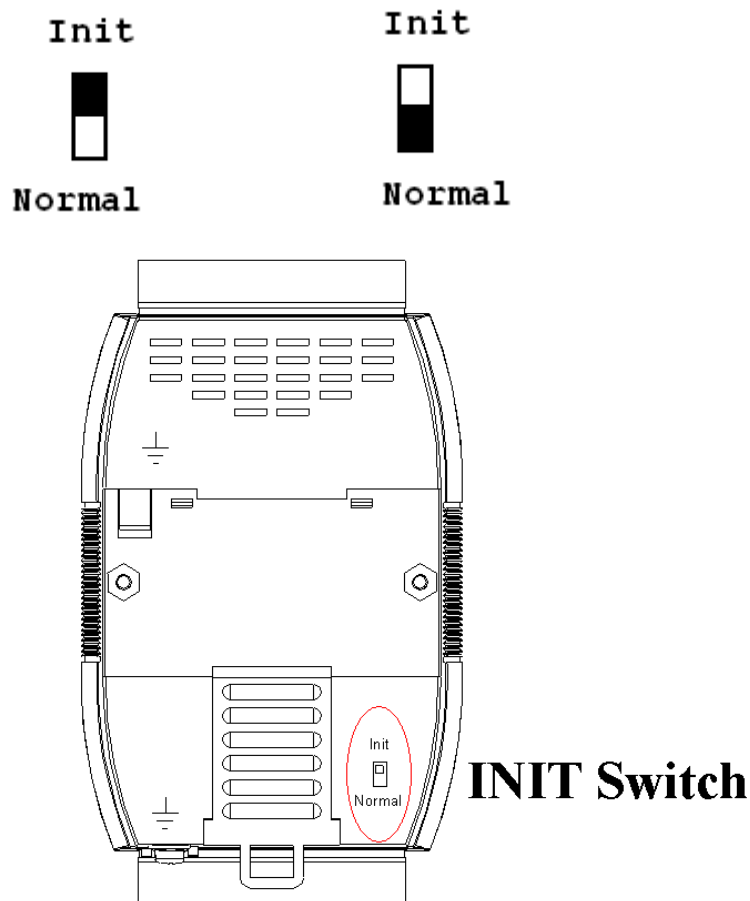

A.2 Dual Watchdog Operation

Dual Watchdog = Module Watchdog + Host Watchdog

The Module Watchdog is a hardware reset circuit that monitors the operating status of the module. While working in harsh or noisy environments, the module may be shut down by external signals. The circuit allows the module to work continuously without disruption.

The Host Watchdog is a software function that monitors the operating status of the host. Its purpose is to prevent problems due to network/communication errors or host malfunctions. When a host watchdog time out occurs, the module will reset all outputs to a safe state in order to prevent any erroneous operations of the controlled target.

I-7000 and M-7000 series modules include an internal Dual Watchdog, making the control system more reliable and stable.

For more information regarding the Dual Watchdog, please refer to Chapter 5 of the “**Getting Started For I-7000 Series Modules**” manual that can be downloaded from the ICP DAS website <http://www.icpdas.com>.

A.3 Thermocouple

When two wires composed of dissimilar homogeneous metals are joined at one end, a thermoelectric electromotive force (emf) appears that depends only on the metals and the junction temperature. This is called the Seebeck effect. A pair of different metals with a fixed junction at one end constitutes a **thermocouple**. For small changes in temperature, the emf is linearly proportional to the temperature. This implies that the temperature reading can be obtained by measuring the emf.

We cannot measure the emf, V_1 , directly because when a voltmeter is connected to the thermocouple, another emf, V_2 , is created at the (cold) junction of the thermocouple and the voltmeter. The cold junction compensation method is used to resolve the problem. Using another sensor, e.g. a thermistor, to measure the cold junction temperature, T_2 , we can calculate the emf, V_2 , which corresponds to T_2 . The thermocouple emf, V_1 , can be obtained by adding V_2 to that measured by the voltmeter and then the temperature.

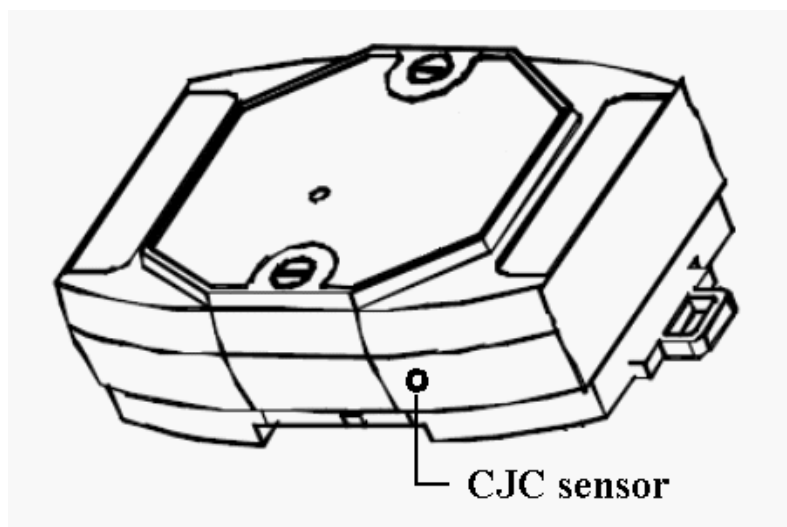

A.4 Frame Ground

Electronic circuits are constantly vulnerable to ESD which become worse in a continental climate area. Some I-7000, and all M-7000, modules feature a new design for the frame ground. The frame ground provides a path for bypassing ESD, which provides enhanced static protection (ESD) abilities and ensures the module is more reliable.

Either of the following options will provide a better protection for the module:

1. If the module is DIN rail mounted, connect the DIN rail to the earth ground because the DIN rail is contacted with the upper frame ground as shown in the figure below.
2. Alternatively, connect the lower frame ground terminal, as shown in the figure below, to a wire and connected the wire to the earth ground.

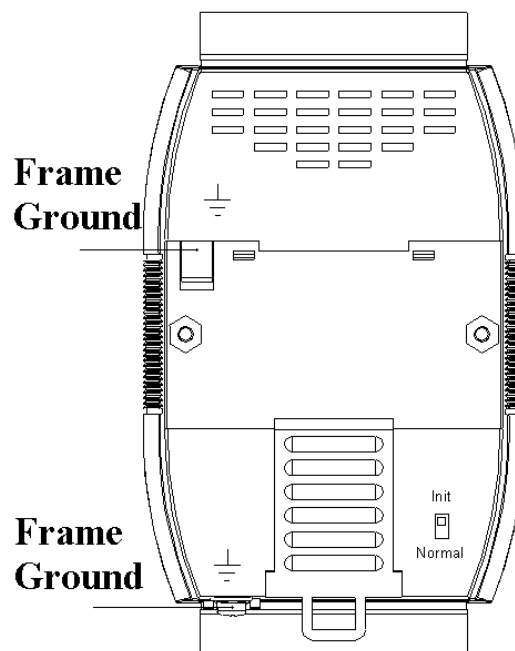

New DIN rail models are available that can easily be connected to the earth ground. Each are made of stainless steel, which is stronger than those made of aluminum. There is a screw at one end and a ring terminal is included as shown in the figure below. Refer to Section 1.13.1 for more information about the new DIN rail models.

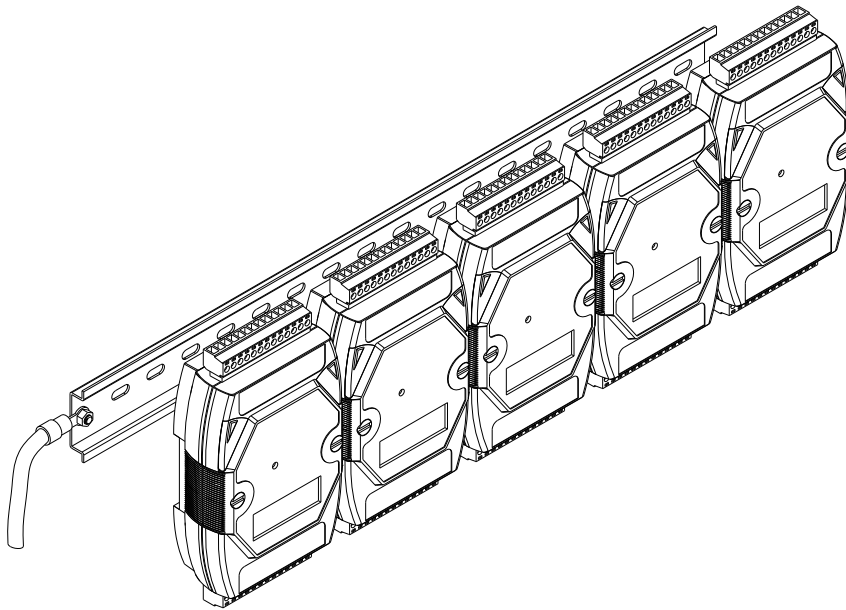

A.5 Hexadecimal Data Conversion

There are two types for hexadecimal data conversion, one for the 4 to 20mA and the 0 to 20mA ranges, and the other for other ranges.

I. for the 4 to 20mA and the 0 to 20mA ranges

The mappings are 0000h maps to the minimum value and FFFFh maps to the maximum value. The formula for the data conversion is

$$\text{real_data} = \text{hex_data} * (\text{max_value} - \text{min_value}) / 65535 + \text{min_value}$$

For example, for the 4 to 20mA range, the formula is

$$\text{real_data} = \text{hex_data} * (20.0 - 4.0) / 65535 + 4.0$$

II. for other ranges

The mappings are 8000h, -32768, maps to -MAX, 0000h, 0, maps to 0, and 7FFFh, 32767, maps to +MAX, where MAX is the larger absolute value of the minimum value and the maximum value. The formula for the data conversion is

If $\text{hex_data} \geq 0$ then

$$\text{real_data} = \text{hex_data} * \text{MAX} / 32767$$

else

$$\text{real_data} = \text{hex_data} * \text{MAX} / 32768$$

For example, for type K thermocouple, -270 ~ 1372°C,

MAX = 1372, the formula is

If $\text{hex_data} \geq 0$ then

$$\text{real_data} = \text{hex_data} * 1372.0 / 32767$$

else

$$\text{real_data} = \text{hex_data} * 1372.0 / 32768$$

Revision History

| Revision | Date | Changes Made |
|----------|------------|--|
| B2.9 | 2018/11/16 | Add section 1.7.2 |
| B3.0 | 2019/1/28 | Add Modbus register 00276 to M-7018Z |
| B3.1 | 2019/3/12 | Modify section 1.3 CMR/NMR |
| B3.2 | 2019/4/3 | Add section 1.7.3 |
| B3.3 | 2020/3/31 | Modify section 1.7 and 4.1 to include RS-485 bias setting |
| B3.4 | 2020/6/30 | Modify section 1.10 to include M-7017mC-16. Fix typo of section 2.8. |
| B3.5 | 2020/12/9 | Modify section 1.3 to specify accuracy as of FSR. |
| B3.6 | 2020/12/22 | Modify section 1.3 to change M-7017mC-16 fast mode accuracy to 0.2% |