

CAN-2057D Quick Start

Packing List

CAN-2057D



CD



Screw Driver



Quick Start

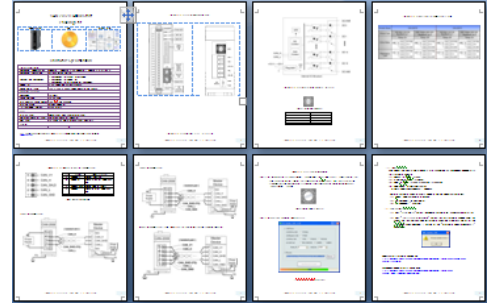

Hardware Specification

CAN Interface	
DeviceNet Specification	Volume I, Release 2.0 & Volume II, Release 2.0, Errata 5
DeviceNet Subscribe	Group 2 Only Server
Supported Connection	1 connection for Explicit Messaging 1 connection for Polled I/O 1 connection for Bit-Strobe I/O connection
Node ID	0~63 selected by rotary switch
Baud Rate (bps)	125 k, 250 k, 500 k, selected by rotary switch
Digital Output	
Channels	16(Sink)
Load Voltage	+5~30 V _{DC}
Output Max. Load Current	700 mA per channel
Output Type	Open Collector
Intra-module Isolation	3750 V _{rms}
LED	
Status LED	PWR LED, NET LED, MOD LED
Terminal Resister LED	Terminal Resister Indicator
DO LED	16 LEDs as Digital Output LED Indicators
Power	
Input range	Unregulated +10 ~ +30 V _{DC} , 1.5 W

For more information about CAN-2057D, please visit the following website:

[CAN-2057D](#)

CAN-2057D Pin Assignments

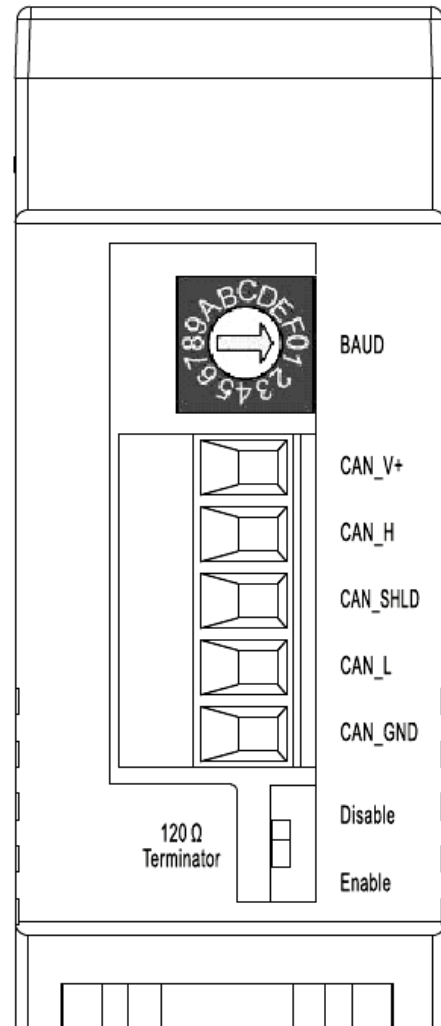
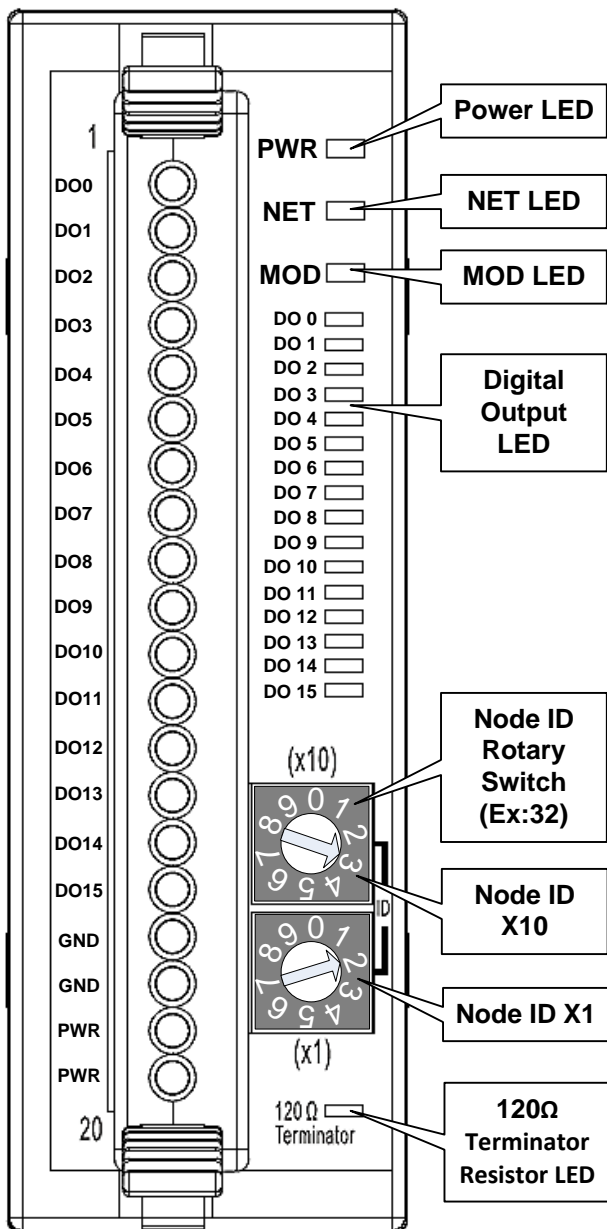

CAN-2057D Internal I/O Structure

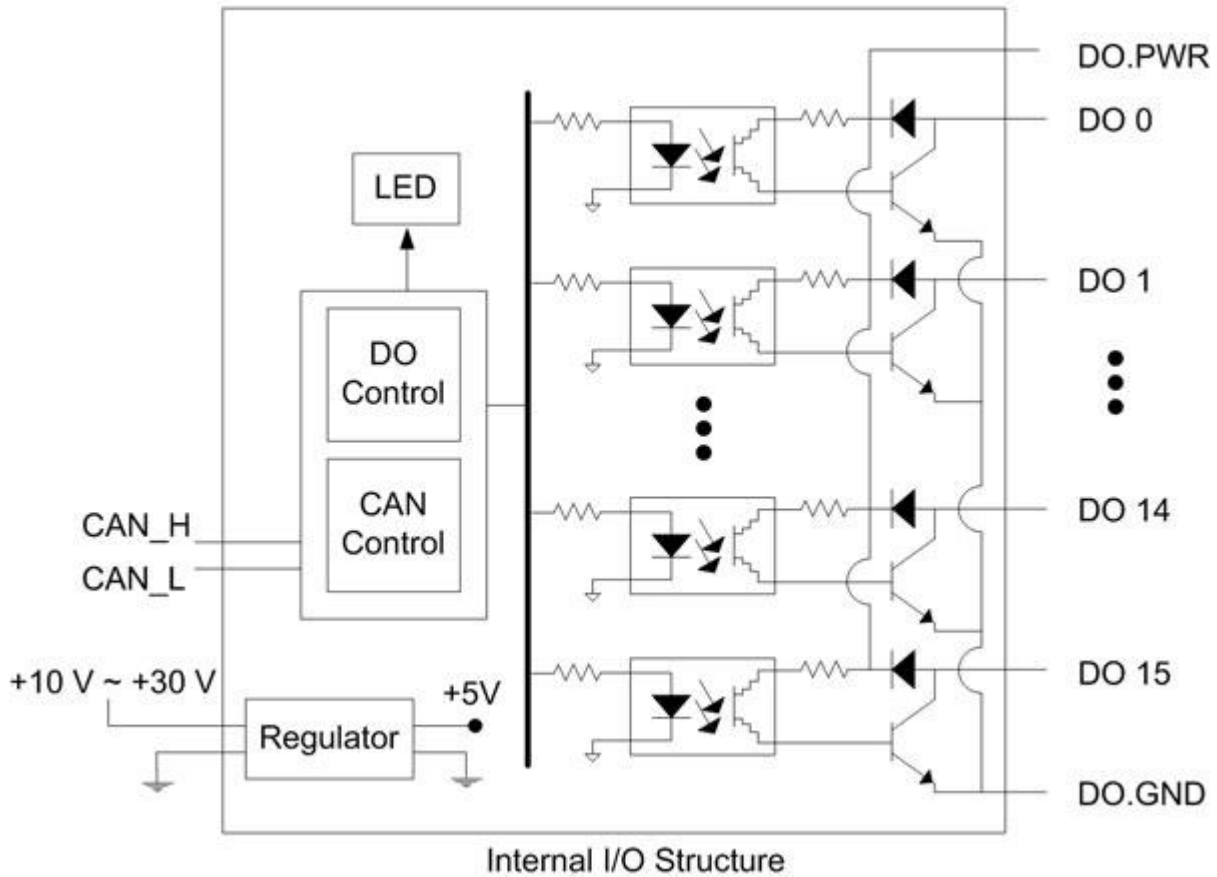

CAN-2057D Baud Rate Rotary Switch

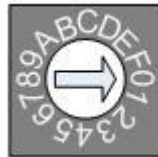

Baud rate rotary switch

Rotary Switch Value	Baud rate (kbps)
0x0	125
0x1	250
0x2	500
0xF	Firmware update

CAN-2057D Wiring Connection Type

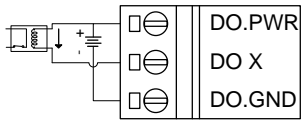
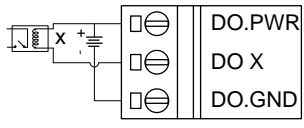
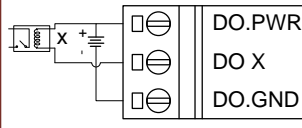
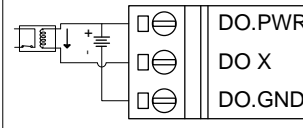
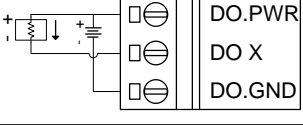
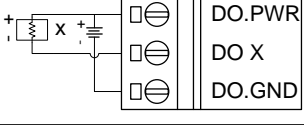
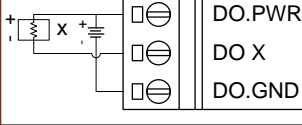
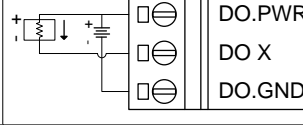
Module Name	CAN-2057D		CAN-2057C	
Output Type	ON State LED ON Readback as 1	OFF State LED OFF Readback as 0	ON State LED ON Readback as 1	OFF State LED OFF Readback as 0
Drive Relay	Relay On	Relay Off	Relay Off	Relay On
Resistance Load	Relay On	Relay Off	Relay Off	Relay On
Drive Relay				
Resistance Load				

CAN-2057D CAN Bus Wire Connection

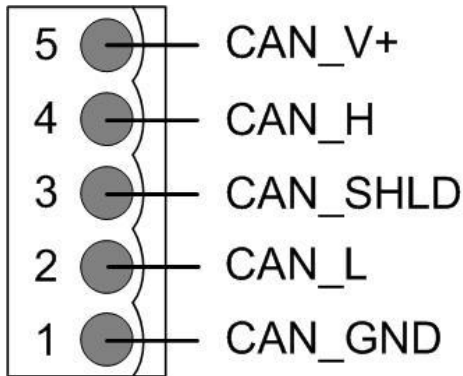

Pin	Signal	Description
5	CAN_V+	Power positive
4	CAN_H	Signal high of CAN Bus line
3	CAN_SHLD	Cable Shield (FG)
2	CAN_L	Signal low of CAN Bus line
1	CAN_GND	CAN ground

* CAN_SHLD (FG) is Optional.

2-Wire Connection

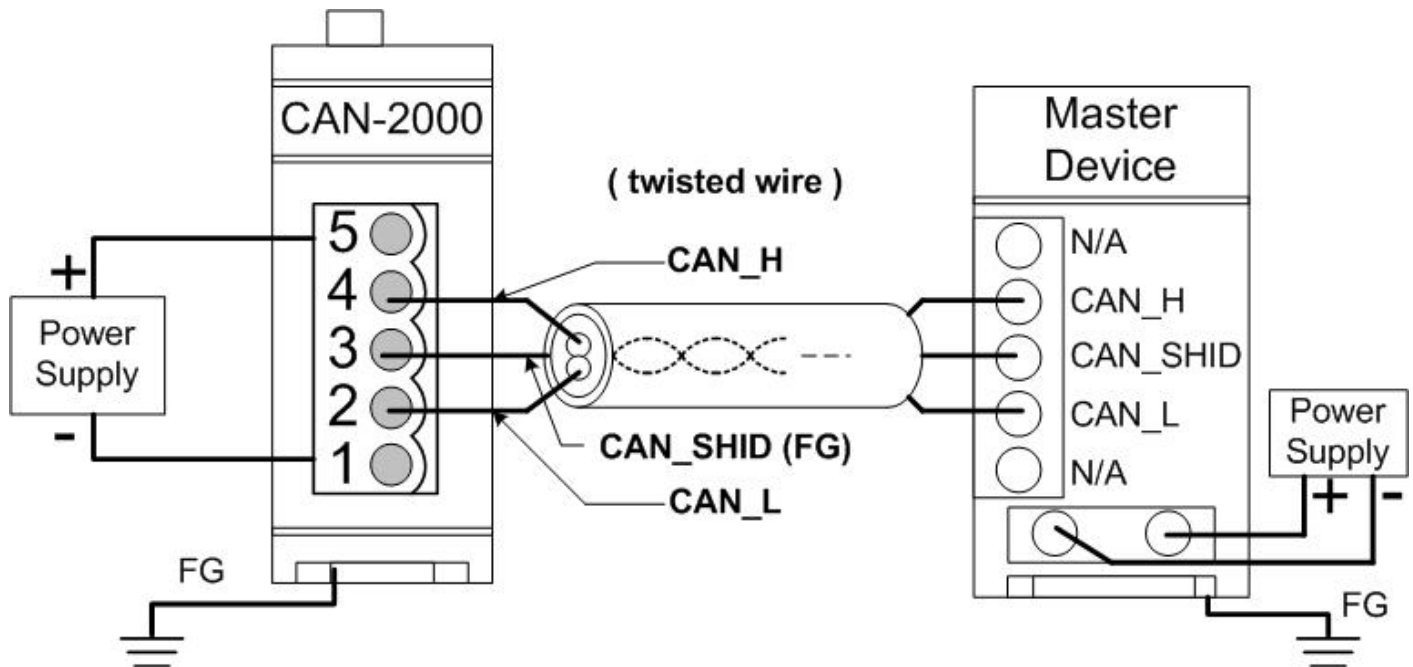

3-Wire Connection

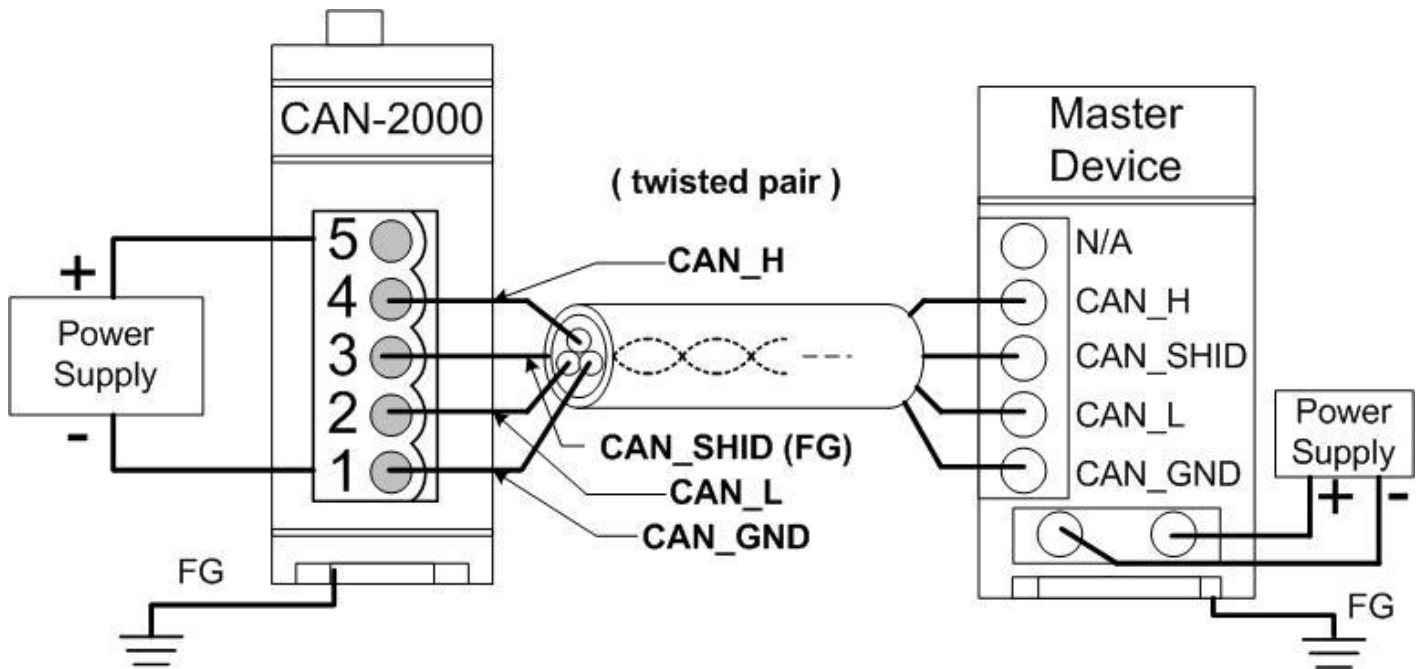

4-Wire Connection (The CAN-2000 is powered by the master device)

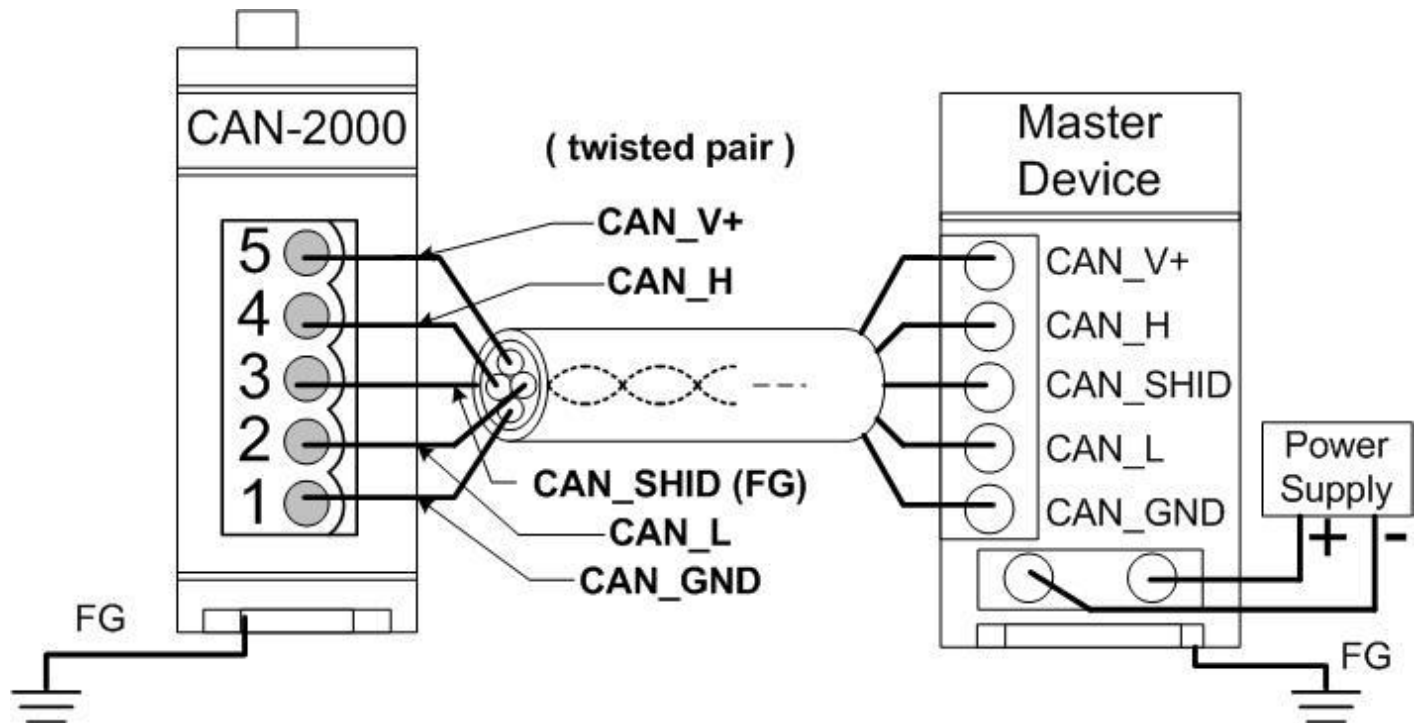

CAN-2057D Firmware Update

Step 1 – Set Module to “Bootloader” mode (set baud rate to 0xF). Then power on the module. After power on, the module’s led(PWR, NET, MOD) will be flashed at the same time. It means that the module have entered into “Bootloader” mode.

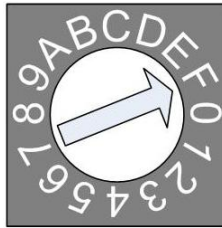

Baud Rate Rotary Switch

Step 2 – Run FW_Update_CAN Utility

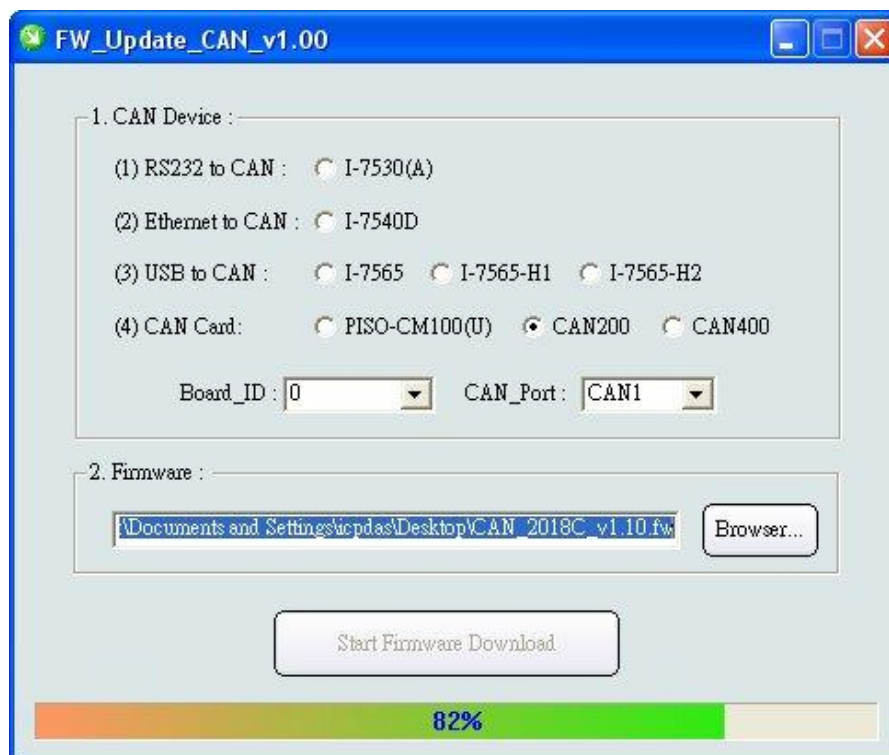

(FW_Update_CAN Utility)

[1] CAN Device :

The below ICP DAS CAN products are supported by FW_Update_CAN utility for firmware update.

- (1) RS232 to CAN : I-7530
- (2) Ethernet to CAN : I-7540D
- (3) USB to CAN : I-7565, I-7565-H1, I-7565-H2
- (4) CAN Card : PISO-CM100(U),
PISO-/PCM-/PEX-CAN200 / CAN400

Before firmware update, users need to set the below parameters.

- (1) Select CAN hardware interface
- (2) set Dev_Port or Board_ID
- (3) set CAN_Port” number

[2] Download Firmware :

- (1) Click “**Browser...**” button to choose firmware file, can_2057d_vX.X.fw.
- (2) Click “**Start Firmware Update**” button to start firmware update and it will show the total percentage of firmware update in progress bar. After the firmware update finished, it will show the “Firmware Update Success !!” message.

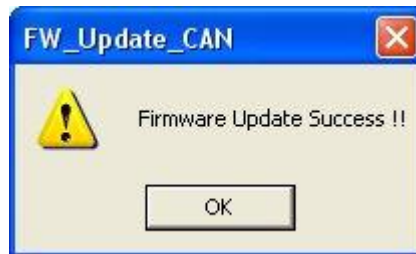

CAN-2057D firmware Download:

ftp://ftp.icpdas.com.tw/pub/cd/fieldbus_cd/devicenet/slave/can-2000d/can-2057d/firmware/

FW_Update_CAN Utility Download:

ftp://ftp.icpdas.com.tw/pub/cd/fieldbus_cd/devicenet/slave/can-2000d/tools/fw_update_can_tool/