



## Packing List

In addition to this guide, the package includes the following items:



I-7531-FD /  
I-7531-FD-UTA



Plastic rail

## Technical Support

[service@icpdas.com](mailto:service@icpdas.com)

[www.icpdas.com](http://www.icpdas.com)

## Resources

How to search for drivers, manuals and spec information on ICP DAS website.

- For Mobile Web

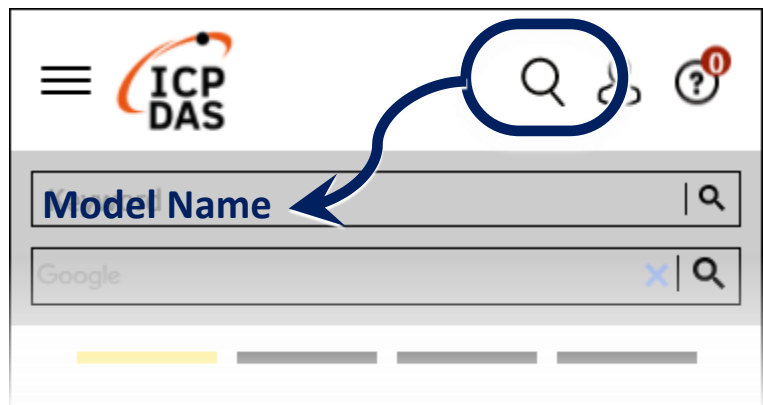

- For Desktop Web



ModelName | Q

Google

X | Q



PRODUCTS SOLUTIONS NEWS & EVENTS SUPPORT CORPORATE

# 1. Appearance

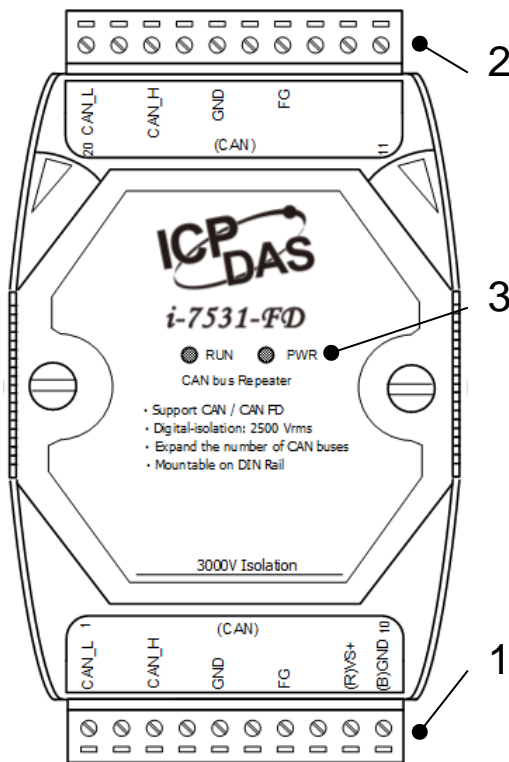

Number	Description
1	CAN port 1
2	CAN port 2
3	LED indicators

# 2. LED indicators

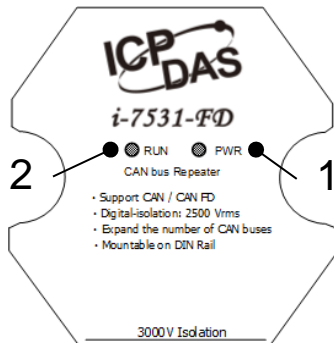

LED	Color	Status	Description
1 (PWR)	Red	ON	Power on
		OFF	Power off
2 (RUN)	Green	Blink	In communication
		OFF	No data in communication

Note 1: Twinkling rate correlates of RUN LED with baud rate of CAN bus. Users may see no twinkling when the twinkling period is too short because of the higher baud rate of CAN bus. Besides, the LED could look like always on when bus loading is heavy.

### 3. Pin assignments

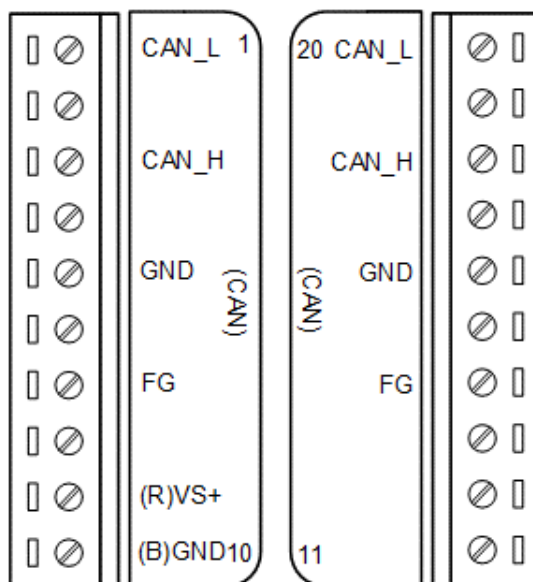

Pin	Name	Description
1	CAN_L	CAN_Low. Signal Line of CAN port 1.
3	CAN_H	CAN_High. Signal Line of CAN port 1.
5	GND	CAN_Ground (or CAN_GND), voltage level of ground of CAN_L and CAN_H in CAN port 1.
7	FG	Frame Groud.
9	(R)VS+	Power input +10VDC ~ +30VDC.
10	(B)GND	
14	FG	Frame Groud.
16	GND	CAN_Ground (or CAN_GND), Voltage level of ground of CAN_L and CAN_H in CAN port 2.
18	CAN_H	CAN_High. Signal Line of CAN port 2.
20	CAN_L	CAN_Low. Signal Line of CAN port 2.

## 4. Terminator Resistor Setting

The JP1 of I-7531-FD is used for adjusting terminal resistor (120Ω) on CAN Port 1, and the JP2 for CAN Port 2. If the user want to adjust the terminal resistor that need to open the cover of I-7531-FD, and will see the locations of JP1 and JP2 are shown as following figure:

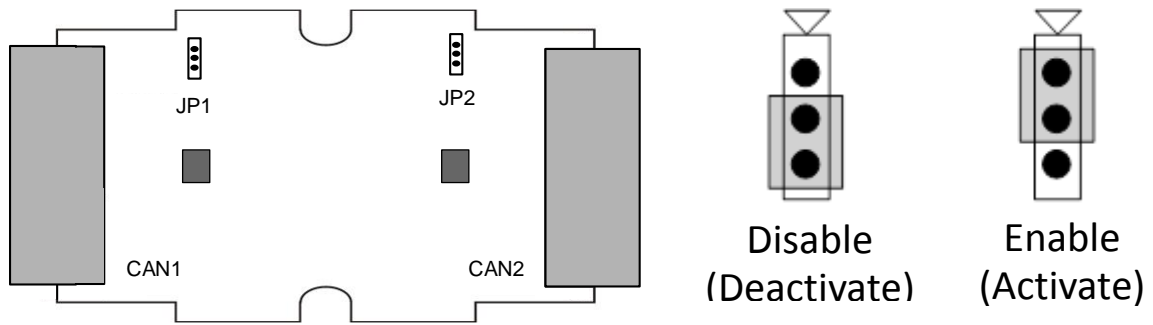

## 5. Wire Connections

