

I-8092F Getting Started Manual

(Version 2.3)

Hardware & Software & Application
Using I-8092F PAC Motion Control Module



ICP DAS CO., LTD.

泓格科技股份有限公司

Warranty

All products manufactured by ICPDAS Inc. are warranted against defective materials for a period of one year from the date of delivery to the original purchaser.

Warning

ICPDAS Inc. assumes no liability for damages consequent to the use of this product. ICPDAS Inc. reserves the right to change this manual at any time without notice. The information furnished by ICPDAS Inc. is believed to be accurate and reliable. However, no responsibility is assumed by ICPDAS Inc. for its use, or for any infringements of patents or other rights of third parties resulting from its use.

Copyright

Copyright 1997-2005 by ICPDAS Inc., LTD. All rights reserved worldwide.

Trademark

The names used for identification only maybe registered trademarks of their respective companies.

License

The user can use, modify and backup this software on a single machine. The user may not reproduce, transfer or distribute this software, or any copy, in whole or in part.

Contents of I8092F

1 INTRODUCTION.....	6
1.1 Introduction.....	6
1.2 Hardware Specification	7
1.2.1 Main Specification	7
1.2.2 Interpolation Function.....	7
1.2.3 Pulse Output.....	7
1.2.4 Encoder Input.....	8
1.2.5 Position counter.....	8
1.2.6 Servo Motor Input Signal.....	8
1.2.7 Limit Switch Input Signal	8
1.2.8 Other Input Signals.....	8
1.2.9 Emergency Stop Signal Input	9
1.2.10 General Output Signal.....	9
1.2.11 Integral Input Signal Filters	9
1.2.12 Software Limit.....	9
1.2.13 Manual Pulse Generator	9
1.2.14 LED for Module status	9
1.2.15 FRnet	9
1.3 Environment.....	10
1.4 Ordering Information.....	10
2 HARDWARE INSTALLATION.....	11
2.1 Checking Package and Installation.....	11
2.1.1 Checking package.....	11
2.1.2 Installation	11
2.2 DN-8237-GB Daughter Board	12
2.2.1 Board Layout for DN-8237-GB	12
2.2.2 Signal Connections for DN-8237-GB.....	13
2.2.3 Jumper and Switch Settings	17
2.3 Input/Output Connections	20
2.3.1 Pulse output signals	20
2.3.2 Connection for Limit switch Signal.....	22
2.3.3 General Purpose Input Signals(nINPOS,nALARM).....	22
2.3.4 Encoder Signals	23
2.3.5 Emergency Stop Signal	23

2.3.6 Manual Pulse Generator Input Signal (EXP+,EXP-)	24
2.3.7 General Purpose Output signals(Servo On/Off)	24
2.4 Connection Example for Motor Driver	25
3 SOFTWARE DEVELOPMENT OVERVIEW	26
3.1 Software development Overview	26
3.1.1 Register Module	27
3.2 Safety IO Setting	27
3.2.1 Emergency Stop Signal Input	27
3.2.2 Configure the Servo ALARM Signals	27
3.2.3 Configure the Limit Switch Signals(\pm EL)	27
3.2.4 Configure the Software Limite(\pm SEL)	28
3.3 Error Checking	28
3.4 Basic Configuration of Motion	28
3.5 Manual Pulse Generator Testing	29
3.6 Home Search	30
3.6.1 Home Search Configuration	30
3.7 Basic Motion	32
3.7.1 Speed Profile of the Motion Control	32
3.7.2 Basic Setting of Single Axis	33
3.7.3 Basic Motion of Single Axis	34
3.7.4 Basic Setting of Muti-Axes Interpolation	34
3.7.5 Basic Motion of Muti-Axes Interpolation	35
3.8 Advance Motion	35
4 GETTING STARTED OF SOFTWARE	37
4.1 WinCon eVC++ Guideline	37
4.1.1 Confirm the Relative Files	37
4.1.2 Create a new eVC++ Application Project	37
4.1.3 Add the I8094.h into eVC++ Application Project	39
4.1.4 Add the Reference Path into eVC++ Application Project	40
4.1.5 Start the eVC++ Sample	41
4.1.6 Build the Project	44
4.1.7 Download and Run	45
4.2 Microsoft Visual Studio .NET 2003(VB.NET , C#) Guideline	46
4.2.1 Confirm the Relative Files	46
4.2.2 Create a new VB.NET/C# Application Project	46

4.2.3 Add the DLL into Application Project.....	48
4.2.4 Start the VB.NET/C# Sample	50
4.2.5 Build the Project	53
4.2.6 Download and Run.....	53
4.3 I-8000 Turbo C Guideine.....	53
4.3.1 Confirm the Relative Files	53
4.3.2 Create a new TC ++ Application Project.....	54
4.3.3 Start the TC Sample	56
4.3.4 Build the Project	63
4.3.6 Download and Run.....	63

APPENDIX-A SETUP TOOLS & OTHERS..... 65

A.1 Setup the Development Environment of I8094	65
A.1.1 eVC ++ 4.0.....	65
A.1.2 Visual Studio .NET 2003(VB.NET , C#).....	65
A.1.3 Turbo C	65
A.2 I8094 Surface.....	66
A.3 Dimensions.....	67
A.4 The Version Upgrades Note.....	67

APPENDIX B OTHER TERMINAL BOARDS..... 68

B.1 DN-8237-DB Daughter Board.....	68
B.1.1 Board Layout for DN-8237-DB	68
B.1.2 Signal Connections for DN-8237-DB	69
B.1.3 Jumper and Switch Settings.....	74
B.2 DN-8237-MB Daughter Board	77
B.2.1 Board Layout for DN-8237-MB.....	77
B.2.2 Signal Connections for DN-8237-MB	78
B1.3 Jumper and Switch Settings.....	85
B.3 DN-8237-PB Daughter Board	87
B.3.1 Board Layout for DN-8237-PB	87
B.3.2 Signal Connections for DN-8237-PB.....	88
B.3.3 Jumper and Switch Settings.....	93
B.4 DN-8237-YB Daughter Board.....	95
B.4.1 Board Layout for DN-8237-YB	95
B.4.2 Signal Connections for DN-8237-YB.....	96
B.4.3 Jumper and Switch Settings.....	101

1 INTRODUCTION

1.1 Introduction

The I-8092F are the 2-axis pulse-type stepping/servo motor motion control module that can be used on any of the ICPDAS I-8000, WinCon and LinCo series controllers, and is suitable for general-purpose motion application. These modules contain a high-performance motion ASIC. Apart from a wide speed range, these intelligent motion controllers have a variety of motion control functions built in, such as 2-axis linear interpolation, 2-axis circular interpolation, T/S-curve acceleration/ deceleration, automatic homing, and others. Besides, it is a module that has full functions of I-8092F plus one port of FRnet. The FRnet port allows this module to expand its fast remote I/O easily. This two-wired FRnet can automatically scan its 128 DI and 128 DO with a period of 0.72/2.88ms. In addition, most of the I-8092F motion control functions are performed with little load on the processor. While driving the motors, the motion status, and the other I/O status on the I-8000, WinCon, or LinCon controllers, can still be monitored. As a result of the low CPU loading requirements of I-8092F, one or more motion modules may be used on a single I-8000, WinCon, or LinCon controllers. ICPDAS also has provided a wide range of functions and examples to reduce the need for programming by user, making it a highly cost-effective solution for machine makers.

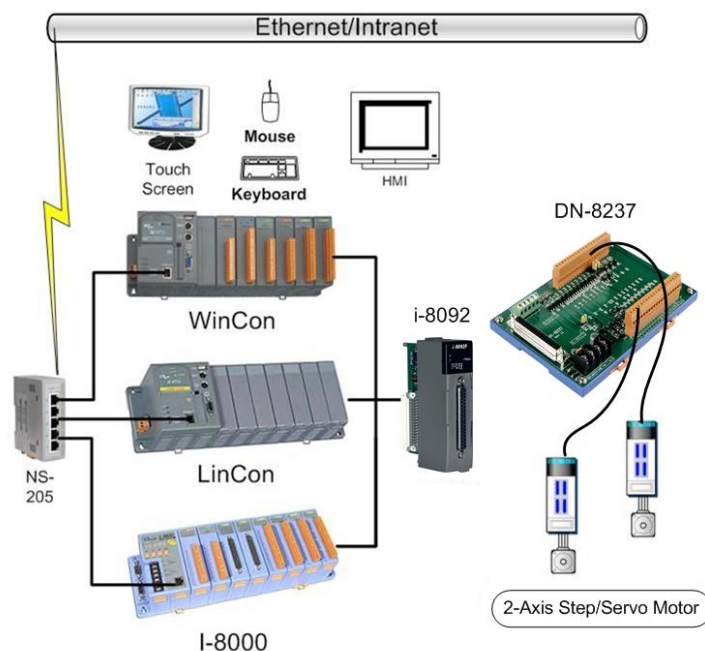

18092f with PAC controller (WinCon-8000、LinCon-8000、I-8000)

1.2 Hardware Specification

1.2.1 Main Specification

- ASIC Chip MCX312
- Number of controllable 2-axis, Pulse output (stepping & servo motor)
- Up to 4M PPS pulse output

1.2.2 Interpolation Function

2-axis linear interpolation

- Interpolation range -8,388,607 ~ +8,388607
- Vectors speed of interpolation 1 PPS ~ 4M PPS
- Precision of interpolation ± 0.5 LSB

Circular interpolation

- Interpolation range -8,388,607 ~ +8,388607
- Vectors Speed of interpolation 1 PPS ~ 4M PPS

Bit interpolation

- Vectors Speed of interpolation 1 PPS ~ 4M PPS(Dependent on CPIU data writing time)

Relative interpolation function

- Fixed vectors speed
- Continuous interpolation

1.2.3 Pulse Output

- Output speed range 1 PPS ~ 4 MPPS
- Output precision $\pm 0.1\%$
- Jerk range of S-curve 954 ~ 62.5×10^6 PPS/S²
477 x 10³ ~ 31.25×10^9 PPS/S²
- Acceleration/deceleration range 125 ~ 1×10^6 PPS/S
 62.5×10^3 ~ 500×10^6 PPS/S
- Speed precision 1 PPS ~ 500PPS(Depend on the max.speed)
- Output numbers 0 ~ 4,294,967,295 / unlimited
- Velocity profiles mode:
 - ◆ Fixed
 - ◆ Symmetrical & Asymmetrical Trapezoidal velocity profile

- ◆ Symmetrical & Asymmetrical S-curve velocity profile
- Acceleration & Deceleration mode
 - ◆ Auto
 - ◆ By user define
- Position & Speed change on the fly
- Fixed pulse output by Trapezoidal and S-curve velocity profile
- Pulse output option: CW/CCW, PULSE/DIR
- Programmable logic level (Rising Edge/ Falling Edge)

1.2.4 Encoder Input

- Encoder option: A/B phase, Up/Down
- Programmable A/B phase mode: 1, 1/2, and 1/4 A/B phase
- Programmable direction of counter

1.2.5 Position counter

- Command counter range -2,147,483,648 ~ +2,147,483,647
- Encoder counter range -2,147,483,648 ~ +2,147,483,647
- Programmable ring counter
- Programmable direction of counter
- Programmable read & write counter

1.2.6 Servo Motor Input Signal

- Alarm
- Choose IN2: In Position or Servo Ready signal
- Choose input signal: Enable/Disable and logical level.

1.2.7 Limit Switch Input Signal

- Two-limit switch signal for each axis: +Limit, -Limit
- Programmable logic level
- Programmable action mode(slow-down stop or immediately stop)

1.2.8 Other Input Signals

- IN3 : Digital Input of general purpose.

1.3 Environment

- Operating Temp: -20 ~ + 75°C
- Storage Temp: -30 ~ +85°C
- Operating Humidity: 10 ~ 85% , non-condensing
- Storage Humidity: 5 ~ 90% , non-condensing
- I/O optically isolated 2500Vrms
- External Power supply(Input): 24V DC (connect to terminal board)

1.4 Ordering Information

- i8092F 2-axis motion control module
- DN-8237GB For general purpose usage
- DN-8237DB For Delta ASDA Servo motor
- DN-8237MB For Mitsubishi J2 Servo motor
- DN-8237PB For Panasonic minas A4 Servo motor
- DN-8237YB For Yaskawa $\Sigma - \Pi$ Servo motor
- CA-3710DM 37-pin Dsub cable , length:1.0 m
- CA-3730DM 37-pin Dsub cable , length:3.0 m
- CA3750DM 37-pin Dsub cable , length:5.0 m
- 4PCA-SCSI20-M1 20-pin SCSI cable, length: 1.0 m
- 4PCA-SCSI50-D1 50-pin SCSI cable for Delta, length: 1.0 m
- 4PCA-SCSI50-PY1 50-pin SCSI cable for Panasonic and Yaskawa, length: 1.0 m
-

2 HARDWARE INSTALLATION

2.1 Checking Package and Installation

2.1.1 Checking package

- The i8092F are a 2-axis stepping/servo motor control module that can be used on any of the ICPDAS I-8000, WinCon and WinPAC series controllers.

2.1.2 Installation

Prepare controller

1. Choose a PAC controller of ICPDAS (I-8000 or W-8000series) and have empty slot.
2. Turn power off

Module Plug in controller and wiring

1. Plug in the i8092F into a empty slot of I-8000/W-8000.
2. Connect the i8092F with DN-8237 by a CA-3710DM cable, as the below figure:



Figure. i8092F with PAC controller (WinCon-8000 、LinCon-8000 、I-8000)

2.2 DN-8237-GB Daughter Board

The DN-8237-GB is the daughter board for General Purpose Amplifiers. It has 2-axis I/O signals.

2.2.1 Board Layout for DN-8237-GB

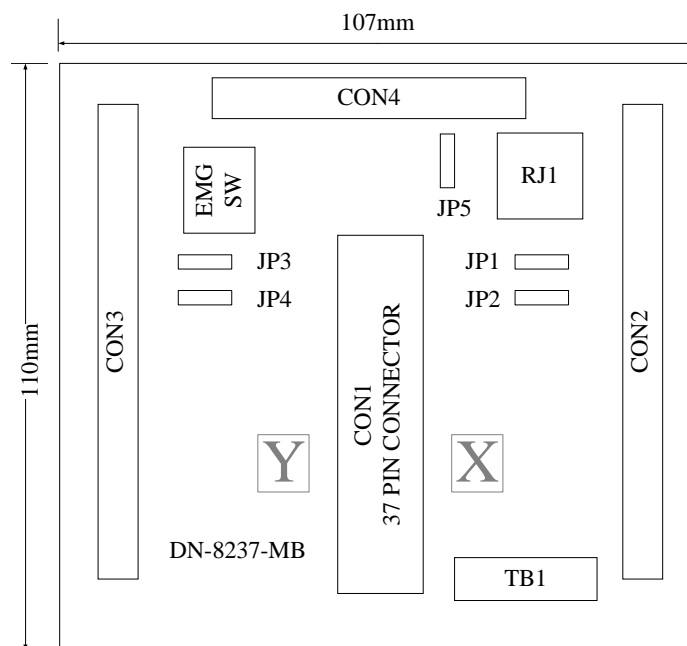

Fig. 2-1 Board layout for the DN-8237-GB

2.2.2 Signal Connections for DN-8237-GB

Maintaining signal connections is one of the most important factors in ensuring that your application system is sending and receiving data correctly.

■ Pin Assignment for CON1

The I/O connector on the DN-8237-GB is a 37-pin connector that enables you to connect to the PISO-PS200(or I-8092F) motion card. Fig. 2-2 shows the pin assignment for the 37-pin I/O connector on the DN-8237-GB (or on the motion card), and refer to Table 2-2 for description of each motion I/O signal.

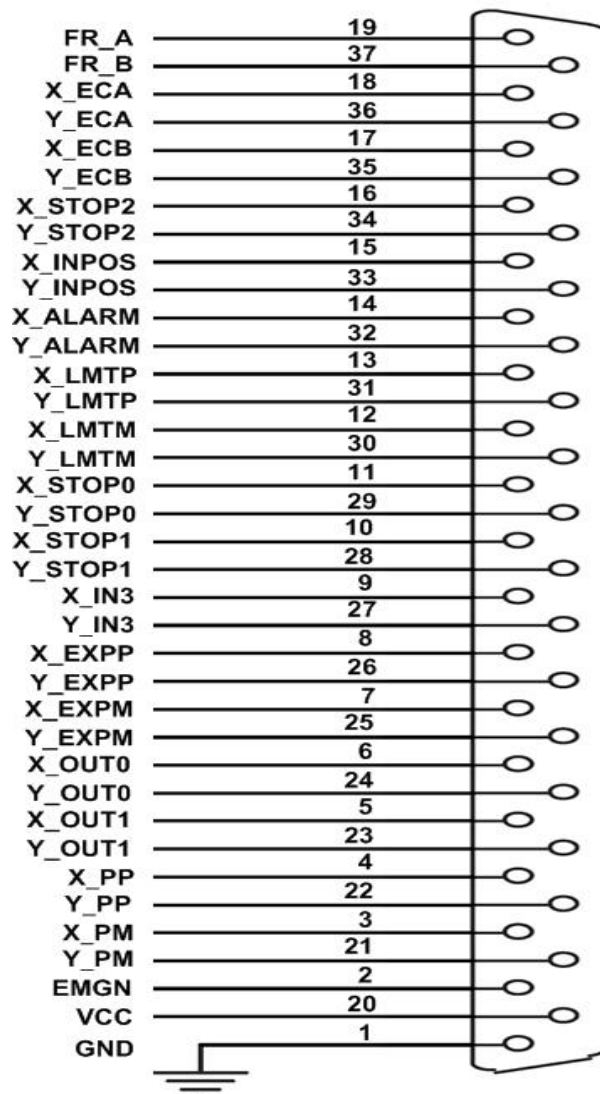

Fig. 2-2 I/O connector pin assignment for the CON1

Table 2-2 DN-8237-MB CON1 I/O connector signal description

Pin name	Pin number	Description
FR_A	19	FRnet A-phase signal
FR_B	37	FRnet B-phase signal
X_ECA	18	Encoder A-phase signal for the X axis
Y_ECA	36	Encoder A-phase signal for the Y axis
X_ECB	17	Encoder B-Phase signal for the X axis
Y_ECB	35	Encoder B-Phase signal for the Y axis
X_STOP2	16	Stop 2 signal for the X axis
Y_STOP2	34	Stop 2 signal for the Y axis
X_INPOS	15	In-position signal for the X axis
Y_INPOS	33	In-position signal for the Y axis
X_ALARM	14	Alarm signal for the X axis
Y_ALARM	32	Alarm signal for the Y axis
X_LMTP	13	Limit switch input signal (+) for the X axis
Y_LMTP	31	Limit switch input signal (+) for the Y axis
X_LMTM	12	Limit switch input signal (-) for the X axis
Y_LMTM	30	Limit switch input signal (-) for the Y axis
X_STOP0	11	Stop 0 signal for the X axis
Y_STOP0	29	Stop 0 signal for the Y axis
X_STOP1	10	Stop 1 signal for the X axis
Y_STOP1	28	Stop 1 signal for the Y axis
X_IN3	9	Input 3 signal for the X axis
Y_IN3	27	Input 3 signal for the Y axis
X_EXPP	8	EXT pulsar input signal (+) for the X axis
Y_EXPP	26	EXT pulsar input signal (+) for the Y axis
X_EXPM	7	EXT pulsar input signal (-) for the X axis
Y_EXPM	25	EXT pulsar input signal (-) for the Y axis
X_OUT0	6	Output 0 signal for the X axis
Y_OUT0	24	Output 0 signal for the Y axis
X_OUT1	5	Output 1 signal for the X axis
Y_OUT1	23	Output 1 signal for the Y axis
XPP	4	Driving pulsar signal (+) for the X axis
YPP	22	Driving pulsar signal (+) for the Y axis
XPM	3	Driving pulsar signal (+) for the X axis
YPM	21	Driving pulsar signal (+) for the Y axis
EMGN	2	Emergency stop input signal
VCC	20	Module power (+5V)
GND	1	Ground

■ CON2 & CON3 (I/O connector for each AXIS)

The connectors CON2 and CON3 are 20-pin connectors that enable you to connect to the I/O signals for general purpose motor drivers. Fig.2-3 shows the pin assignment for the 20-pin connector on the DN-8237-GB, and the Table 2-3 shows its I/O connector signal description.

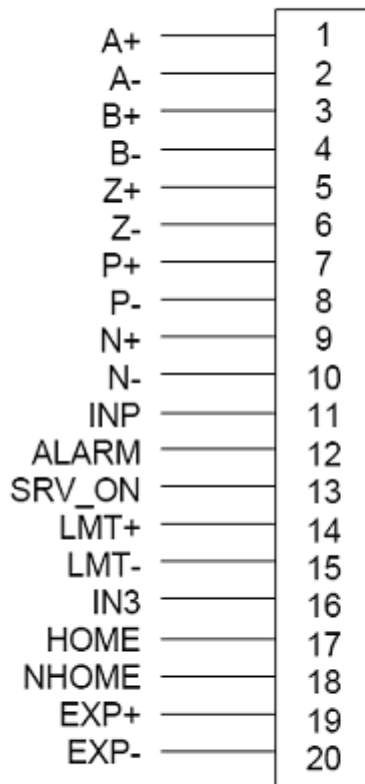

Fig. 2-3 Pin definition for CON2 & CON3

Table 2-3 CON2 ~ CON3 Signal Connection

Name	Number	Description
A+	1	Encoder A-Phase (+)
A-	2	Encoder A-Phase (-)
B+	3	Encoder B-Phase (+)
B-	4	Encoder B-Phase (-)
Z+	5	Encoder Z-Phase (+)
Z-	6	Encoder Z-Phase (-)
P+	7	Positive Direction Pulse Output(+)
P-	8	Positive Direction Pulse Output(-)
N+	9	Negative Direction Pulse Output(+)
N-	10	Negative Direction Pulse Output(-)
INP	11	Servo In Position
ALARM	12	Servo Alarm
SRV_ON	13	Servo On
LMT+	14	Limit Switch Input Signal (+)
LMT-	15	Limit Switch Input Signal (-)
IN3	16	Input Signal (IN3)
HOME	17	Home Sensor Input Signal
NHOME	18	Near Home Sensor Input Signal
EXP+	19	EXT Positive Direction Pulse (+)
EXP-	20	EXT Negative Direction Pulse (-)

■ CON4

The connector CON4 is 16-pin connector that enables you to connect to the signals of your motor drivers. Fig.2-4 shows the pin assignment for the 11-pin connector on the DN-8237-GB, and the Table 2-4 shows its I/O connector signal description.

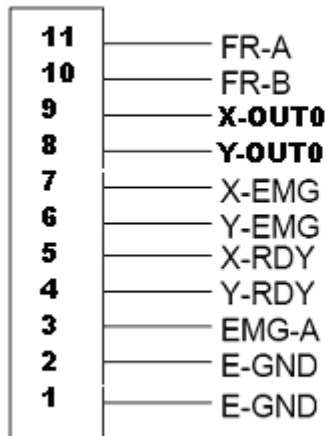

Fig.2-4 Pin definition for CON4

Table 2-4 CON4 Signal Connection

Name	Description
FR-A	FRnet port A
FR-B	FRnet port B
X-OUT0	OUT0 output signal for X axis
Y-OUT0	OUT0 output signal for Y axis
X-EMG	EMG input signal for X axis
Y-EMG	EMG input signal for Y axis
X-RDY	Ready input signal for X axis
Y-RDY	Ready input signal for Y axis
EMG-A	EMG input signal for all axes
E-GND	EXT power ground
E-GND	EXT power ground

■ TB1

The connector TB1 is 5-pin connector that enables you to connect to the signals of your motor drivers. Fig.2-4 shows the pin assignment for the 5-pin connector on the DN-8237-GB, and the Table 2-4 shows its I/O connector signal description.

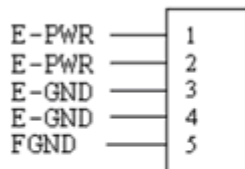

Fig.2-4 Pin definition for TB1

Table 2-4 TB1 Signal Connection

Pin name	Description
E-PWR	EXT power supply +24V
E-GND	EXT power ground
FGND	Frame ground

► **Note:** Don't reverse connect signals with E_PWR and E_GND. Serious damage to your motion card and motion controller might be happened.

■ RJ1 (The I/O signals of the FRnet)

The connectors RJ1 is an 8-pin RJ45 connector that enable you to connect to the signals of FRnet. Fig.3-5 shows the pin assignment for the 8-pin connector on the DN-8237-GB, and the Table 3-5 shows its I/O connector signal description.

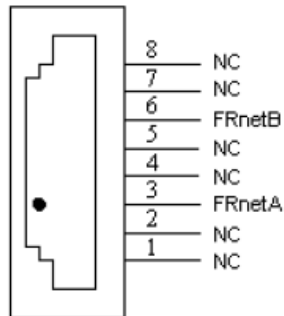

Table 3-5 RJ1

Pin name	Description
FRnetA	FRnet port A
FRnetB	FRnet port B
NC	No connection

Fig. 3-5 Pin definition for RJ1

► **Note:** Don't connect NC (not connected) signals. Connecting these signals could cause permanent damage to your motion controller.

2.2.3 Jumper and Switch Settings

■ JP5

Jumper 5 controls the EMG-A signal of the CON4 connector. The following diagram is shown the selection condition of the jumper 5.

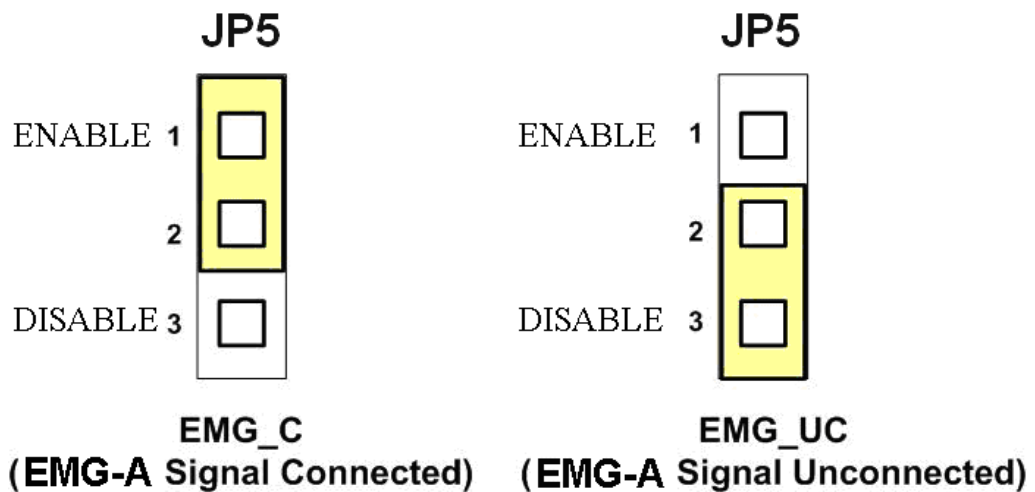

Fig. 3-6 Jumper 5 setting

■ SW 1

The emergency stop signal for each servo amplifier can be selected from SW1. The number 1 and 2 on SW1 are denoted as axis X and Y, respectively. The number 3 and 4 on SW1 are reserved for future work. Fig. 3-7 is the default setting to connect the EMG signals to GND. The X-EMG and Y-EMG signal from CON4 not take effect. If the switch is disconnected as shown in Fig. 3-8, the emergency stop signals can be controlled from the X-EMG and Y-EMG signal in CON4.

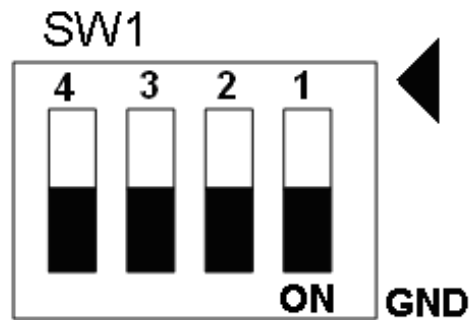

Fig. 3-7 SW1 setting for normally GND (Default setting)

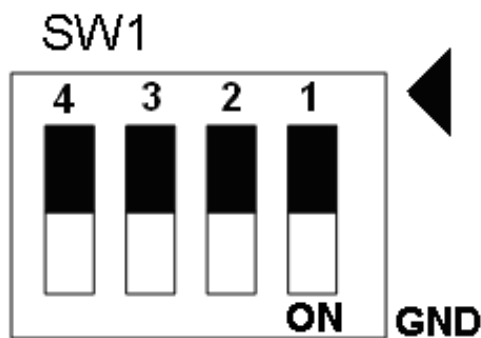

Fig. 3-8 SW1 setting for user controlled signals.

■ JP1/2 & JP3/4

Jumper 1, 2 controls the XPP, XPM signals of the CON2. The couple of jumpers are indicated the type of pulse output signal for X axis. However there are the same jumper settings for Y axis (Jumper 3, 4 for Y axis). The following diagram is shown the selection condition of the jumper 1, 2.

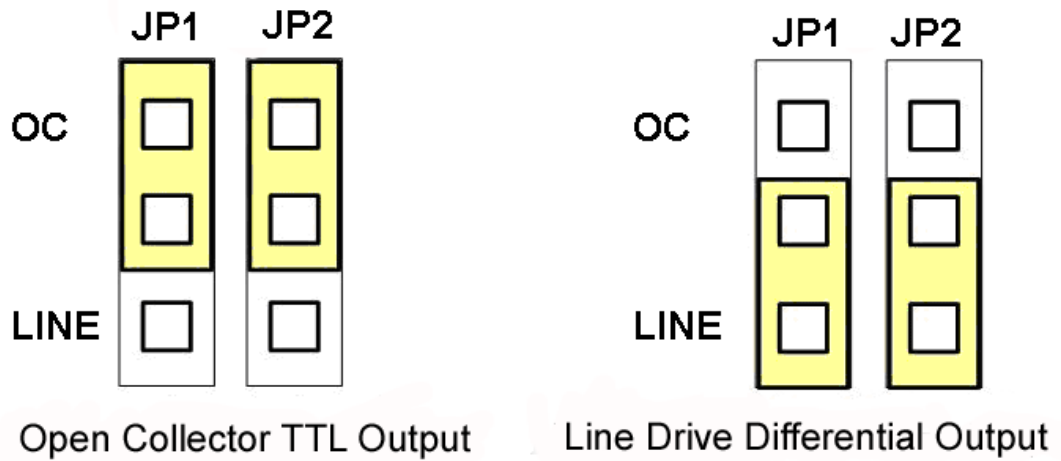

Fig. 3-9 Jumper 1, 2 setting

2.3 Input/Output Connections

The signal connections of all the I/O signals are described in this chapter. Please refer the contents of this chapter before wiring the cable between the i8092F and the motor drivers.

2.3.1 Pulse output signals

There are 2-axis pulse output signals on I8092F. For every axis, two pairs of CW and CCW signals are used to send the pulse train. The CW and CCW signals can also be programmed as PULSE and DIR signals pair. Two types of the pulse output signal, Differential-Type and Open-Collector Type, can be selected from JP2/3 and JP4/5 and are described in section 2.2.2. The following wiring diagram is for the CW and CCW signals of the 2-axis.

◆ Output to Motor Drivers in Differential Circuit

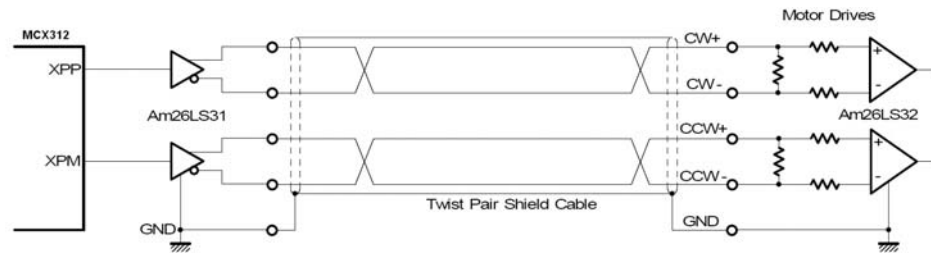

Fig. 2.8 Differential-Type pulse output circuit

◆ Open Collector TTL Output

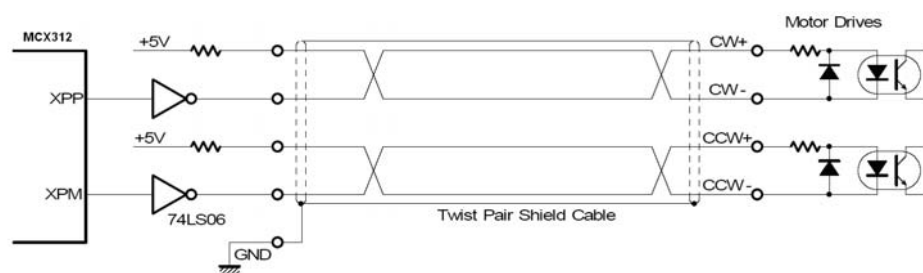

Fig. 2.9 The wiring is open collector output

■ Example: wiring of pulse signal

Two types of pulse output signal, Differential-Type and Open-Collector Type, can be selected from JP2/3 and JP4/5 for each axis. The following wiring diagram is an example to select pulse type of the output signal

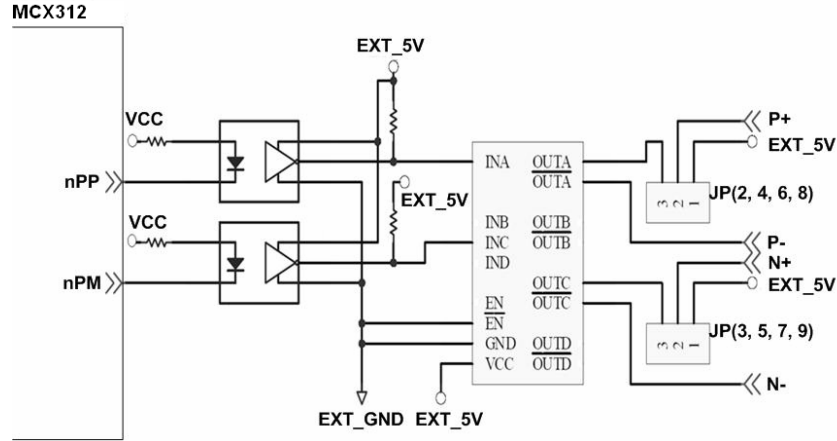
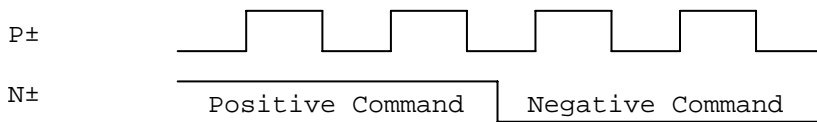

Fig. 2.10 Output pulse example

◆ Pulse/Direction Pulse Output Mode:

In Pulse/Direction pulse output mode, the PULSE signal is output only at Pulse pins (P+, P-). The driving direction is decided from the electric potential of Direction pins (N+, N-). The following diagram is example signal of Pulse/Direction pulse output mode.



◆ CW/CCW Pulse Output Mode:

In CW/CCW pulse output mode, the PULSE signal is output at both CW pins (P+, P-) and CCW pins (N+, N-). At the same time, the driving direction is determined directly. The following diagram is example signal of CW/CCW pulse output mode.

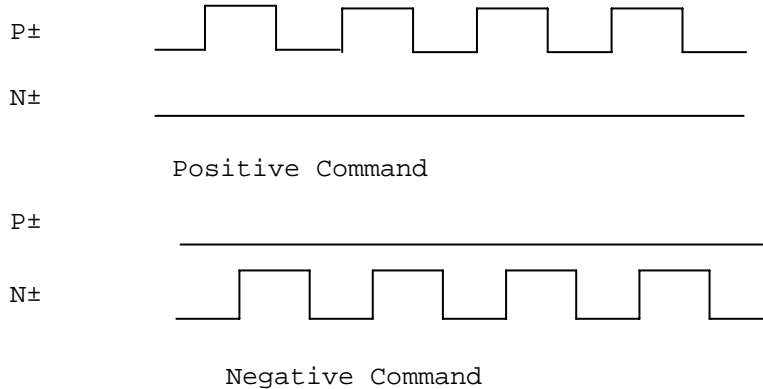

2.3.2 Connection for Limit switch Signal

Limit Switch Signal can prevent the over traveling appearance of the motion system. User can set the hardware limit switch signal to be normal open or normal close by the software instruction in I8092F software manual. The following figure indicates that the photo couplers are used to keep out the sensor noise of the Limit Switch.

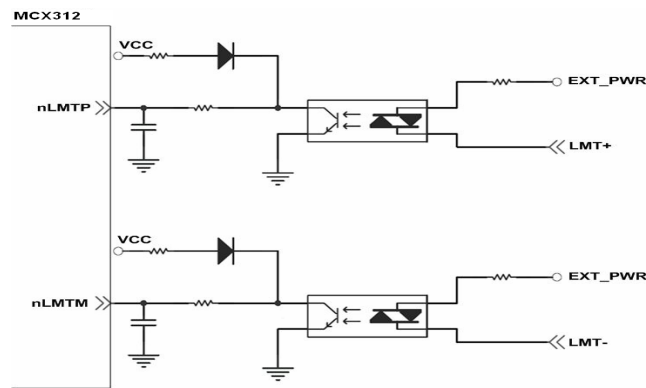

Fig. 2.11 Limit switch signal circuit

2.3.3 General Purpose Input Signals(nINPOS,nALARM)

INPOS is a digital input signal to indicate the In-Position signal of the driver. User can enable or disable the signal from the software instruction in I8092F software manual.

ALARM is a digital input signal to indicate the servo alarm signal of the driver. The output pulse will be stop if I-8092F receives the ALARM signal. User can enable or disable the signal from the software instruction in I8092F software manual.

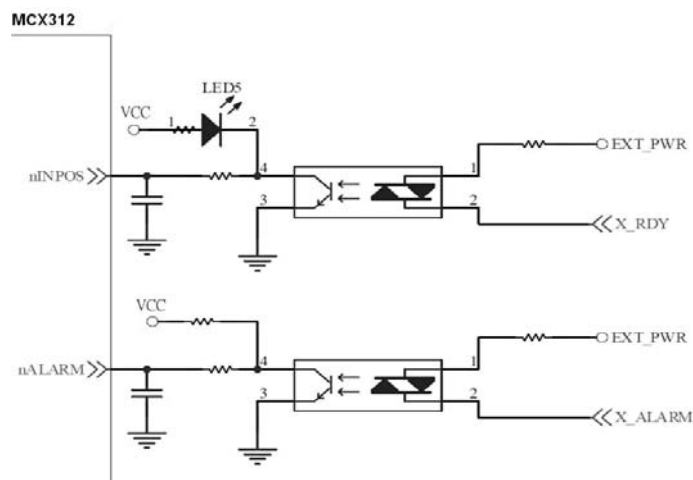

Fig. 2.12 General Digital Input circuit

2.3.4 Encoder Signals

The following diagram is for Differential-Type encoder signals. Connect the Phase A signal to A+ and A- pins and connect Phase B signal to B+ and B- pins. After the high speed photo coupler isolation, the isolated encoder signals are connected to motion IC.

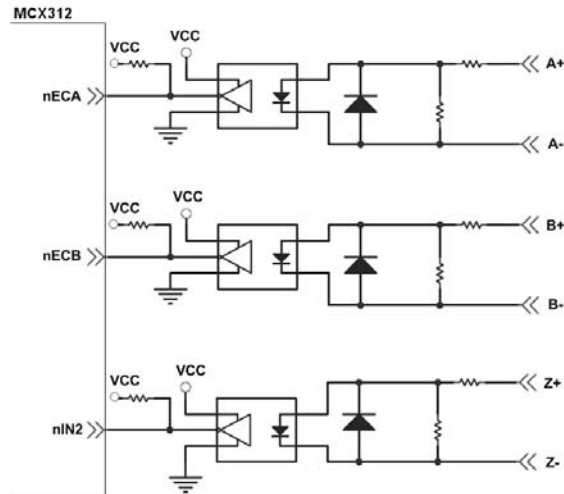

Fig. 2.13 Encoder signal connection

2.3.5 Emergency Stop Signal

The following diagram is for Emergency STOP signal. If the emergency signal is occurred, the output pulse for all axes will be STOP and the error flag will be set as 1. After the photo coupler isolation, the isolated emergency signal is connected to motion IC.

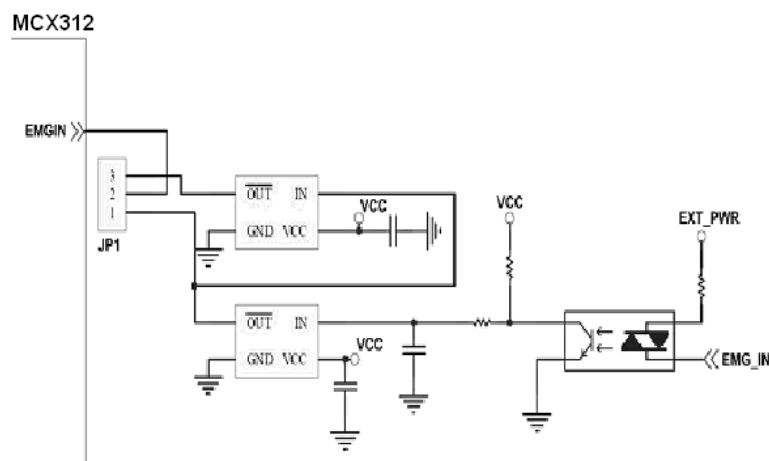

Fig. 2.14 Emergency Stop Signal connection

2.3.6 Manual Pulse Generator Input Signal (EXP+,EXP-)

The signals, EXP+ and EXP-, are used for manual pulsar signals. The following diagram is an example connection for the external inputs. User can set the signals as fixed pulse CW/CCW mode, continuous pulse CW/CCW mode, or A/B phase manual pulsar mode by using the setting in section 3.5.

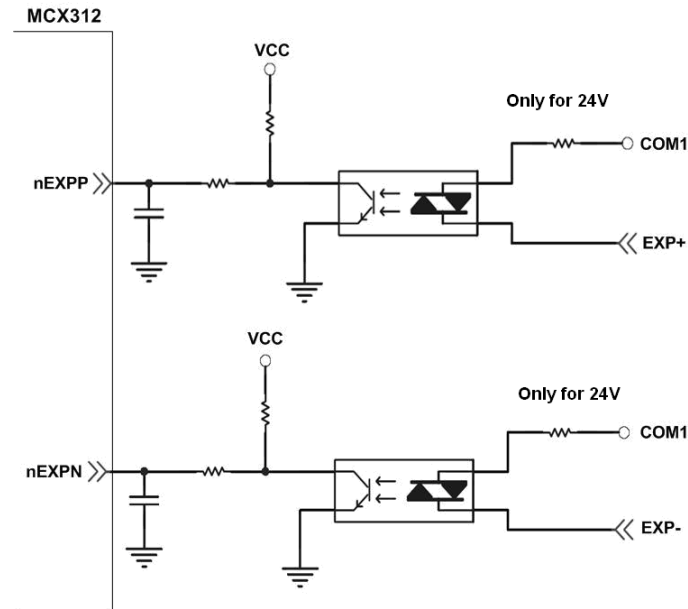

Fig. 2.15 EXP+/- connection diagram

2.3.7 General Purpose Output signals(Servo On/Off)

The following diagram is a digital output signal for driver Servo On/Off signal. The output signal enable or disable the driver.

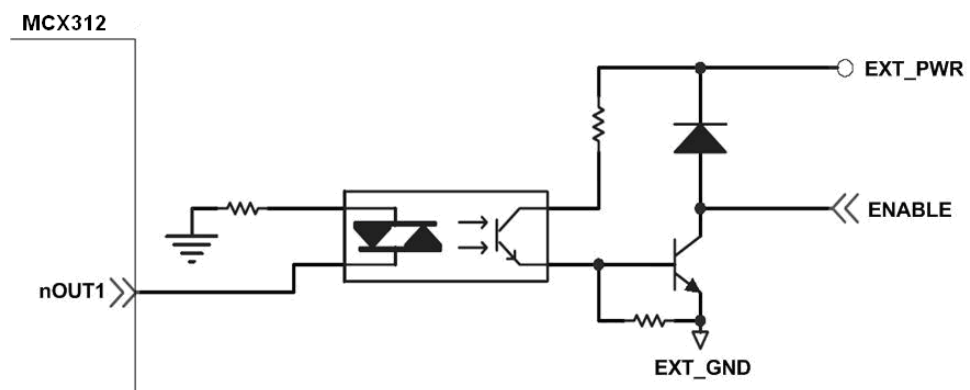

Fig. 2.16 Servo On/Off signal connection diagram

2.4 Connection Example for Motor Driver

The following diagram is the connection example between MITSUBISHI MR-J2S AC servo driver and the extension board DN-8237.

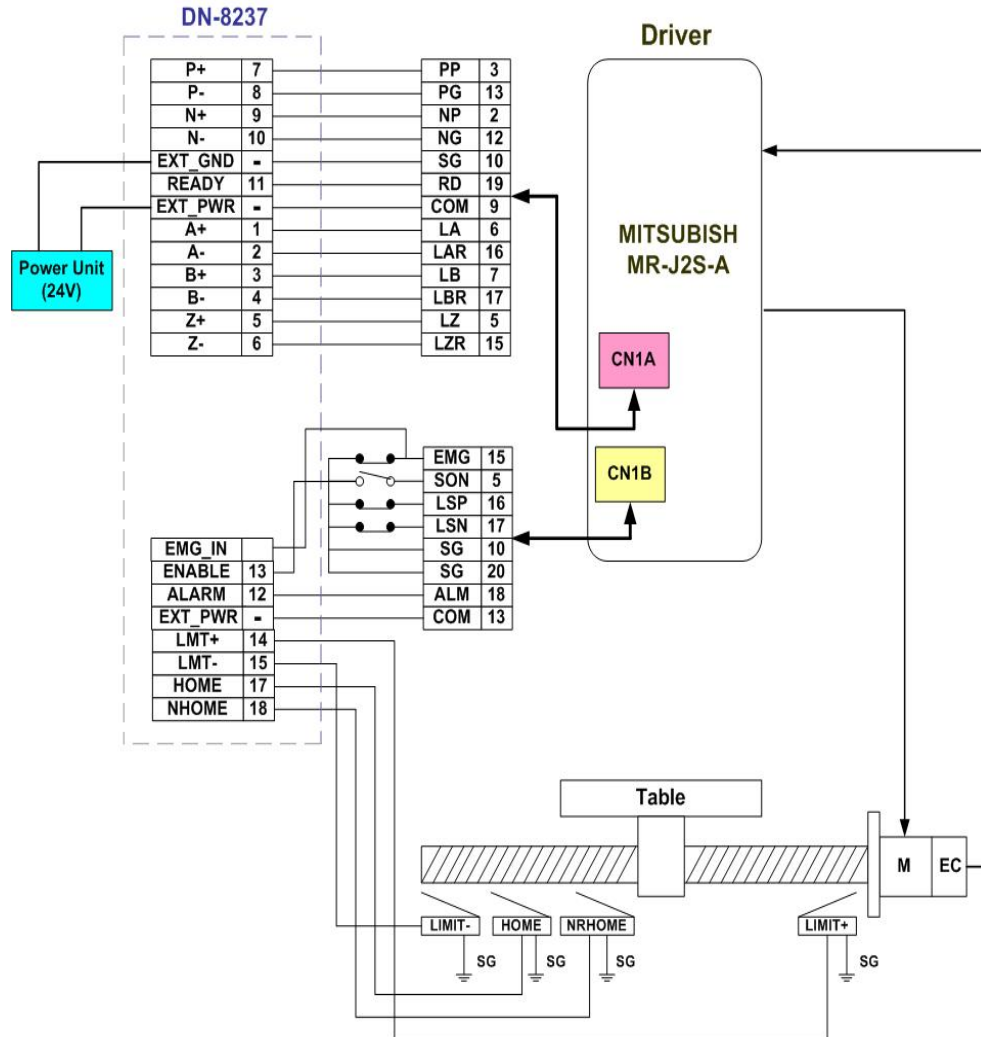
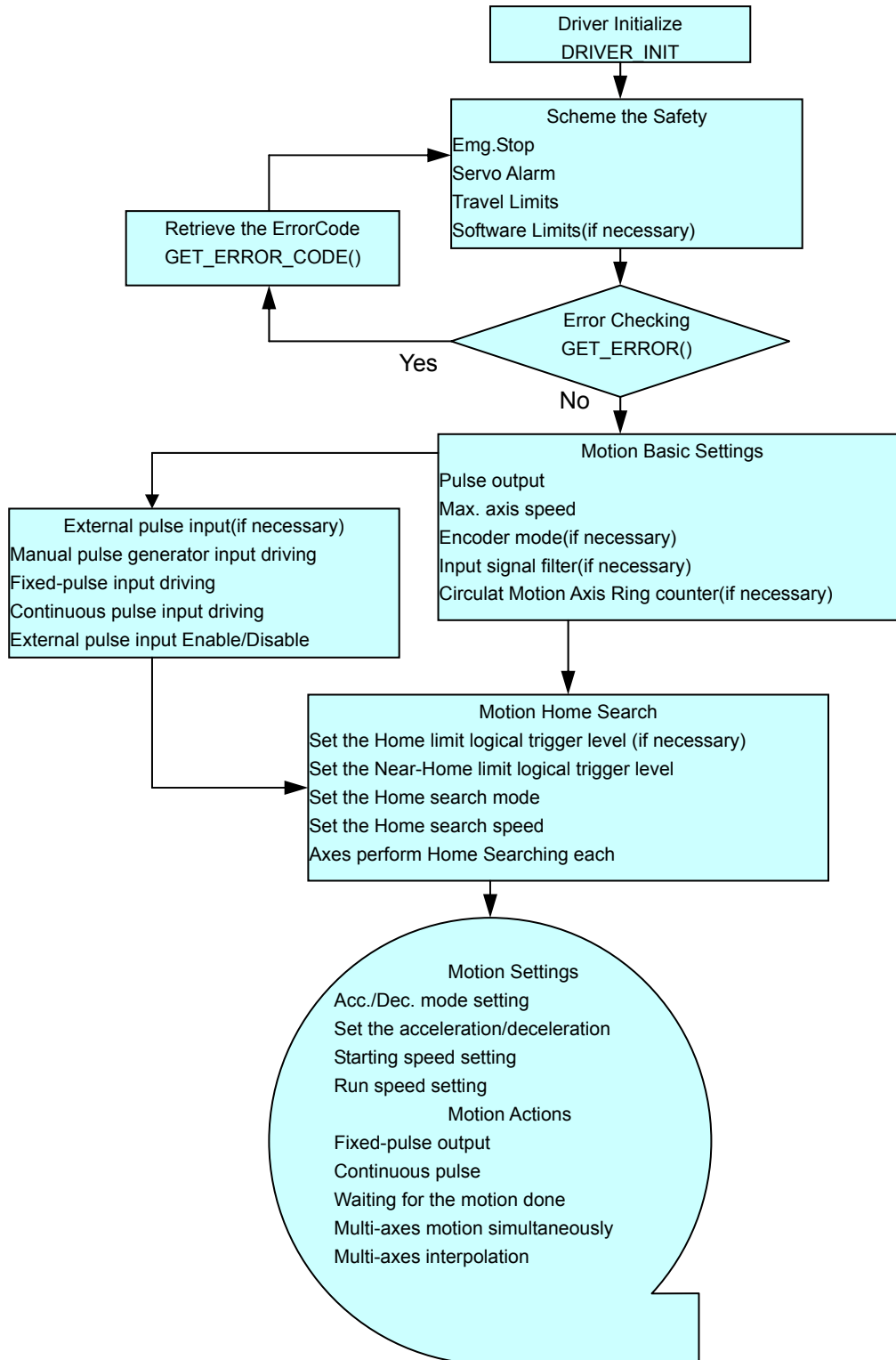

Fig. 2.17 The connection between MR-J2S AC servo driver and DN-8237 extension board.

3 Software Development Overview

3.1 Software development Overview

Please refer to the demo_start sample



3.1.1 Register Module

User must register for each I8092F module before sending command otherwise user will get error. Please refer to *i8092MF_REGISTRATION()* function, the section 2.2 of I8092F user manual.

3.2 Safety IO Setting

There are many reasons to stop motion during driving. Some reasons are described in this subsection.

3.2.1 Emergency Stop Signal Input

Emergency Stop is especially for the purpose to stop all of the Motion operations immediately when danger occurs in order to avoid critical accident.

If you don't need to use the Emg. stop push button, configure the JP1 as pin2-3 short which describes in the section 2.2.2 .If you need the EMG signal input , configure the JP1 as pin1-2 short, and the EMG_IN signal connect to the N.C. type EMG push button switch and install it at the suitable location.

3.2.2 Configure the Servo ALARM Signals

When the ALARM signals are occurred from servomotor drivers, users can be notified by these signals and determine what to do. The operating mode (Enable or Disable) and the proper trigger level of these signals can be set by user. Please refer to *i8092MF_SET_ALARM()* function, the section 2.13 of I8092F user manual.

3.2.3 Configure the Limit Switch Signals(\pm EL)

To insure the machine in safety, hardware limit switches are placed at the both ends of machine traveling range. If the machine touch the hardware limit switch sensors, I-8092F will stop immediately. The operating mode (Enable or Disable) and the proper trigger level of these signals can be set by user. Please refer to *i8092MF_SET_HLMT ()* function, the section 2.6 of I8092F user manual.

3.2.4 Configure the Software Limite(\pm SEL)

To insure the machine in safety, hardware limit switches are placed at the both ends of machine traveling range. In addition, user can set the software limits to avoid the happening of the over range before the hardware limit takes effect. If the machine reach the software limits condition, I-8092F will stop immediately. The operating mode (Enable or Disable) and the proper trigger condition of these signals can be set by user. Please refer to *i8092MF_SET_SLMT()* and *i8092MF_CLEAR_SLMT()* function, the section 2.10 of I8092F user manual.

3.3 Error Checking

Check whether there is any error. If there are something wrongs, please use the *GET_ERROR_CODE()* function to get the error-code, then check the reason and remove it. Please refer to *GET_ERROR_CODE()* function, the section 3.6 of I8092F manual.

User also can use *i8092MF_GET_DI()* function to check the all of DI status. Please refer to *i8092MF_GET_DI()* function, the section 3.5 of I8092F user manual.

3.4 Basic Configuration of Motion

The basic Motion configuration is mainly aimed for general necessary setting, as below:

1 Pulse output mode setting: Pulse/Dir \cdot CW/CCW...

i8092MF_SET_PULSE_MODE() (Please refer to the section 2.4 of I8092F user manual)

2 Max. speed limitation setting for each axis

i8092MF_SET_MAX_V()(Please refer to the section 2.5 of I8092F user manual)

3 Encoder input setting

i8092MF_SET_ENCODER()(Please refer to the section 2.11 of I8092F user manual)

4 DI noise filter setting(If necessary)

i8092MF_SET_FILTER()(Please refer to the section 2.15 of I8092F user manual)

5 Circular motion declaration(Ring counter)(If necessary)

i8092MF_VRING_ENABLE()(Please refer to the section 2.16 of I8092F user manual)

3.5 Manual Pulse Generator Testing

User can use the manual pulse generator function directly to drive motion forward or backward. For further wiring and parameter tuning, user have to check the correction of the DI signals and the moving direction.

The manual pulse generator can be achieved from three driving methods described below:

1. A/B phase Manual Pulse Generator:

Use the A/B phase Manual Pulse Generator for forward/backward moving.

i8092MF_EXD_MP()(Please refer to the section 2.18.1 of I8092F user manual)



2. Fixed-pulse driving Manual Pulse Generator:

User have to preset fixed driving pulses. After setting, user can push the forward or backward button to drive fixed pulses for each direction.

i8092MF_EXD_FP()(Please refer to the section 2.18.2 of I8092F usere manual)

3. Continuous- pulse driving Manual Pulse Generator:

User can preset output-pulse frequency. After setting, user can push the forward or backward button to drive fixed velocity for each direction. If user release the button, the motion will be stop immediately.

i8092MF_EXD_CP ()(Please refer to section 2.18.3 of I8092F user manual).

4 Disable external pulse input:

Disable external pulse input by this command after operating anyone of three functions above.

i8092MF_EXD_DISABLE() (Please refer to section 2.18.4 of I8092F user manual)

3.6 Home Search

I8092F provides the home function of automatic search. Operate that automatically after setting properly. The main steps is as bellow:

- Near-home sensor searching under high-speed motion.
- Near-home sensor searching under high-speed motion.
- Servomotor Z-phase searching under low-speed motion.
- Offset movement to the origin of the working area under high-speed motion.

User can select which steps are ignored when setting for the actual operation. It performs automatically that economize the CPU resource and program code reducing. Although there are four home search steps, but user can create more than 10 types of different home search mode by vary with the software functions. It is attributed to the configurable home search direction and perform it or not of each step.

3.6.1 Home Search Configuration

1. Logic level setting for Near home sensor and Home sensor (If necessary)

i8092MF_SET_NHOME() (Please refer to section 2.8 of I8092F user manual)

- 2 Home sensor logic level setting

i8092MF_SET_HOME_EDGE() (Please refer to section 2.9 of I8092F user manual)

- 3 Auto-Home

i8092MF_AUTO_HOME() (Please refer to section 5.2 of I8092F user manual)

- 4 Step by step Home function (Only Software)

BYTE i8092MF_SEARCH_NHOME()

BYTE i8092MF_SEARCH_HOME()

BYTE i8092MF_SEARCH_ZPHASE()

Please refer to section 5.3 of I8092F user manual.

3.7 Basic Motion

3.7.1 Speed Profile of the Motion Control

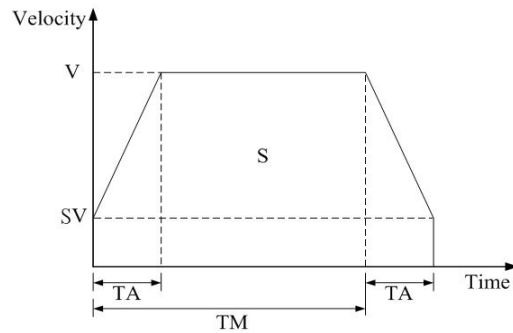

1 Symmetrical T-profile of motion velocity

(If SV is larger than V or equal to V, perform constant velocity driving)

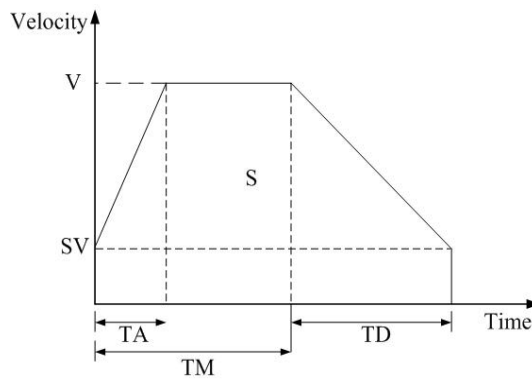

2 Asymmetrical T-profile of motion velocity

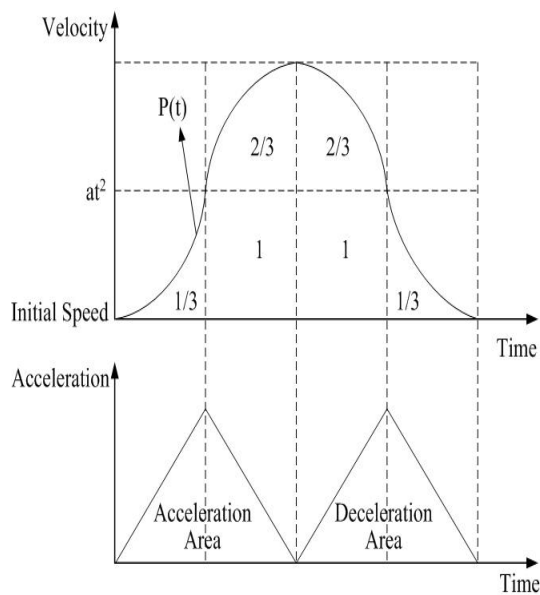

3 Symmetrical S-curve of motion velocity

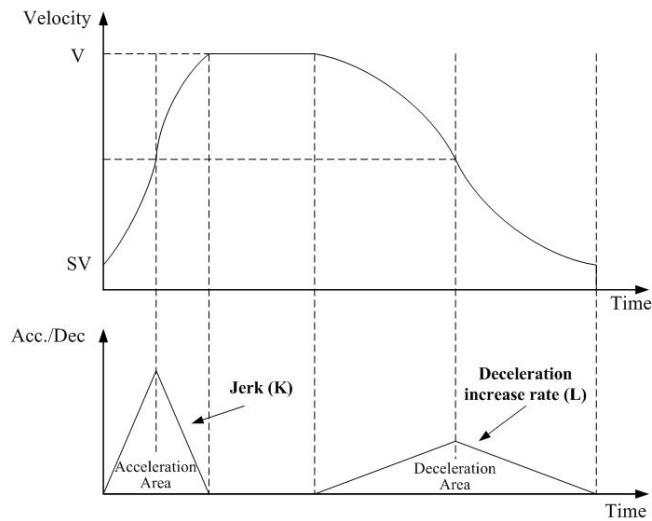

4 Asymmetrical S-curve of motion velocity

3.7.2 Basic Setting of Single Axis

1 Setting the mode of Acceleration/deceleration: There are four speed modes

0 → Symmetrical T-Profile (SV、V、A、AO)

1 → Symmetrical S-curve (SV、V、K、AO)

2 → Asymmetrical T-profile (SV、V、A、D、AO)

3 → Asymmetrical S-curve (SV、V、K、L、AO)

i8092MF_NORMAL_SPEED()(Please refer to section 6.1.1 of I8092F user manual)

2 Setting the start velocity: Set lowest speed

i8092MF_SET_SV()(Please refer to section 6.1.2 of I8092F user manual)

3 Setting the Velocity: Set the desired speed

i8092MF_SET_V()(Please refer to section 6.1.3 of I8092F user manual)

4 Setting the Acceleration/Deceleration speed: Set the Acceleration/Deceleration speed.

i8092MF_SET_A()(Please refer to section 6.1.4 of I8092F user manual)

i8092MF_SET_D()(Please refer to section 6.1.5 of I8092F user manual)

3.7.3 Basic Motion of Single Axis

1 Fixed-pulse driving output: Perform fixed-quantity of single axis pulse output.

i8092MF_FIXED_MOVE()(Please refer to section 6.1.9 of I8092F user manual)

2 Continuous-pulse driving output: Perform continuous pulse output of single axis.

i8092MF_CONTINUE_MOVE ()(Please refer to section 6.1.10 of I8092F user manual)

3 Waiting for motion done: Waiting for the axis driving accomplished.

i8092MF_STOP_WAIT()(Please refer to section 6.5.3 of I8092F user manual)

3.7.4 Basic Setting of Multi-Axes Interpolation

1 Setting axes of interpolation: Don't need to select axes to do the interpolation.

2 Setting the mode of Acceleration/Deceleration of vector: There are seven modes as below:

0 → 2-axis(Linear & ARC & Circular) Fixed-vector velocity (VV)

1 → 2-axis linear symmetrical T-profile (VSV、VV、VA、VAO)

2 → 2-axis linear symmetrical S-curve (VSV、VV、VK、VAO)

3 → 2-axis linear asymmetrical T-profile (VSV、VV、VA、VD、VAO)

4 → N/A

5 → 2-axis (ARC & Circular) symmetrical T-profile (VSV、VV、VA、VAO)

6 → 2-axis (ARC & Circular) asymmetrical T-profile (VSV、VV、VA、VD、VAO)

i8092MF_VECTOR_SPEED()(Please refer to section 6.2.2 of I8092F user manual)

2 Setting the start vector velocity: Set the lowest vector speed.

i8092MF_SET_VSV()(Please refer to section 6.2.3 of I8092F user manual)

3 Setting the vector velocity: Set the desired vector speed

i8092MF_SET_VV()(Please refer to section 6.2.4 of I8092F user manual)

4 Setting the velocity of Acceleration/Deceleration of vector: Set the speed of

Acceleration/Deceleration of vector.

i8092MF_SET_VA()(Please refer to section 6.2.5 of I8092F user manual)

i8092MF_SET_VD()(Please refer to section 6.2.6 of I8092F user manual)

3.7.5 Basic Motion of Multi-Axes Interpolation

1 2-axis linear interpolation: Perform 2-axis linear interpolation.

i8092MF_LINE_2D()(Please refer to section 6.2.10 of I8092F user manual)

2 2-axis ARC interpolation: Perform 2-axis ARC interpolation.

i8092MF_ARC_CW ()(Please refer to section 6.2.12 of I8092F user manual)

i8092MF_ARC_CCW ()(Please refer to section 6.2.12 of I8092F user manual)

3 2-axisCircular interpolation: Perform 2-axis Circular interpolation.

i8092MF_CIRCLE_CW ()(Please refer to section 6.2.13 of I8092F user manual)

i8092MF_CIRCLE_CCW ()(Please refer to section 6.2.13 of I8092F user manual)

3.8 Advance Motion

1 2-axis continuous interpolation of rectangle: Perform 2-axis continuous interpolation of rectangle.

i8092MF_RECTANGLE()(Please refer to section 6.4.1 of I8092F user manual)

2 2-axis continuous interpolation of line:

Initial setting continuous interpolation of 2-axis line(Symmetrical T-profile).

i8092MF_LINE_2D_INITIAL()(Please refer to section 6.4.2 of I8092F user manual)

manual)

Perform 2-axis continuous interpolation of line.

i8092MF_LINE_2D_CONTINUE()(Please refer to section 6.4.2 of I8092F user manual)

3 Others continuous interpolation: Muti-point continuous interpolation, 3-axes Helix interpolation, 2-axis Ratio motion (Please refer to section 6.4.4~6.4.7 of I8092F user manual)

4 GETTING STARTED OF SOFTWARE

4.1 WinCon eVC++ Guideline

4.1.1 Confirm the Relative Files

Please confirm you have the following relevance files:

1. I8092.lib
2. I8092.dll
3. I8092.h

If you don't have, please look for CD or download the latest edition from ICPDAS's website <http://www.icpdas.com/download/download-list.htm> .

4.1.2 Create a new eVC++ Application Project

Please execute the Microsoft eVC++ 4.0. Then click“File” -> “New” to create a new application project. In the “Projects“ property page, choose “WCE MFC AppWizard (exe)” option and specifythe project name "Demo_First", then key in the disk path in the “Location” field, then select the “Win 32[WCE ARMV4]“ in CPU list. If necessary, please also select others options together. And then click ” OK” .

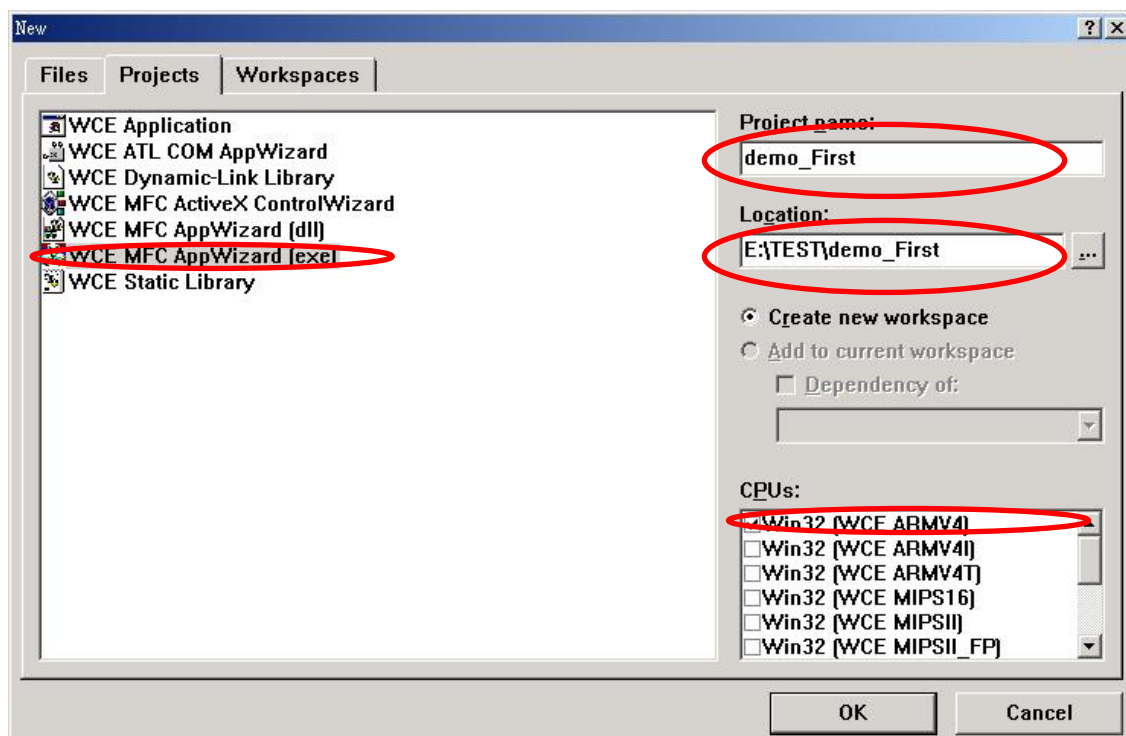

Choose “ Dialog based “ and click “NEXT”

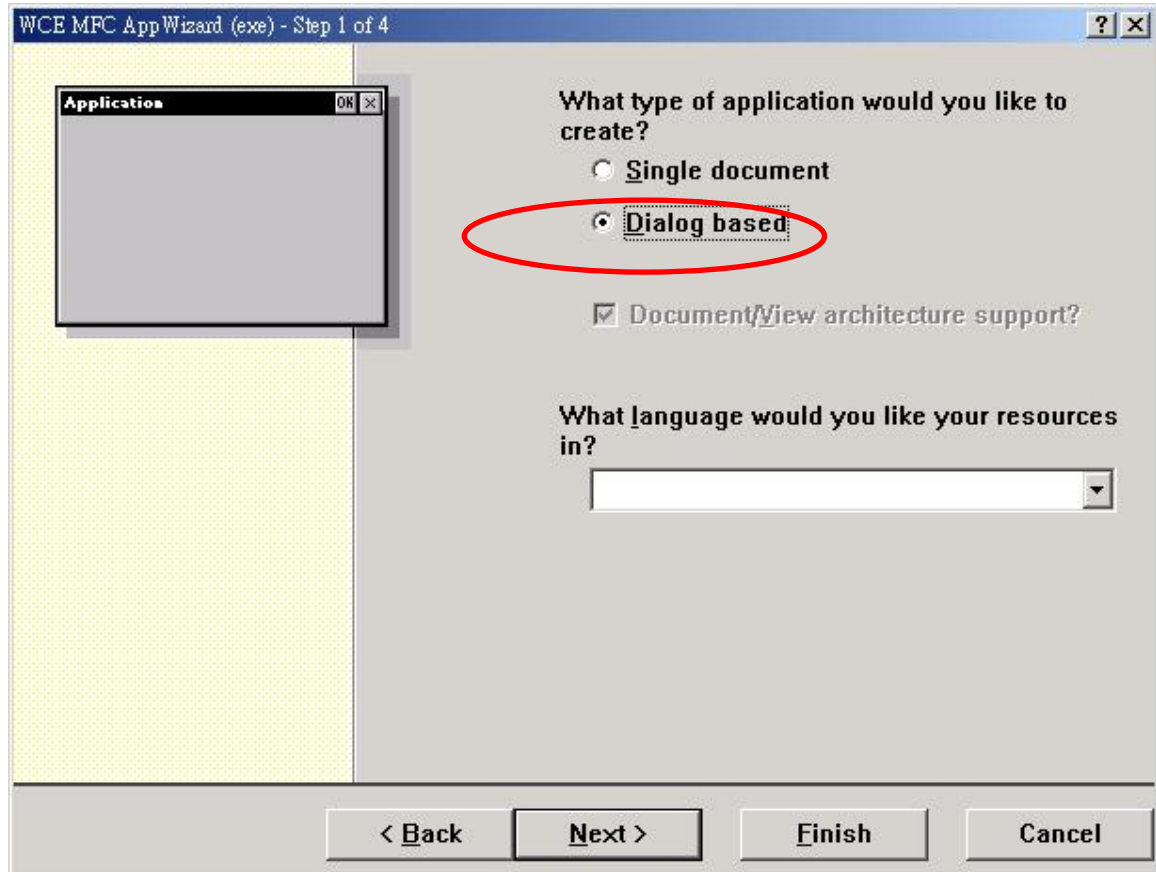

Click "Finish" and finish the new project establishment.

4.1.3 Add the I8094.h into eVC++ Application Project

Add the i8092.h into the WorkSpace of application project, as below:

Click the right key of mouse on Header Files, then choose “Add Files to Folder...”

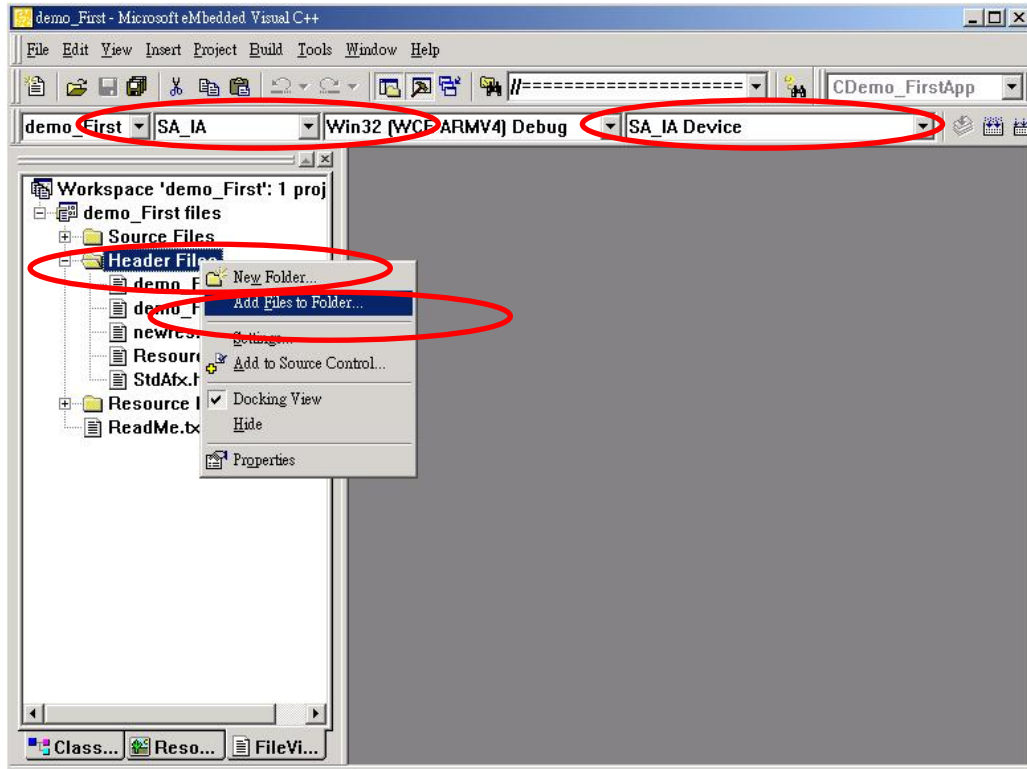

It will appear on a dialog of selecting file, find out the I8092.h and click OK.

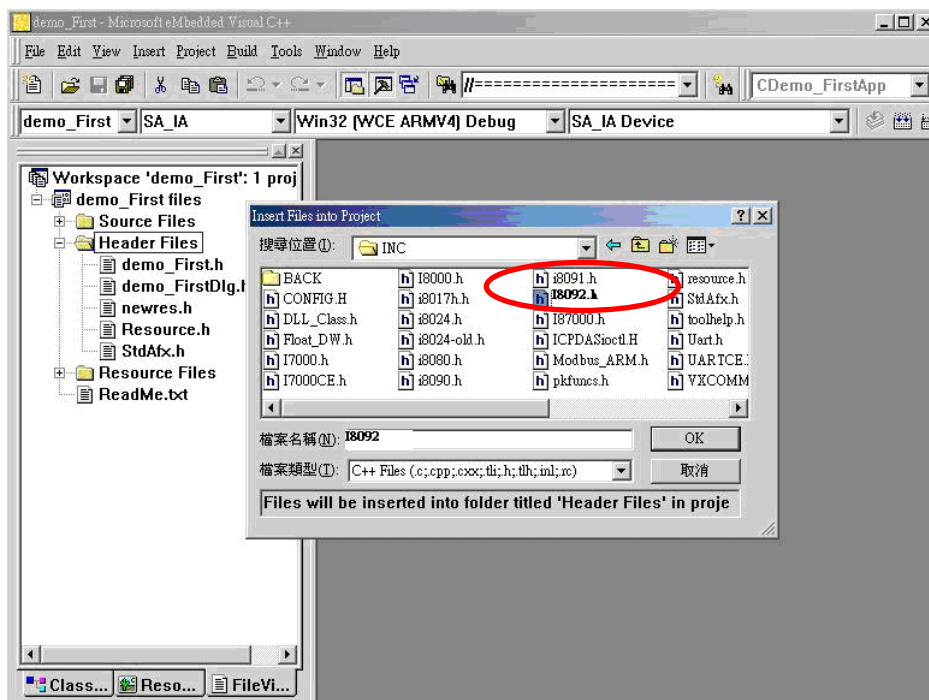

4.1.4 Add the Reference Path into eVC++ Application Project

- A. Open the “Options” dialog in “Tools” menu.
- B. Select “Directories” , then select the “SA_IA” in “Platform” item. Then select the “Win32 [WCE ARMV4]” in “CPUS” item and select the “include files” in “Show directories” item.
- C. Add in the path of including files. Double-click the rectangle in the bottom of “Directories” List-Box. Please key in the specific path that your header files located. For instance, C:\DAQPRO\Wincon\inc, as below snapshot.
- D. Then select the “Library files” in “Show directories” item.

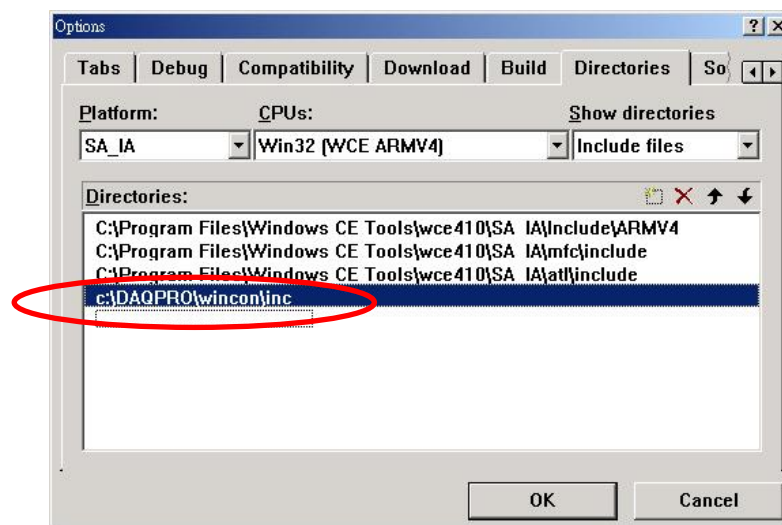

- E. Add in the path of library files. Double-click the rectangle in the bottom of “Directories” List-Box. Please key in the specific path that your header files located. For instance, C:\DAQPRO\Wincon\lib, as below snapshot.

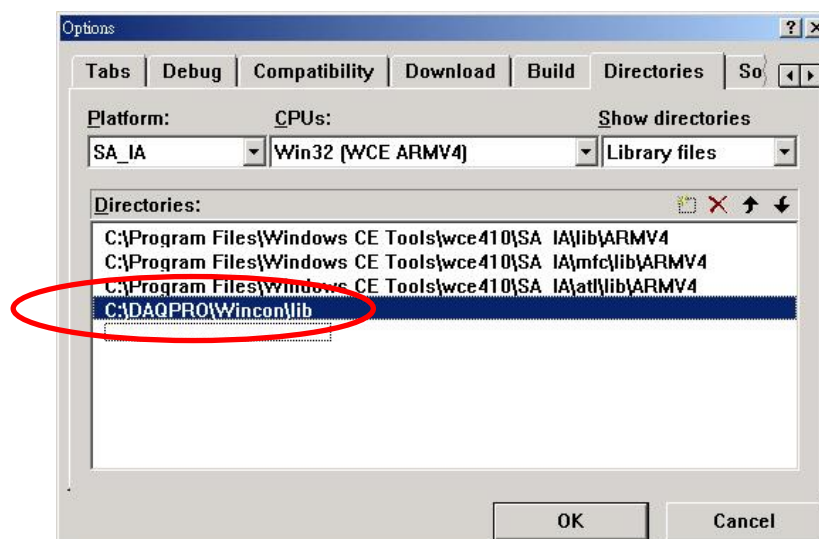

4.1.5 Start the eVC++ Sample

Add a BUTTON on Dialog, as below snapshot:

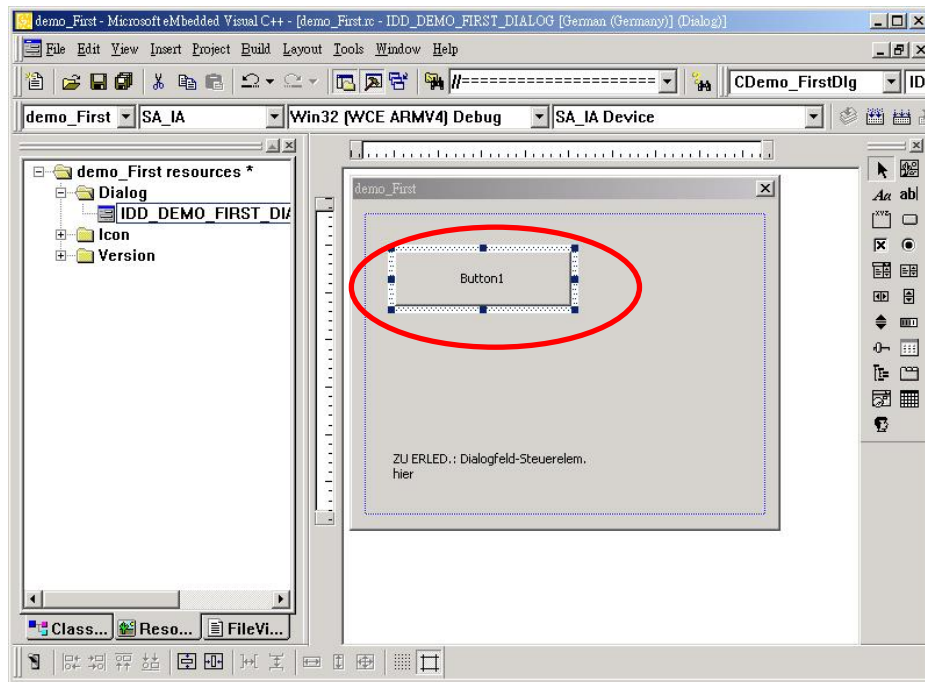

Double-click on BUTTON and generate subprogram, then add "#include "i8092.h", "WinConSDK.h", and declare CI8092MF I8092MF & bool Driver_Open & BYTE cardNo=0 in start point, as below snapshot:

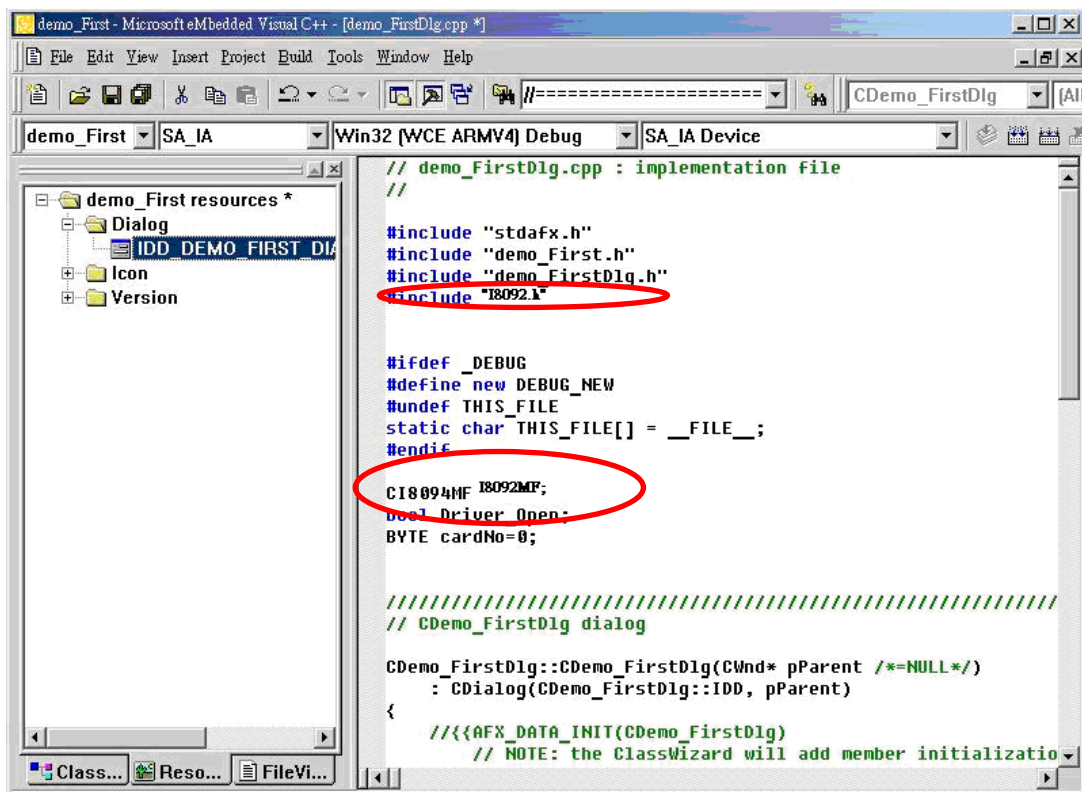

Because we have built a class “CI8092MF(For Macro function)”, it is convenient to guide in designing program. User also can use the function of manual directly. Double-click on BUTTON that will generate a subprogram, then key in “I8092MF”, then it will appear a windows guide to help user to select a relevance function.

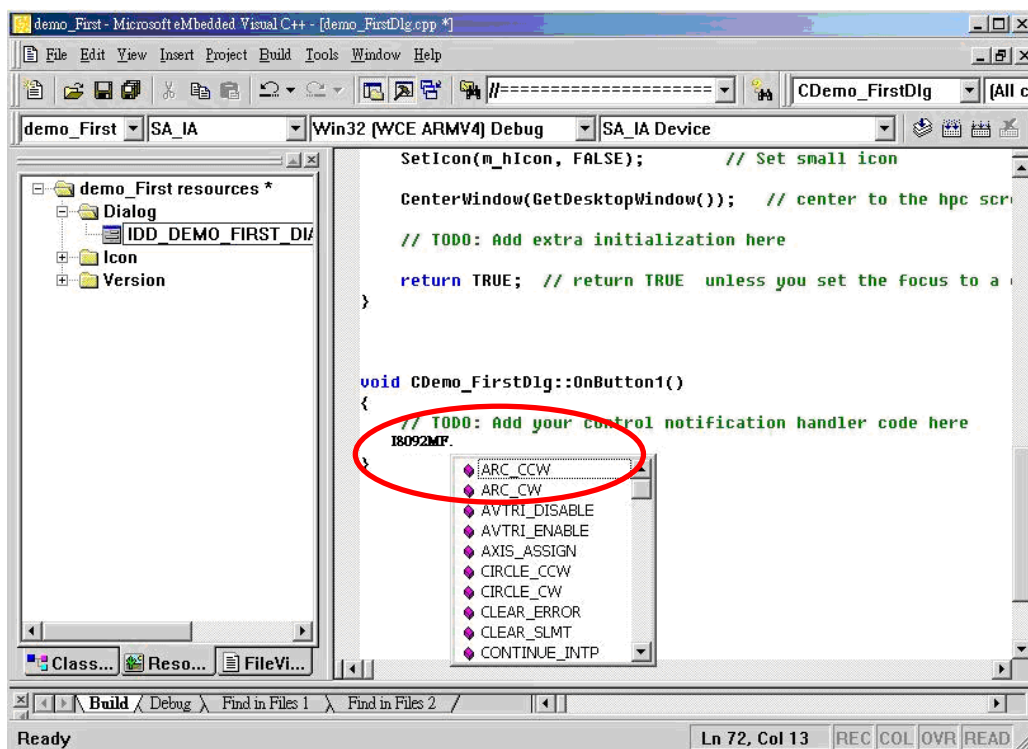

Select “i8092MF.REGISTRATION” and key in (cardNo,3), that indicate the i8092F on third slot is registered to 0th module. The detailed procedure is as below:

```

//====='Step 1 Driver init
if (!Driver_Open)
{
    I8092MF.REGISTRATION(cardNo,3);
    Driver_Open = true;
}

//====='Step 2 CONFIG IO
I8092MF.RESET_CARD (cardNo);
I8092MF.SET_PULSE_MODE (cardNo, AXIS_XYZU, 2); //set the pulse output mode
I8092MF.SET_ALARM (cardNo, AXIS_XYZU, 0, 0); //disable the SERVO ALARM Input
I8092MF.SET_ENCODER (cardNo, AXIS_XYZU, 0, 0, 0); //set the encoder input type
I8092MF.SET_MAX_V (cardNo, AXIS_XYZU, 16000); //set the max speed for XYZU
I8092MF.EXD_DISABLE (cardNo, AXIS_XYZU); //set the external input Off
I8092MF.SET_LP (cardNo, AXIS_XYZU, 0); //set the Logic position =0
I8092MF.SET_EP (cardNo, AXIS_XYZU, 0); //set the Encogger position =0
I8092MF.SET_A (cardNo, AXIS_XYZU, 1000); //set the Acc =1000

```

```

I8092MF.SERVO_ON (cardNo, AXIS_XYZU);           //set the Servo_ON to servo motors
//=====Step 3 Check ERROR
WORD KK=0;
KK= I8092MF.GET_ERROR(cardNo);
CString MSGG;
if (KK != YES)
{
    //No ERROR: Step 4 Move X axis
    BYTE axis=AXIS_X; //for AXIS_X it can be to AXIS_XYZU
    I8092MF.SET_MAX_V(cardNo, axis, 20000);
    I8092MF.NORMAL_SPEED(cardNo, axis, 0);      //set axis as Symmetrical T curve mode
    I8092MF.SET_V(cardNo, axis, 20000);        //set v=10000 PPS
    I8092MF.SET_A(cardNo, axis, 100000);       //set acc=100000 PPS/S
    I8092MF.SET_SV(cardNo, axis, 10);          //set start speed=1000 PPS
    I8092MF.SET_AO(cardNo, axis, 0);           //set offset pulse (at SV speed)= 0 PS
    I8092MF.FIXED_MOVE(cardNo, axis, 10000);   //run the fixed 10000 Pulse move.
    while (I8092MF.STOP_WAIT(cardNo, axis) == NO)
    {
        DoEvents();
        Sleep(1);
        //wait for axis to stop
    }
    long AA= I8092MF.GET_LP(cardNo,axis);      //Get X Now position
}
else
{
    //Please check the ERROR CODE
    //Get X ERROR CODE
    KK= I8092MF.GET_ERROR_CODE(cardNo, AXIS_X);
    //Get Y ERROR CODE
    KK= I8092MF.GET_ERROR_CODE(cardNo, AXIS_Y);
    //Get Z ERROR CODE
    KK= I8092MF.GET_ERROR_CODE(cardNo, AXIS_Z);
    //Get U ERROR CODE
    KK= I8092MF.GET_ERROR_CODE(cardNo, AXIS_U);
    //=====
}

```

Please refer to the example “demo_First”

After you finished that, please choose the “Project”->”Setting” menu will appear the a dialgo as below, then select the “Link” item and key in “WinConSDK.lib I8092.lib”(as below snapshot) into the Object/library modules box and the click OK.

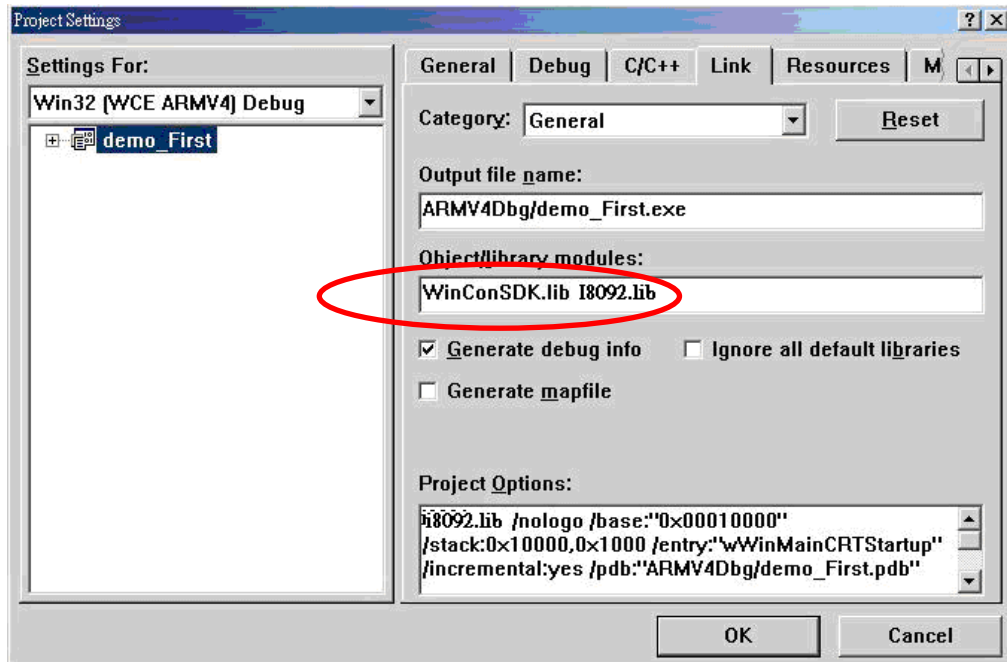

4.1.6 Build the Project

Please select the “Build” -> ”Build All” in the menu, then you will be finished this example program if there isn’t any wrong.

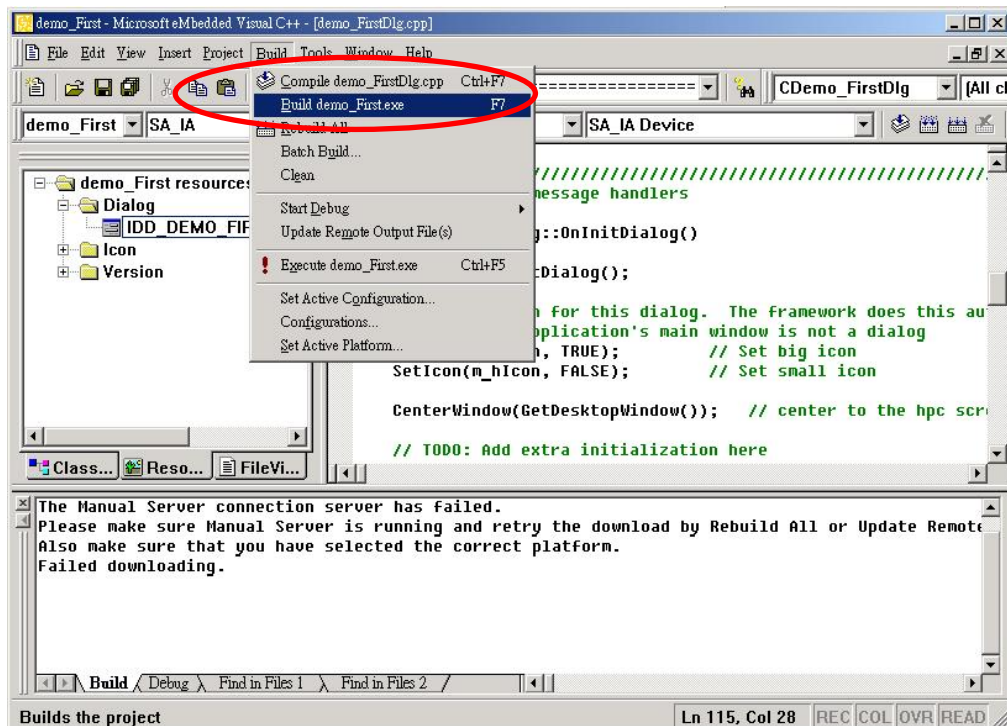

4.1.7 Download and Run

Please copy the "i8092Demo.exe" and "I8092.dll" into the same folder of WinCon (User can use the eVC++ Online Download/FTP/USB disk to do), then execute it.

4.2 Microsoft Visual Studio .NET 2003(VB.NET , C#) Guideline

Because the Microsoft Visual Studio .NET 2003 has similar environment, therefore we make an example with VB.NET.

4.2.1 Confirm the Relative Files

Please confirm you have the following relevance files:

i8092.dll

i8092_NET.dll

If you don't have, please look for CD or download the latest edition from ICPDAS's website <http://www.icpdas.com/download/download-list.htm>

4.2.2 Create a new VB.NET/C# Application Project

Please execute the Microsoft Visual Studio .NET 2003. Then create a new application project of VB and select " Smart Device Application", as below snapshot:

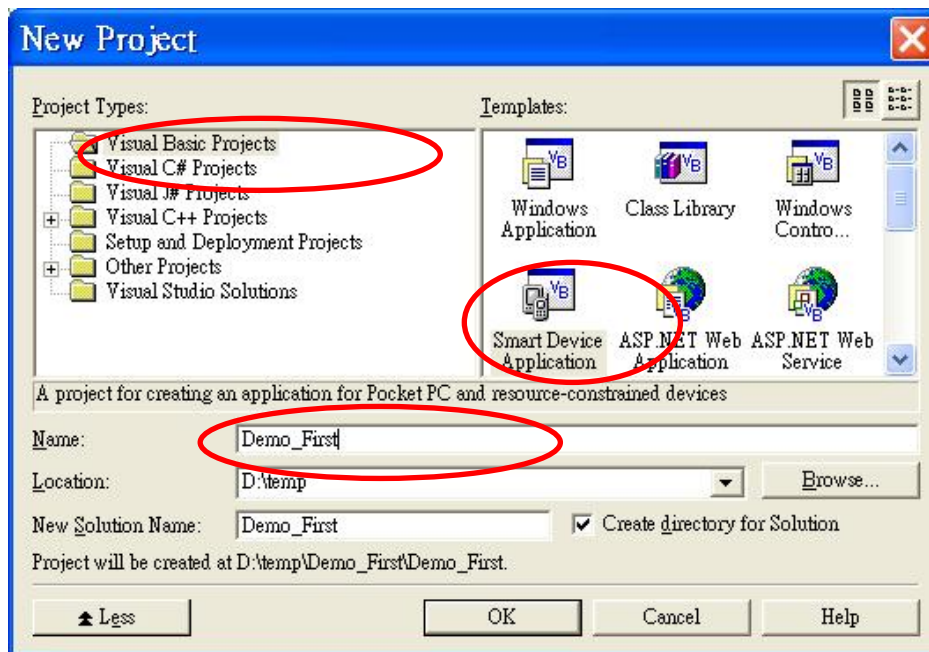

Click "OK" after finishing all of the selecting, then go to next step.

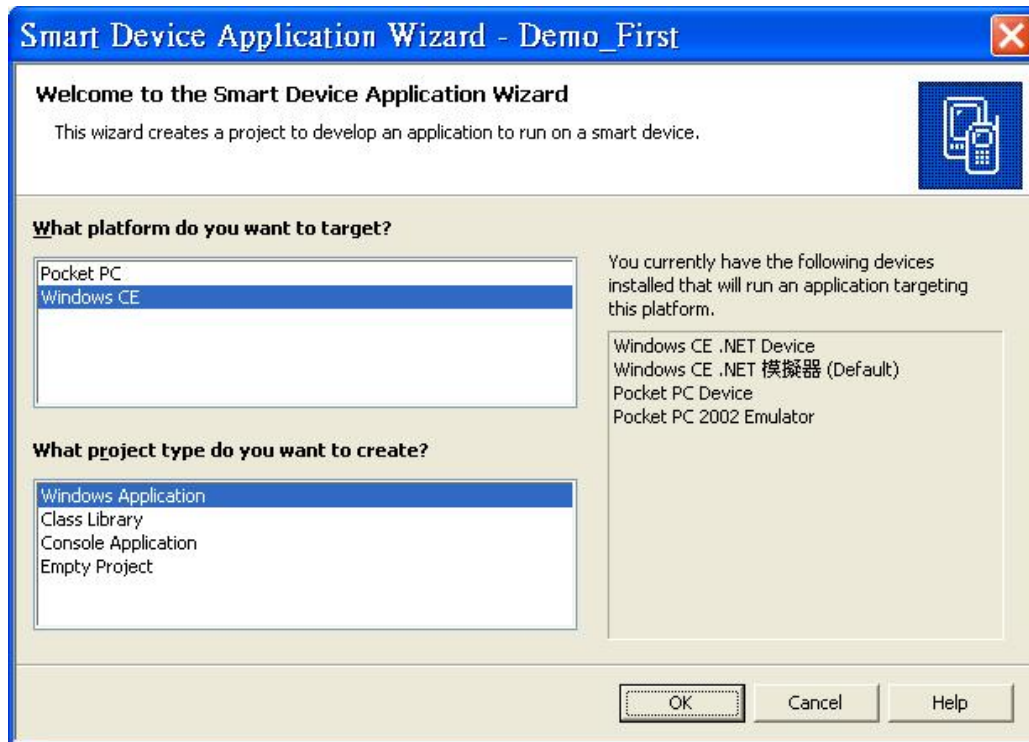

Select the “WinDows CE” and “Windows Application”, then click “OK”.

4.2.3 Add the DLL into Application Project

Click the right key of mouse on "Solution Explorer" =>add Reference

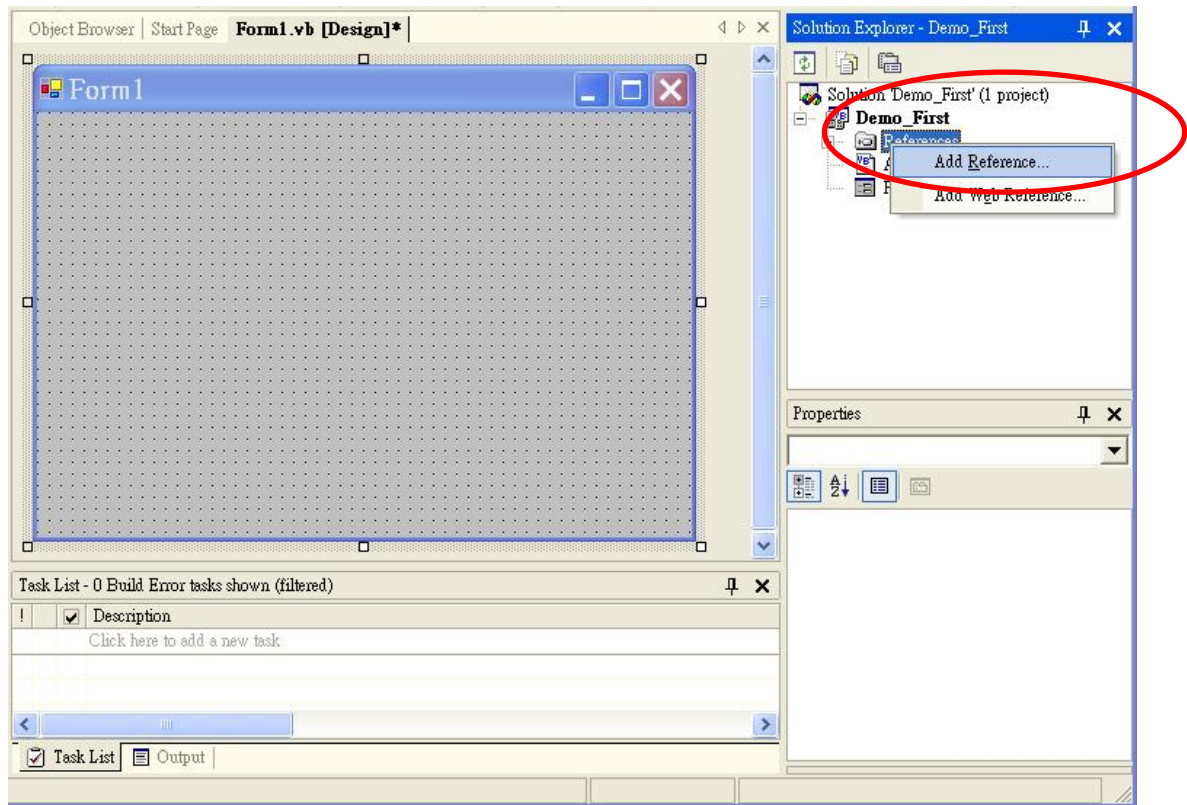

=>Select "Browse" button.

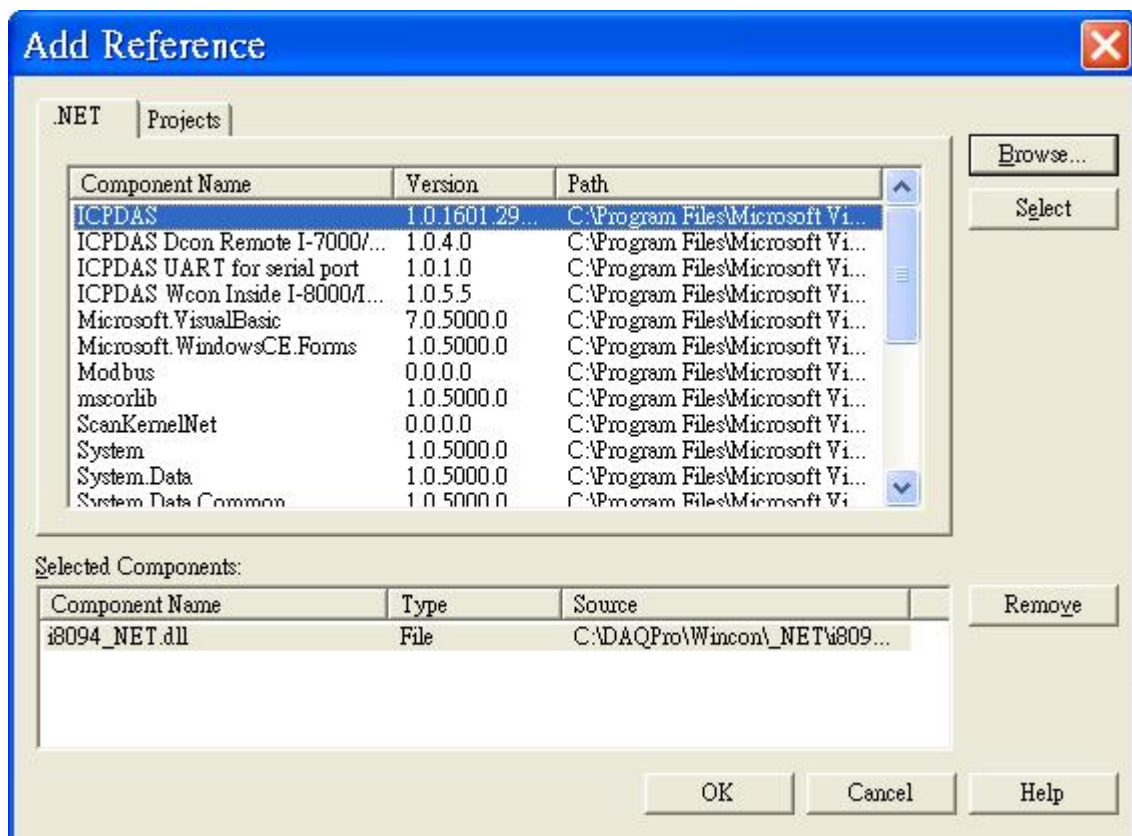

Select the i8902_NET.DLL

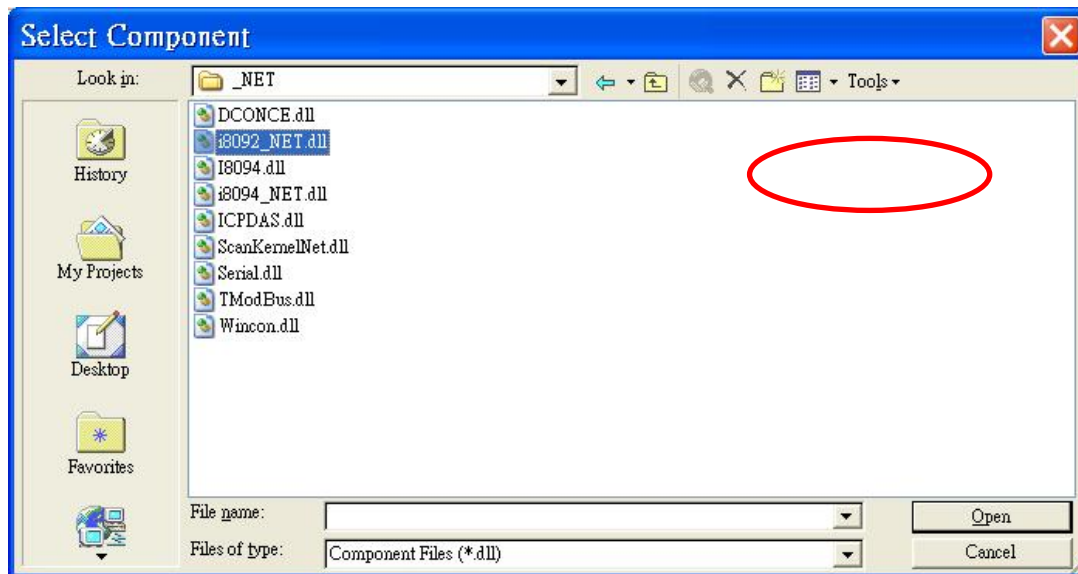

Select the "Open" button, as above snapshot:

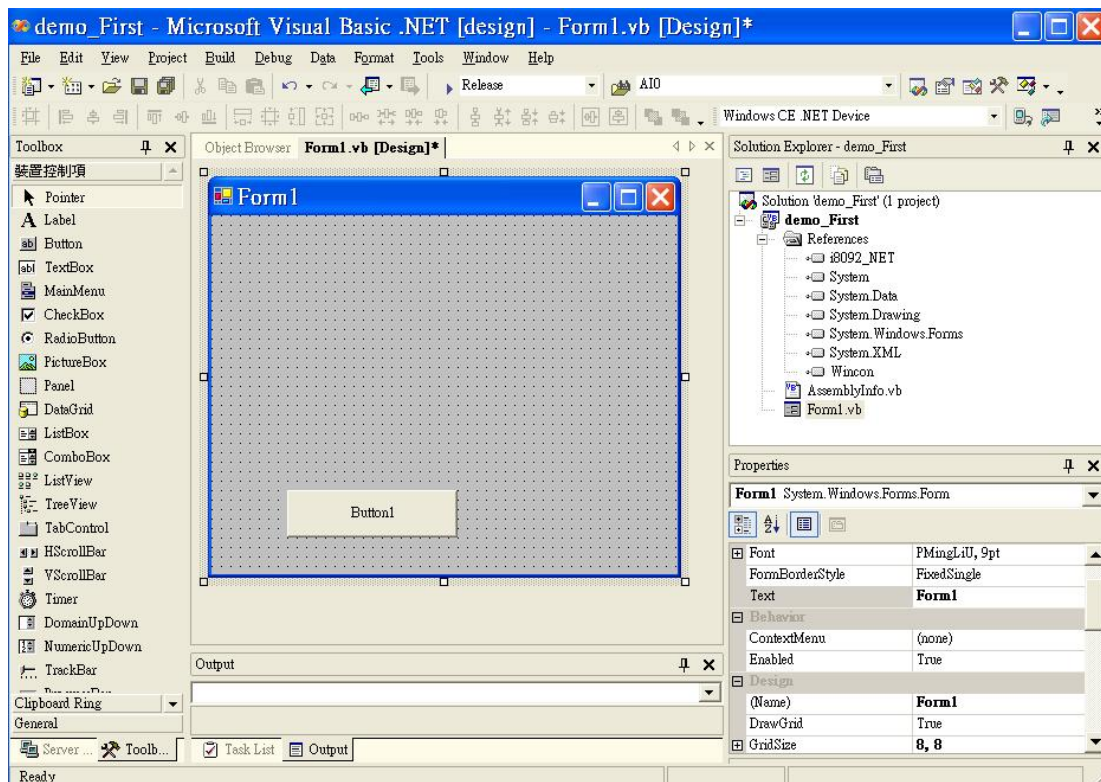

4.2.4 Start the VB.NET/C# Sample

Add a “BUTTON” on the Form1, then double-click the BUTTON, then it will appear a code of Form1.vb, then add the “imports i8092MF_NET” in top, as below snapshot:

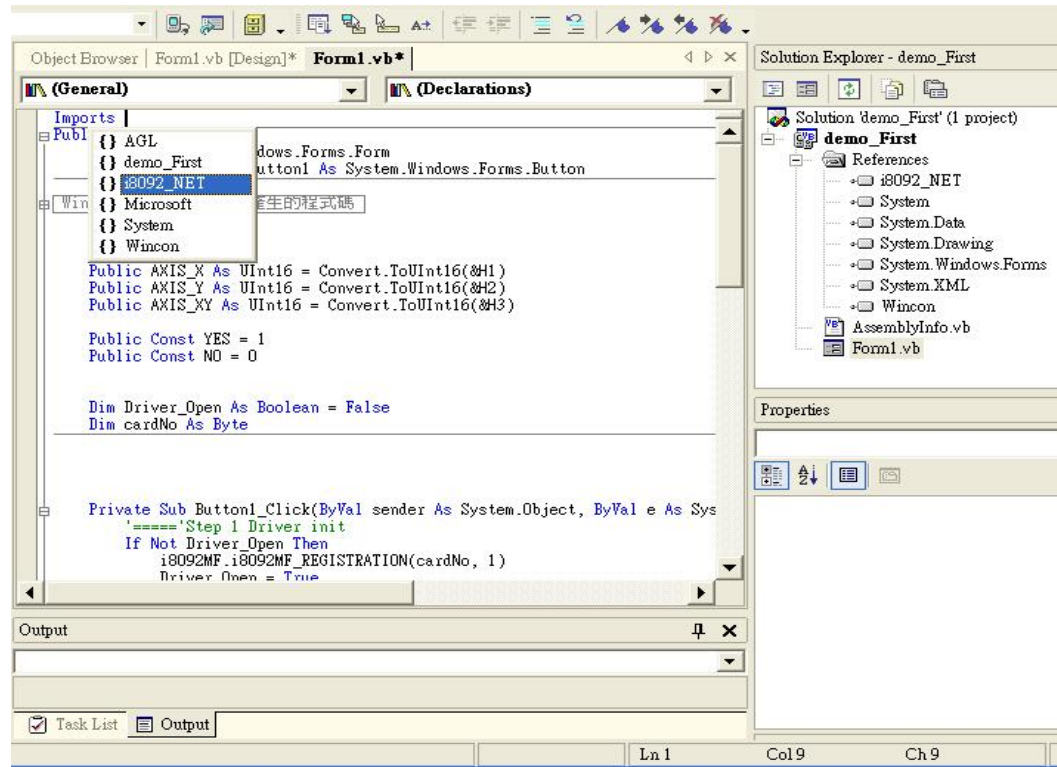

Add the “i8092MF” into the Button1_Click, then it will appear a windows guide to help user to select a relevance function.

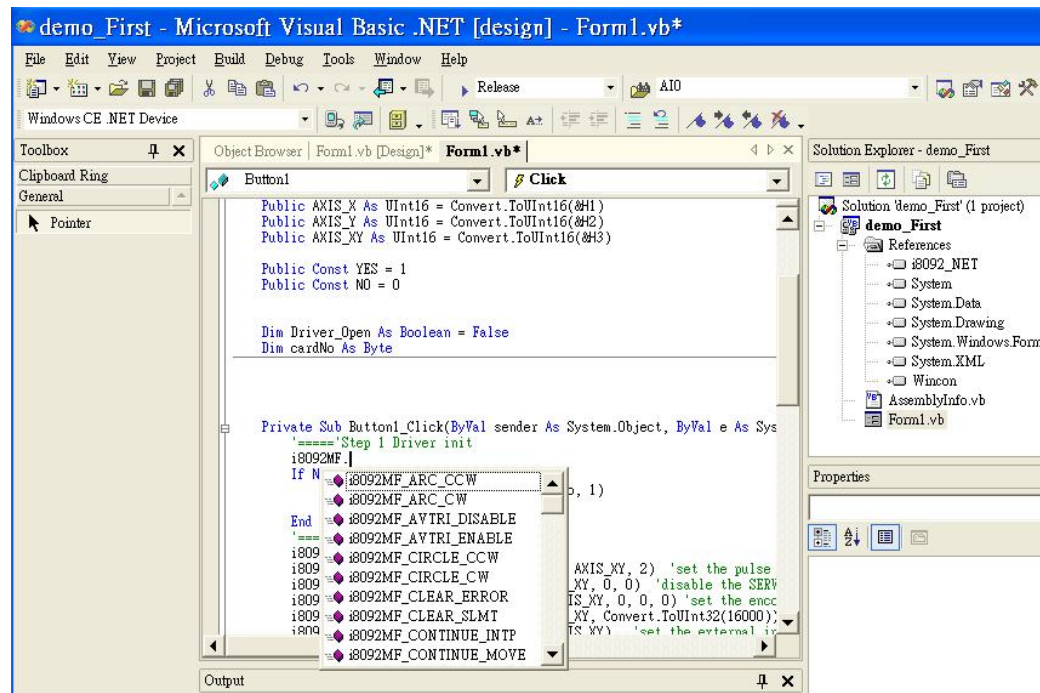

Detailed code as below:

'===='Step 1 Driver init

```

If Not Driver_Open Then
    i8092MF.i8092MF_REGISTRATION(cardNo, 1)
    Driver_Open = True
End If

'====='Step 2 CONFIG IO

i8092MF.i8092MF_RESET_CARD(cardNo)

i8092MF.i8092MF_SET_PULSE_MODE(cardNo, AXIS_XYZU, 2) 'set the pulse output mode
i8092MF.i8092MF_SET_ALARM(cardNo, AXIS_XYZU, 0, 0) 'disable the SERVO ALARM Input
i8092MF.i8092MF_SET_ENCODER(cardNo, AXIS_XYZU, 0, 0, 0) 'set the encoder input type
i8092MF.i8092MF_SET_MAX_V(cardNo, AXIS_XYZU, Convert.ToUInt32(16000)) 'set the max speed for XYZU
i8092MF.i8092MF_EXD_DISABLE(cardNo, AXIS_XYZU) 'set the external input Off
i8092MF.i8092MF_SET_LP(cardNo, AXIS_XYZU, 0) 'set the Logic position =0
i8092MF.i8092MF_SET_EP(cardNo, AXIS_XYZU, 0) 'set the Encogger position =0
i8092MF.i8092MF_SET_A(cardNo, AXIS_XYZU, Convert.ToUInt32(1000)) 'set the Acc =1000
i8092MF.i8092MF_SERVO_ON(cardNo, AXIS_XYZU) 'set the Servo_ON to servo motors

'====='Step 3 Check ERROR

Dim KK As Long = 0
KK = i8092MF.i8092MF_GET_ERROR(cardNo)

Dim MSGG As String
If (KK <> YES) Then
    'No ERROR: Step 4 Move X axis

    Dim axis As UInt16 = AXIS_X 'for AXIS_X it can be to AXIS_XYZU

    i8092MF.i8092MF_SET_MAX_V(cardNo, axis, Convert.ToUInt32(20000))

    i8092MF.i8092MF_NORMAL_SPEED(cardNo, axis, Convert.ToUInt16(0)) 'set axis as Symmetrical T curve
mode

    i8092MF.i8092MF_SET_V(cardNo, axis, Convert.ToUInt32(20000)) 'set v=10000 PPS
    i8092MF.i8092MF_SET_A(cardNo, axis, Convert.ToUInt32(100000)) 'set acc=100000 PPS/S
    i8092MF.i8092MF_SET_SV(cardNo, axis, Convert.ToUInt32(10)) 'set start speed=1000 PPS
    i8092MF.i8092MF_SET_AO(cardNo, axis, 0) 'set offset pulse (at SV speed)= 0 PS
    i8092MF.i8092MF_FIXED_MOVE(cardNo, axis, 10000) 'run the fixed 10000 Pulse move.

    Do While (i8092MF.i8092MF_STOP_WAIT(cardNo, axis) = NO)
        i8092MF.system.DoEvents()
        System.Threading.Thread.Sleep(1)

        'wait for axis to stop

    Loop

    Dim AA As Long = i8092MF.i8092MF_GET_LP(cardNo, axis) 'Get X Now position
Else

    'Please check the ERROR CODE

```

```
'Get X ERROR CODE
KK = Convert.ToInt32(i8092MF.i8092MF_GET_ERROR_CODE(cardNo, AXIS_X))
'Get Y ERROR CODE
KK = Convert.ToInt32(i8092MF.i8092MF_GET_ERROR_CODE(cardNo, AXIS_Y))
'Get Z ERROR CODE
KK = Convert.ToInt32(i8092MF.i8092MF_GET_ERROR_CODE(cardNo, AXIS_Z))
'Get U ERROR CODE
KK = Convert.ToInt32(i8092MF.i8092MF_GET_ERROR_CODE(cardNo, AXIS_U))
'=====
```

End If

Please refer to a example “demo_First”

4.2.5 Build the Project

Please select the “Build” -> ”Build Solution” in pull-down menu, then you will be finished this example program if there isn’t any wrong.

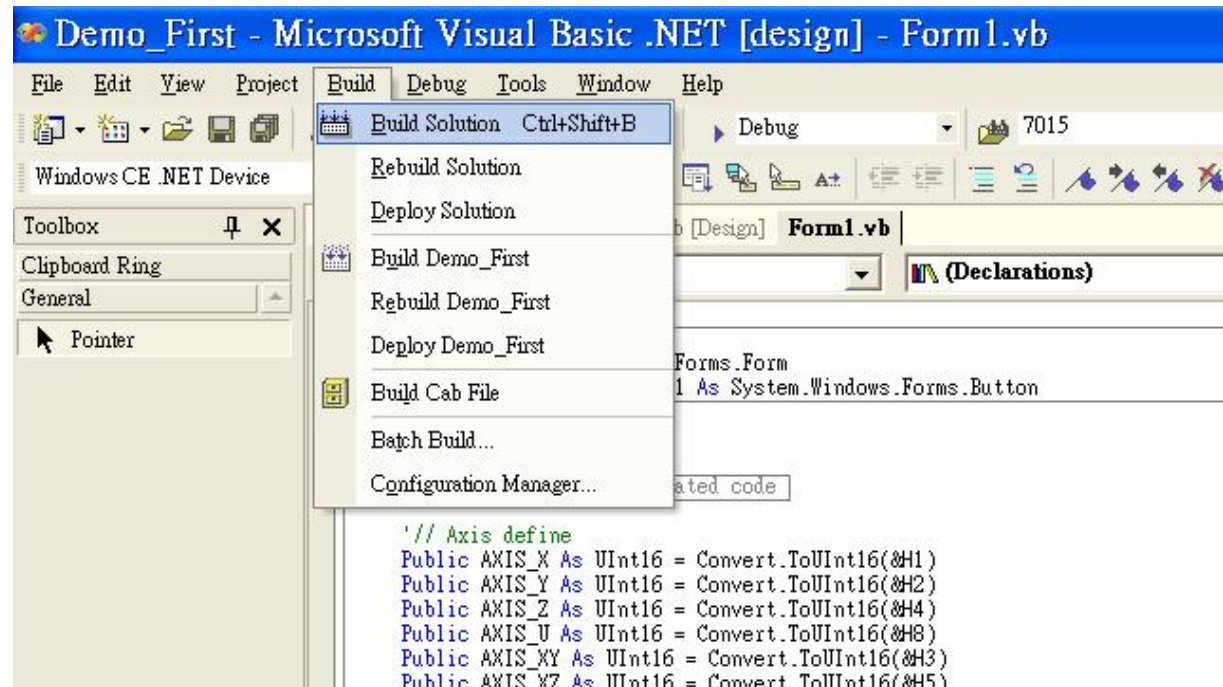

4.2.6 Download and Run

Please copy the "Demo_First.exe", "I8092.dll" and "I8092_NET.dll" into the same folder of WinCon (User can use the VS.NET Online Download/FTP/USB disk to do), then execute it.

4.3 I-8000 Turbo C Guideine

4.3.1 Confirm the Relative Files

Please confirm you have the following relevance files:

I8092.lib

I8092.h

I8000.lib

I8000.h

If you don't have, please look for CD or download the latest edition from ICPDAS's website <http://www.icpdas.com/download/download-list.htm>

4.3.2 Create a new TC ++ Application Project

1. Execute the TC.EXE in the demo100 folder, then create a new Project(demo100.prj).

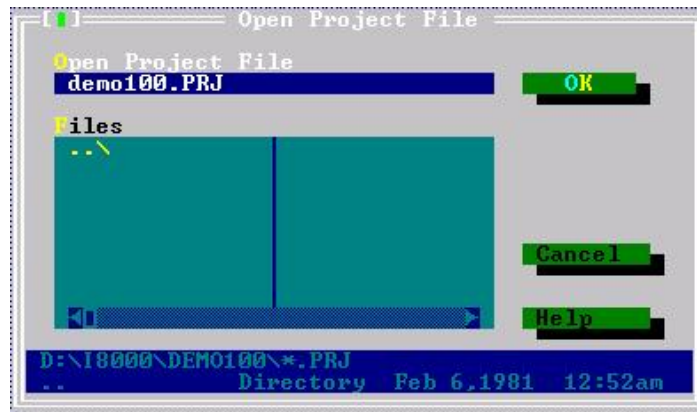

2. Add the contents of project : demo100.cpp and ..\lib\8000l.lib , 18092.lib

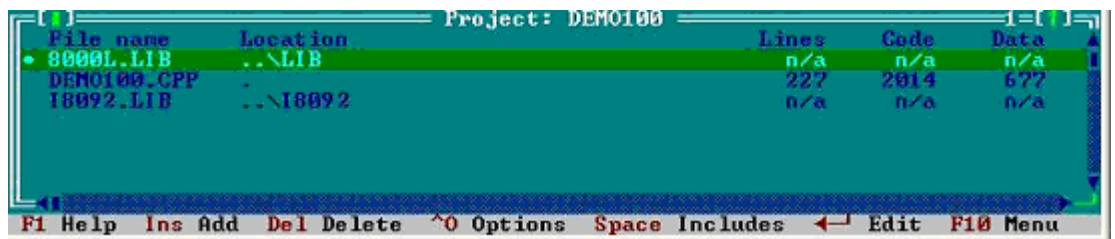

3. Setting the relevance option
 - Compiler -> Code Generation item as below :

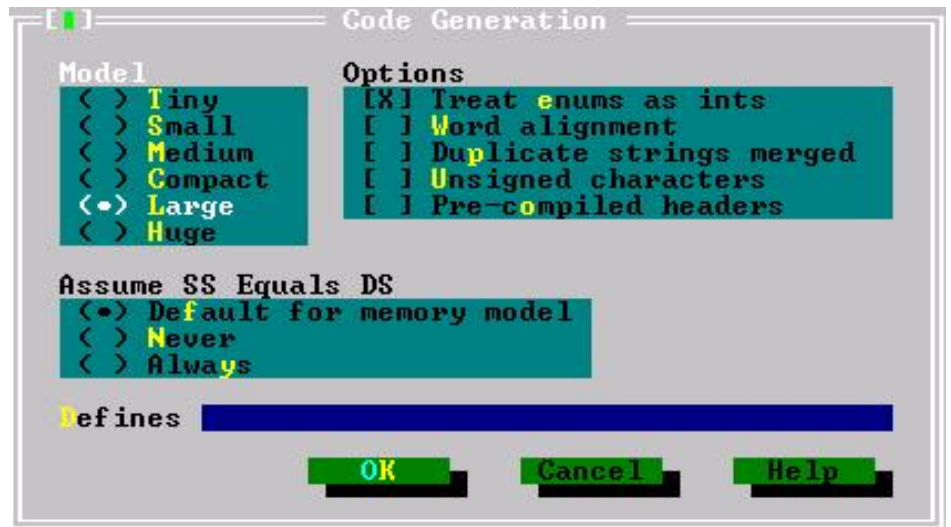

- Compiler -> Advance Code Generation item as below :

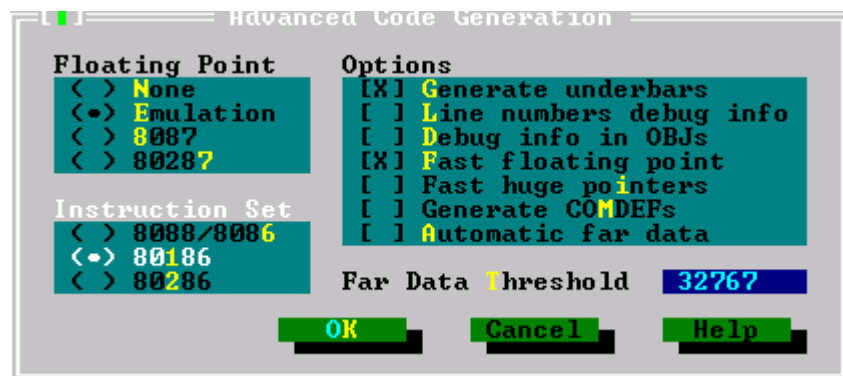

- Debugger setting as below, close the Source debugging.

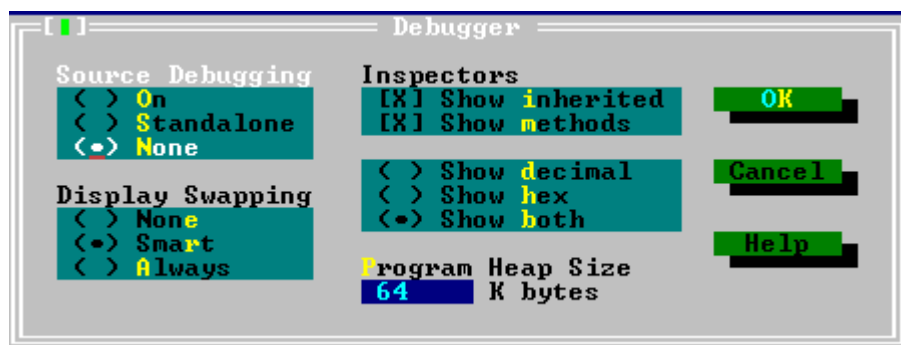

4.3.3 Start the TC Sample

1. Add the declared contents into the demo100.cpp:

```
#include <dos.h>
#include <math.h>
#include "8000.h"
#include "I8092.h"
BYTE cardNo;
long x_value, y_value, z_value, u_value;
```

2. Add the relevance code into the main program(Please refer to demo100.cpp):

```
void main ()
{
    //===== I-8000 =====
    //Set (slot0~slot7) = cardNO (1~8) ◦
    BYTE slot;
    int Found = 0;
    for (slot = 0; slot < 8; slot++)
    {
        cardNo = slot + 1;
        if (i8092MF_REGISTRATION(cardNo, slot) == YES)
        {
            //Found Axis Card ◦
            i8092MF_RESET_CARD(cardNo);
            Found++;
        }
    }
    if (Found == 0)
    {
        //Not Found ◦
        Print("I-8092 card not found ! \r\n");
    }
    return;
}

cardNo = 1;
i8092MF_INIT_CARD(cardNo);
i8092MF_SET_PULSE_MODE(cardNo, AXIS_XYZU, 2);
```



```

i8094_IN3_LEVEL(cardNo,AXIS_XYZU, 1);
i8092MF_SET_ALARM(cardNo, AXIS_XYZU, 1, 1);
i8092MF_SET_ENCODER(cardNo, AXIS_XYZU, 0, 0, 0);
i8092MF_SET_MAX_V(cardNo, AXIS_XYZU, 16000);

//=====================================================
BYTE ret1 = 0;
BYTE chkey;
DWORD sv; //PPS
DWORD v; //PPS
DWORD a; //PPS/s
i8092MF_SERVO_ON(cardNo, AXIS_XYZU);
do
{
    Print(" (0:Exit, 1:HELIX_3D_1, 2:HELIX_3D_2, 3:RATIO, 4:FRnet output, 5:FRnet input)
    \r\n");
    Print(" (6:Reset Encoder, 7:Stop, 8:Clear Error) \r\n");
    Print(" (X:Jog X, Y:Jog Y, Z:Jog Z, U:Jog U, S:Stop Jog) \r\n");
    Print("\n");
    Print("-----LOGIC AND REAL POSITION COUNTER-----\n");
    x_value = i8092MF_GET_LP(cardNo, AXIS_X);
    y_value = i8092MF_GET_LP(cardNo, AXIS_Y);
    z_value = i8092MF_GET_LP(cardNo, AXIS_Z);
    u_value = i8092MF_GET_LP(cardNo, AXIS_U);
    Print("LOGIC POSITION: x=%10ld, y= %10ld, z= %10ld, u=%10ld \r\n", x_value, y_value,
z_value, u_value);
    x_value = i8092MF_GET_EP(cardNo, AXIS_X);
    y_value = i8092MF_GET_EP(cardNo, AXIS_Y);
    z_value = i8092MF_GET_EP(cardNo, AXIS_Z);
    u_value = i8092MF_GET_EP(cardNo, AXIS_U);
    Print("REAL POSITION: x=%10ld, y= %10ld, z= %10ld, u=%10ld \r\n", x_value, y_value,
z_value, u_value);

    while (!Kbhit());
    chkey=Getch();
    Print("%s\r\n",&chkey);
    switch (chkey)
    {

```

```

case '0':

    i8092MF_RESET_CARD(cardNo);
    Print("EXIT! \r\n");
    return;

//-----

case '1':

    v=50000;//PPS ◦
    i8092MF_SET_MAX_V(cardNo, AXIS_XYZU,160000L);
    ret1=i8092MF_HELIX_3D(cardNo, AXIS_Y, AXIS_Z, AXIS_X, 1, v, 0,
1000, 5, -2000);

    Delay(1000);
    Print("HELIX_3D_1 ! \r\n");
    Print("ret1= %d \r\n",ret1);
    break;

//-----

case '2':

    v=100000;//PPS ◦
    i8092MF_SET_MAX_V(cardNo, AXIS_XYZU,1600000L);
    ret1=i8092MF_HELIX_3D(cardNo, AXIS_Y, AXIS_Z, AXIS_U, 1, v, 0,
25000, 10, 3600);

    Delay(2000);
    Print("HELIX_3D_2 ! \r\n");
    Print("ret1= %d \r\n",ret1);
    break;

//-----

case '3':

    sv=300;//PPS ◦
    v=30000;//PPS ◦
    a=500000;//PPS/s ◦
    int loop1;
    int loop2;
    float ratio;
    i8092MF_SET_MAX_V(cardNo, AXIS_XYZU,160000L);
    Print("RATIO_2D ratio ? \r\n");
    Scanf("%f", &ratio);
    Print("ratio= %f \r\n",ratio);
    i8092MF_RATIO_INITIAL(cardNo,AXIS_U, AXIS_X, sv, v, a, ratio);
    for (loop2 = 0; loop2 < 5; loop2++)

```

```

{
    for (loop1 = 0; loop1 < 5; loop1++)
    {
        i8092MF_RATIO_2D(cardNo, 0, 3600, 0);
        i8092MF_RATIO_2D(cardNo, 0, 3600, 1);
    }
    i8092MF_RATIO_2D(cardNo, 0, 7200, 0);
    i8092MF_RATIO_2D(cardNo, 0, 3600, 1);
}
i8092MF_RATIO_2D(cardNo, 1, 7200, 1);
Delay(3000);
Print("RATIO_2D OK ! \r\n");
break;

//-----
case '4':

    WORD wSA;
    WORD data;
    Print("FRnet wSA ? \r\n");
    Scanf("%d", &wSA);
    Print("FRnet 16 bits data ? \r\n");
    Scanf("%d", &data);
    i8092MF_FRNET_SA(cardNo, wSA, data);
    break;

//-----
case '5':

    WORD wRA;
    Print("FRnet wRA ? \r\n");
    Scanf("%d", &wRA);
    long data1 = i8092MF_FRNET_RA(cardNo, wRA);
    Print("FRnet 16 bits data = %10ld \r\n", data1);
    break;

//-----
case '6':

    i8092MF_SET_LP(cardNo, AXIS_XYZU, 0);
    i8092MF_SET_EP(cardNo, AXIS_XYZU, 0);
    Print("RESET Encoder ! \r\n");
    break;

//-----

```

```

case '7':
    i8092MF_STOP_SLOWLY(cardNo, AXIS_XYZU);
    Print("STOP! \r\n");
    break;

//-----
case '8':
    i8092MF_CLEAR_ERROR(cardNo);
    Print("CLEAR ERROR ! \r\n");
    break;

//-----
case 88:
case 120:
    BYTE m_Axis=AXIS_X;
    i8092MF_SET_MAX_V(cardNo, m_Axis, 32000);
    i8092MF_NORMAL_SPEED(cardNo, m_Axis, 0); //set axis as
Symmetrical T curve mode
    i8092MF_SET_A(cardNo, m_Axis, 50000); //set Acc =50000
PPS/S
    i8092MF_SET_V(cardNo, m_Axis, 50000);
    i8092MF_EXD_MP(cardNo, AXIS_X, 100);
    i8092MF_EXD_DISABLE(cardNo, AXIS_Y);
    i8092MF_EXD_DISABLE(cardNo, AXIS_Z);
    i8092MF_EXD_DISABLE(cardNo, AXIS_U);
    break;

//-----
case 89:
case 121:
    m_Axis=AXIS_Y;
    i8092MF_SET_MAX_V(cardNo, m_Axis, 32000);
    i8092MF_NORMAL_SPEED(cardNo, m_Axis, 0); //set axis as
Symmetrical T curve mode
    i8092MF_SET_A(cardNo, m_Axis, 50000); //set Acc =50000
PPS/S
    i8092MF_SET_V(cardNo, m_Axis, 100000);
    i8092MF_EXD_MP(cardNo, AXIS_Y, 100);
    i8092MF_EXD_DISABLE(cardNo, AXIS_X);
    i8092MF_EXD_DISABLE(cardNo, AXIS_Z);
    i8092MF_EXD_DISABLE(cardNo, AXIS_U);

```

```

break;
//-----
case 90:
case 122:
    m_Axis=AXIS_Z;
    i8092MF_SET_MAX_V(cardNo, m_Axis, 32000);
    i8092MF_NORMAL_SPEED(cardNo, m_Axis, 0); //set axis as
Symmetrical T curve mode
    i8092MF_SET_A(cardNo, m_Axis, 50000); //set Acc =50000
PPS/S
    i8092MF_SET_V(cardNo, m_Axis, 10000);
    i8092MF_EXD_MP(cardNo, AXIS_Z, 100);
    i8092MF_EXD_DISABLE(cardNo, AXIS_X);
    i8092MF_EXD_DISABLE(cardNo, AXIS_Y);
    i8092MF_EXD_DISABLE(cardNo, AXIS_U);
break;
//-----
case 85:
case 117:
    m_Axis=AXIS_U;
    i8092MF_SET_MAX_V(cardNo, m_Axis, 32000);
    i8092MF_NORMAL_SPEED(cardNo, m_Axis, 0); //set axis as
Symmetrical T curve mode
    i8092MF_SET_A(cardNo, m_Axis, 50000); //set Acc =50000
PPS/S
    i8092MF_SET_V(cardNo, m_Axis, 10000);
    i8092MF_EXD_MP(cardNo, AXIS_U, 5);
    i8092MF_EXD_DISABLE(cardNo, AXIS_X);
    i8092MF_EXD_DISABLE(cardNo, AXIS_Y);
    i8092MF_EXD_DISABLE(cardNo, AXIS_Z);
break;
//-----
case 83:
case 115:
    i8092MF_EXD_DISABLE(cardNo, AXIS_X);
    i8092MF_EXD_DISABLE(cardNo, AXIS_Y);
    i8092MF_EXD_DISABLE(cardNo, AXIS_Z);
    i8092MF_EXD_DISABLE(cardNo, AXIS_U);

```

```
        break;
    //-----
    default:
        break;
    }
} while (1);
}
```

4.3.4 Build the Project

Click F9 to compile program, LINK or demo100.EXE ◦

```
Linking
EXE file : ..\..\TCPP\DEM0100.EXE
Linking  : \TCPP\LIB\CL.LIB

      Total      Link
Lines compiled: 0      PASS 2
Warnings: 0      0
Errors: 0      0

Available memory: 1928K
Success : Press any key
```

4.3.6 Download and Run

1. Please execute the "7188.EXE" on computer (The "7188.EXE" is a executed file of DOS, it can be used in DOS or DOS BOX of Win9X/WINNT/WIN2K) .
2. Please depend on actual wiring "COM PORT" that assign to "COM1(ALT_1)" or "COM2(ALT_2)" and set the transmission speed to "115200,N,8,1".
3. Turn on the power of I-8000. It will have two situation :
 - It will appear a version of MiniOs7 message if the " INIT*" connected to " INIT*COM", then appear I-8000> ◦
 - The I-8000 will run the "AUTOEXEC.BAT" if the "INIT*" unconnected, then appear I-8000> ◦
4. User can start to make a command of I-8000 after appearing the "I-8000>", as below drawing:

```

7188XW 1.24 [COM4:115200,N,8,1],FC=0,CTS=1, DIR=C:\Progra...
7188x for WIN32 version 1.24 (10/31/2003) [By ICPDAS. Tim.]
Current set: Use COM4 115200,N,8,1
AutoRun:demo2.exe
Autodownload files: None
Current work directory="C:\Program Files\7188E\PCDiag"
original baudrate = 1200!
now baudrate = 115200!

ICP_DAS Minios7 for I-8000 Ver. 2.00 build 001,Mar 30 2004 17:30:23
SRAM:512K, FLASH MEMORY:512K
[CPU=Am188ES]
Serial number= 01 A3 A6 9F 09 00 00 62

i-8000>_

```

5. Press the F2 button on the keyboard, then key in "demo100.exe", then press the F10 button to download and execute demo100.exe, as following drawing:

```

7188XW 1.24 [COM4:115200,N,8,1],FC=0,CTS=1, DIR=C:\Progra...
now baudrate = 115200!

ICP_DAS Minios7 for I-8000 Ver. 2.00 build 001,Mar 30 2004 17:30:23
SRAM:512K, FLASH MEMORY:512K
[CPU=Am188ES]
Serial number= 01 A3 A6 9F 09 00 00 62

i-8000>
Input filename:demo100.exe
When Press F8/F9/F10 will auto download the file:demo100.exe
[F10]LOADR
Press ALT_E to download file!
Load file:demo100.exe [crc=4000,0000]
Send file info. total 432 blocks
Block 432
Transfer time is: 11.927000 seconds

i-8000>runr
(0:Exit, 1:HELIx_3D_1, 2:HELIx_3D_2, 3:RATIO, 4:Reset Encoder, 5:Stop, 6:Clear
Error)

-----LOGIC AND REAL POSITION COUNTER-----
LOGIC POSITION: x= -1598583, y= -1271690049, z= 1439068134, u=-191938561
REAL POSITION: x=-991053608, y= -280515019, z= 254699488, u=1876946677

```

Please refer to the 7188 getting started manual.

APPENDIX-A Setup Tools & Others

A.1 Setup the Development Environment of I8094

A.1.1 eVC ++ 4.0

1. Microsoft eVC++ 4.0: at least ServicPack2 (Have already got at present ServicPack4)
2. WinCon8000_EVC4_SP1: WinCon in eVC++ Development Environment (SA_IA)
3. WinConSDK:WinCon Software Tool(inc,lib,dll,demo...)

A.1.2 Visual Studio .NET 2003(VB.NET , C#)

1. Above Microsoft Visual Studio.NET 2003 professional, including a SmartDeviceApplication item
2. Debug Tool: Windows CE .NET Utilities v1.1 for Visual Studio .NET 2003
3. WinConSDK:WinCon software Tool(inc,lib,dll,demo...)

A.1.3 Turbo C

1. Above boland Turbo C 2.0

A.2 I8094 Surface



I-8092F motion module



WinCon W-8331, I-8092F and DN-8237

A.3 Dimensions

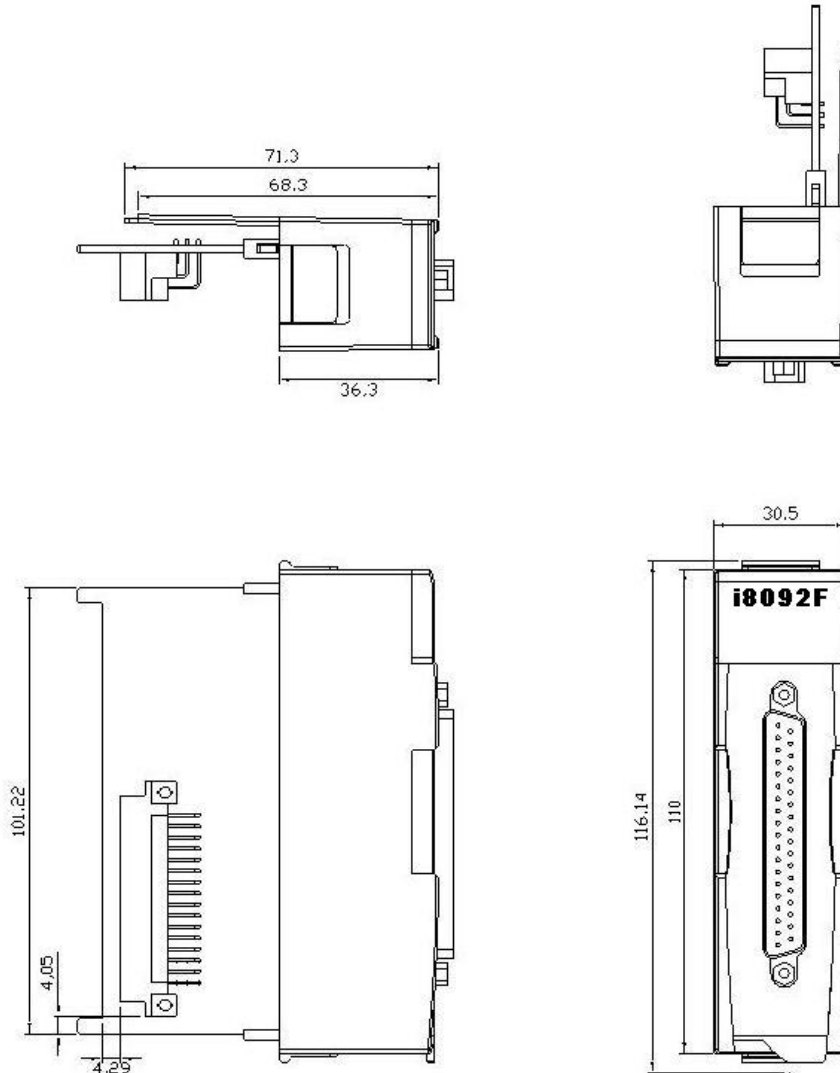

A.4 The Version Upgrades Note

New i8092.DLL

New i8092.h

New i8092_NET.DLL

APPENDIX B Other Terminal Boards

B.1 DN-8237-DB Daughter Board

The DN-8237DB is the daughter board for Delta ASDA-A Series Amplifier. It has 2-axis I/O signals.

B.1.1 Board Layout for DN-8237-DB

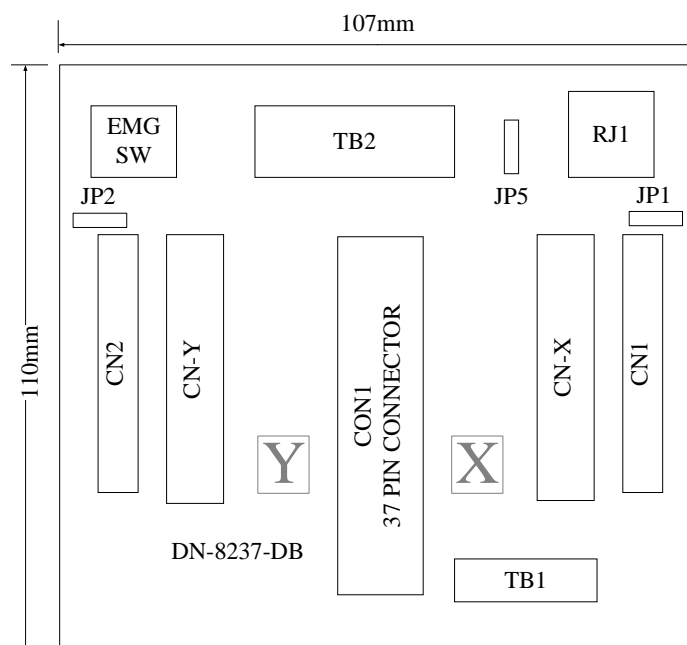

Fig. B1-1 Board layout for the DN-8237-DB

B.1.2 Signal Connections for DN-8237-DB

Maintaining signal connections is one of the most important factors in ensuring that your application system is sending and receiving data correctly.

■ Pin Assignment for CON1

The I/O connector on the DN-8237-DB is a 37-pin connector that enables you to connect to the PISO-PS200 or I-8092F motion card. Fig. B1-2 shows the pin assignment for the 37-pin I/O connector on the DN-8237-DB (or on the motion card), and refer to Table B1-2 for description of each motion I/O signal.

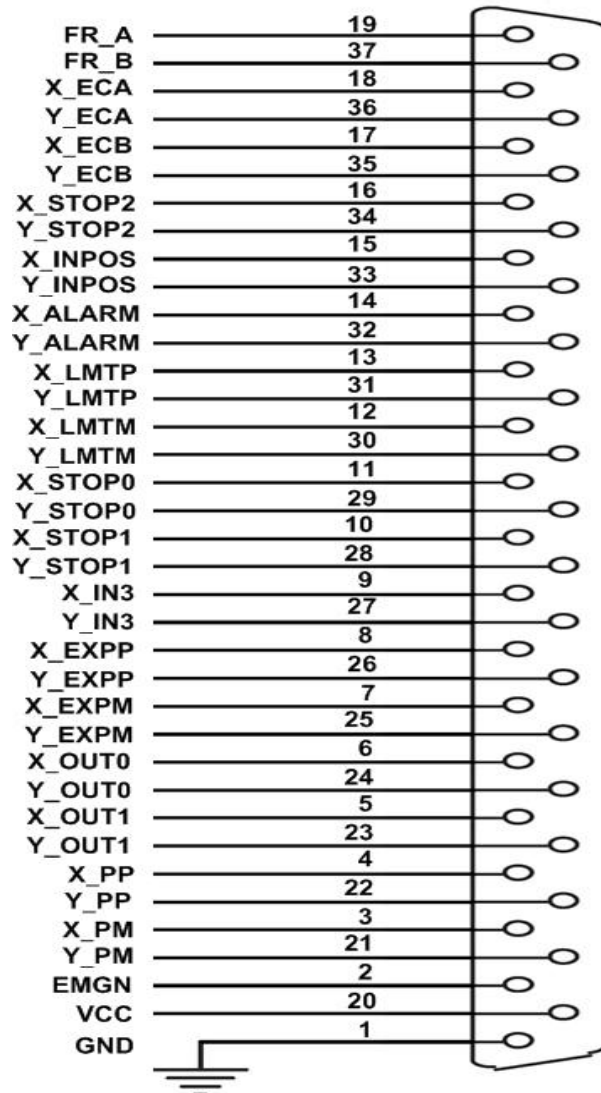

Fig. B1-2 I/O connector pin assignment for the CON1

Table B1-2 DN-8237-DB CON1 I/O connector signal description

Pin name	Pin number	Description
FR_A	19	FRnet A-phase signal
FR_B	37	FRnet B-phase signal
X_ECA	18	Encoder A-phase signal for the X axis
Y_ECA	36	Encoder A-phase signal for the Y axis
X_ECB	17	Encoder B-Phase signal for the X axis
Y_ECB	35	Encoder B-Phase signal for the Y axis
X_STOP2	16	Stop 2 signal for the X axis
Y_STOP2	34	Stop 2 signal for the Y axis
X_INPOS	15	In-position signal for the X axis
Y_INPOS	33	In-position signal for the Y axis
X_ALARM	14	Alarm signal for the X axis
Y_ALARM	32	Alarm signal for the Y axis
X_LMTP	13	Limit switch input signal (+) for the X axis
Y_LMTP	31	Limit switch input signal (+) for the Y axis
X_LMTM	12	Limit switch input signal (-) for the X axis
Y_LMTM	30	Limit switch input signal (-) for the Y axis
X_STOP0	11	Stop 0 signal for the X axis
Y_STOP0	29	Stop 0 signal for the Y axis
X_STOP1	10	Stop 1 signal for the X axis
Y_STOP1	28	Stop 1 signal for the Y axis
X_IN3	9	Input 3 signal for the X axis
Y_IN3	27	Input 3 signal for the Y axis
X_EXPP	8	EXT pulsar input signal (+) for the X axis
Y_EXPP	26	EXT pulsar input signal (+) for the Y axis
X_EXPM	7	EXT pulsar input signal (-) for the X axis
Y_EXPM	25	EXT pulsar input signal (-) for the Y axis
X_OUT0	6	Output 0 signal for the X axis
Y_OUT0	24	Output 0 signal for the Y axis
X_OUT1	5	Output 1 signal for the X axis
Y_OUT1	23	Output 1 signal for the Y axis
XPP	4	Driving pulsar signal (+) for the X axis
YPP	22	Driving pulsar signal (+) for the Y axis
XPM	3	Driving pulsar signal (+) for the X axis
YPM	21	Driving pulsar signal (+) for the Y axis
EMGN	2	Emergency stop input signal
VCC	20	Module power (+5V)
GND	1	Ground

■ TB1

The connector TB1 is 7-pin connector that enables you to connect to the signals of your motor drivers. Fig.B1-3 shows the pin assignment for the 7-pin connector on the DN-8237-DB, and the Table B1-3 shows its I/O connector signal description.

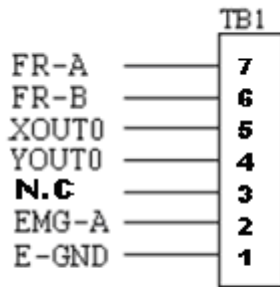

Fig. B1-3 Pin definition for TB1

Table B 1-3 TB1 Signal Connection

Name	Description
FR-A	FRnet port A
FR-B	FRnet port B
XOUT0	General Output 0 for X axis
YOUT0	General Output 0 for Y axis
N.C	No Connection
EMG-A	EMG input signal for all axes
E-GND	EXT power ground

■ TB2

The connector TB2 is 5-pin connector that enables you to connect to the signals of your motor drivers. Fig.B1-4 shows the pin assignment for the 5-pin connector on the DN-8237-DB, and the Table B1-4 shows its I/O connector signal description.

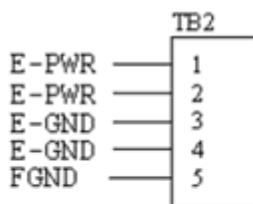

Fig. B1-4 Pin definition for TB2

Table B 1-4 TB2 Signal Connection

Pin name	Description
E-PWR	EXT power supply +24V
E-GND	EXT power ground
FGND	Frame ground

► **Note:** Don't reverse connect signals with E_PWR and E_GND. Serious damage to your motion card and motion controller might be happened.

■ **CN-X & CN-Y (CN1 connector for each AXIS in Driver)**

The connectors CN-X and CN-Y are 50-pin connectors that enable you to connect to the CN1 connector of Delta ASDA-A series motor drivers. Fig.B1-5 shows the pin assignment for the 50-pin connector on the DN-8468-DB, and the Table B1-5 shows its I/O connector signal description.

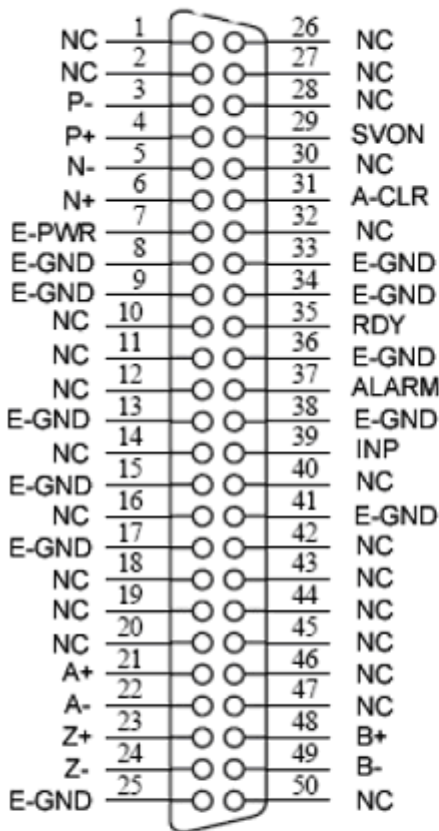

Fig. B1-5 Pin definition for CNX and CNY

Table B1-5 CN1 Signal Connection

Name	Number	Description
A+	21	Encoder A-Phase (+)
A-	22	Encoder A-Phase (-)
B+	48	Encoder B-Phase (+)
B-	49	Encoder B-Phase (-)
Z+	23	Encoder Z-Phase (+)
Z-	24	Encoder Z-Phase (-)
P+	4	Positive Direction Pulse Output(+)
P-	3	Positive Direction Pulse Output(-)
N+	6	Negative Direction Pulse
N-	5	Negative Direction Pulse Output(-)
INP	39	Servo In Position
RDY	35	Servo Ready
SVON	29	Servo On
A-CLR	31	Alarm Clear
ALARM	37	Servo Alarm
E-PWR	7	EXT power +24V
E-GND	8, 9, 13, 15, 17, 25, 33, 34, 36, 38, 41	EXT power ground
NC	1, 2, 10, 11, 12, 14, 16, 18, 19, 20, 26, 27, 28, 30, 32, 40, 42, 43, 44, 45, 46, 47, 50	No connection

► **Note 1:** Don't connect NC (not connected) signals. Connecting these signals could cause permanent damage to your motion controller.

■ CN1 & CN2 (The I/O signals of the X and Y AXIS)

The connectors CN1 and CN2 are 11-pin connectors that enable you to connect to the signals of your motor drivers. Fig.B1-6 shows the pin assignment for the 20-pin connector on the DN-8237-DB, and the Table B1-6 shows its I/O connector signal description.

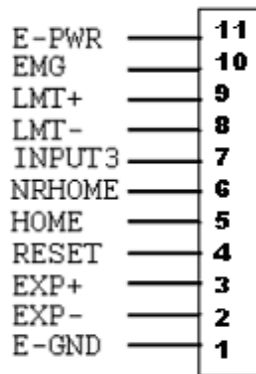

Fig. B1-6 Pin definition for CN1 & CN2

Table B1-6 CN1 & CN2 Signal Connection

Pin name	Description
E-PWR	EXT power supply +24V
EMG	EMG input signal
LMT+	Limit Switch Input Signal (+)
LMT-	Limit Switch Input Signal (-)
INPUT3	Input Signal (IN3)
NRHOME	Near Home Sensor Input Signal
HOME	Home Sensor Input Signal
RESET	Reset input signal
EXP+	EXT Positive Direction Pulse (+)
EXP-	EXT Negative Direction Pulse (-)
E-GND	EXT power ground

■ RJ1 (The I/O signals of the FRnet)

The connectors RJ1 is an 8-pin RJ45 connector that enable you to connect to the signals of FRnet. Fig.B1-7 shows the pin assignment for the 8-pin connector on the DN-8237-DB, and the Table B1-7 shows its I/O connector signal description.

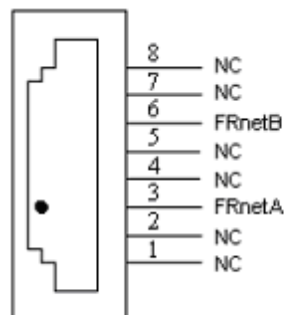

Fig. B1-7 Pin definition for RJ1

Table B1-7 RJ1

Pin name	Description
FRnetA	FRnet port A
FRnetB	FRnet port B
NC	No connection

► **Note:** Don't connect NC (not connected) signals. Connecting these signals could cause permanent damage to your motion controller.

B. 1. 3 Jumper and Switch Settings

■ JP5

Jumper 5 controls the EMG-A signal of the TB1 connector. The following diagram is shown the selection condition of the jumper 5.

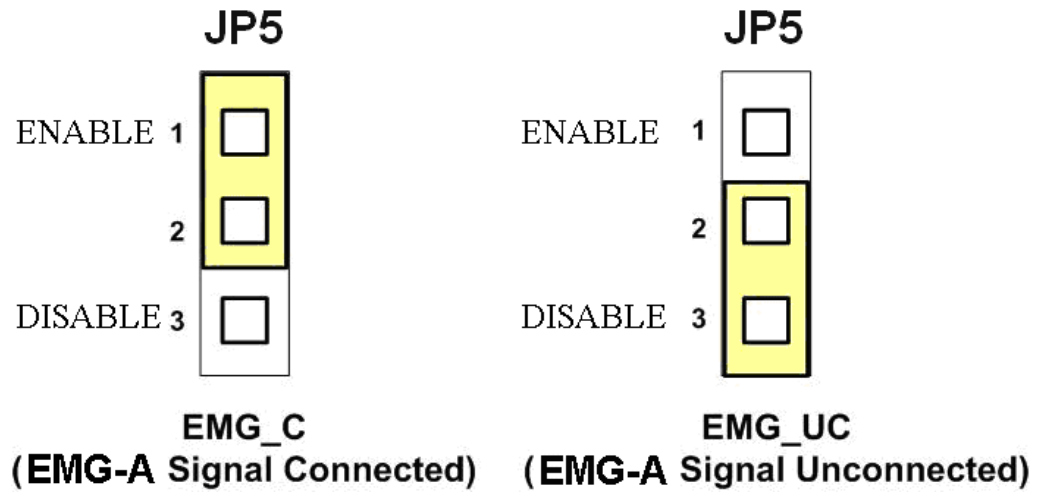

Fig. B1-8 Jumper 5 setting

■ SW 1

The emergency stop signal for each servo amplifier can be selected from SW1. The number 1 and 2 on SW1 are denoted as axis X and Y, respectively. The number 3 and 4 on SW1 are reserved for future work. Fig. B1-9 is the default setting to connect the EMG signals to GND. The EMG signals from CN1 and CN2 will not take effect. If the switch is disconnected as shown in Fig. B1-10, the emergency stop signals can be controlled from EMG signals in CN1 and CN2.

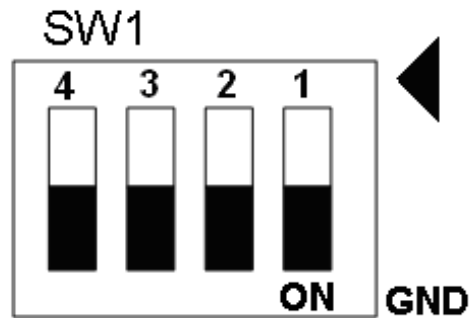

Fig. B1-9 SW1 setting for normally GND (Default setting)

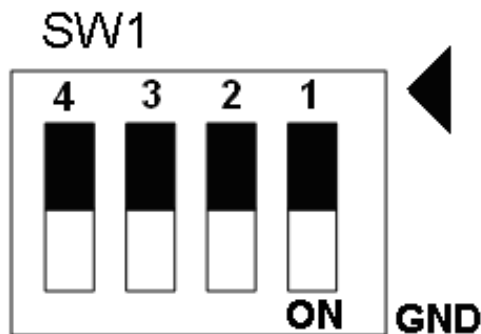

Fig. B1-10 SW1 setting for user controlled signals.

■ JP1 ~ JP2

Jumper 1 ~ Jumper 2 can select the reset function in CN1 and CN2 for each axis. The following diagram is shown the selection condition of the JP1.

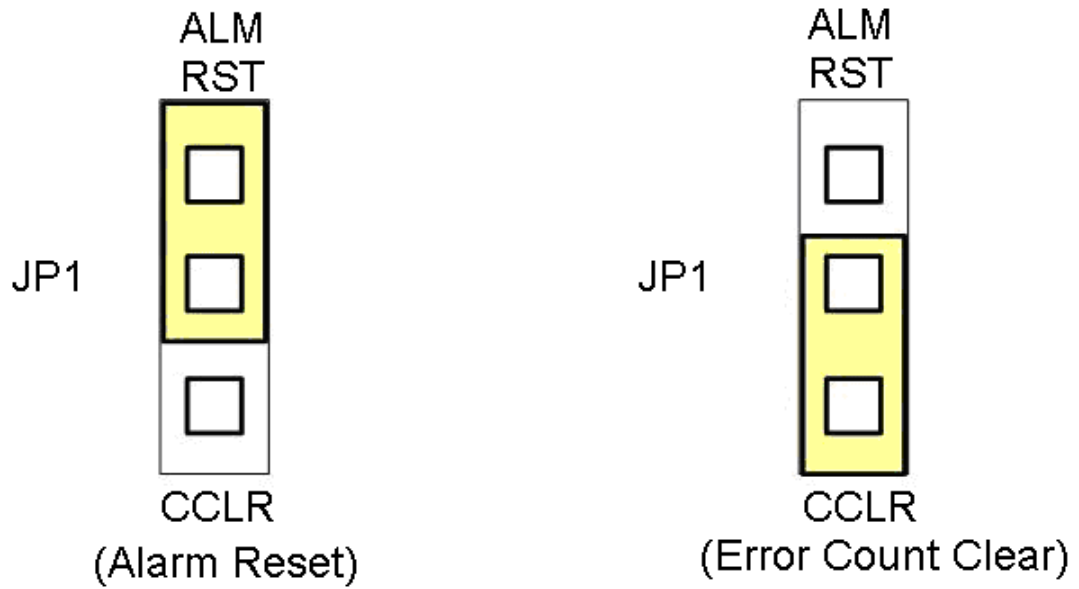

Fig. B1-15 JP 1 and 2 setting

B.2 DN-8237-MB Daughter Board

The DN-8237MB is the daughter board for Mitsubishi J2 Series Amplifier. It has 2-axis I/O signals.

B. 2. 1 Board Layout for DN-8237-MB

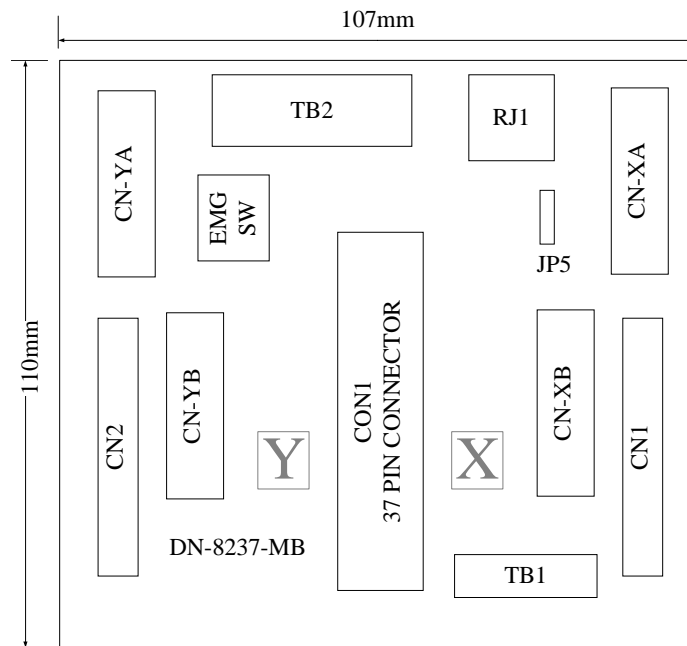

Fig. B2-1 Board layout for the DN-8237-MB

B. 2. 2 Signal Connections for DN-8237-MB

Maintaining signal connections is one of the most important factors in ensuring that your application system is sending and receiving data correctly.

■ Pin Assignment for CON1

The I/O connector on the DN-8237-MB is a 37-pin connector that enables you to connect to the PISO-PS200 or I-8092F motion card. Fig. B2-2 shows the pin assignment for the 37-pin I/O connector on the DN-8237-MB (or on the motion card), and refer to Table B2-2 for description of each motion I/O signal.

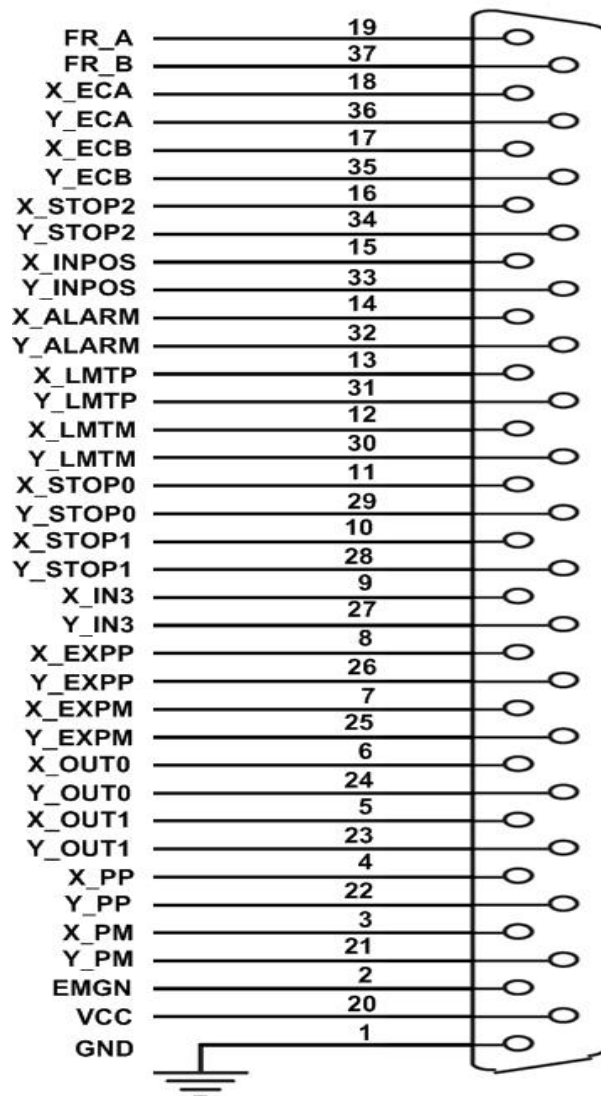

Fig. B2-2 I/O connector pin assignment for the CON1

Table B2-2 DN-8237-MB CON1 I/O connector signal description

Pin name	Pin number	Description
FR_A	19	FRnet A-phase signal
FR_B	37	FRnet B-phase signal
X_ECA	18	Encoder A-phase signal for the X axis
Y_ECA	36	Encoder A-phase signal for the Y axis
X_ECB	17	Encoder B-Phase signal for the X axis
Y_ECB	35	Encoder B-Phase signal for the Y axis
X_STOP2	16	Stop 2 signal for the X axis
Y_STOP2	34	Stop 2 signal for the Y axis
X_INPOS	15	In-position signal for the X axis
Y_INPOS	33	In-position signal for the Y axis
X_ALARM	14	Alarm signal for the X axis
Y_ALARM	32	Alarm signal for the Y axis
X_LMTP	13	Limit switch input signal (+) for the X axis
Y_LMTP	31	Limit switch input signal (+) for the Y axis
X_LMTM	12	Limit switch input signal (-) for the X axis
Y_LMTM	30	Limit switch input signal (-) for the Y axis
X_STOP0	11	Stop 0 signal for the X axis
Y_STOP0	29	Stop 0 signal for the Y axis
X_STOP1	10	Stop 1 signal for the X axis
Y_STOP1	28	Stop 1 signal for the Y axis
X_IN3	9	Input 3 signal for the X axis
Y_IN3	27	Input 3 signal for the Y axis
X_EXPP	8	EXT pulsar input signal (+) for the X axis
Y_EXPP	26	EXT pulsar input signal (+) for the Y axis
X_EXPM	7	EXT pulsar input signal (-) for the X axis
Y_EXPM	25	EXT pulsar input signal (-) for the Y axis
X_OUT0	6	Output 0 signal for the X axis
Y_OUT0	24	Output 0 signal for the Y axis
X_OUT1	5	Output 1 signal for the X axis
Y_OUT1	23	Output 1 signal for the Y axis
XPP	4	Driving pulsar signal (+) for the X axis
YPP	22	Driving pulsar signal (+) for the Y axis
XPM	3	Driving pulsar signal (+) for the X axis
YPM	21	Driving pulsar signal (+) for the Y axis
EMGN	2	Emergency stop input signal
VCC	20	Module power (+5V)
GND	1	Ground

■ TB2

The connector TB2 is 7-pin connector that enables you to connect to the signals of your motor drivers. Fig.B2-3 shows the pin assignment for the 7-pin connector on the DN-8237-MB, and the Table B2-3 shows its I/O connector signal description.

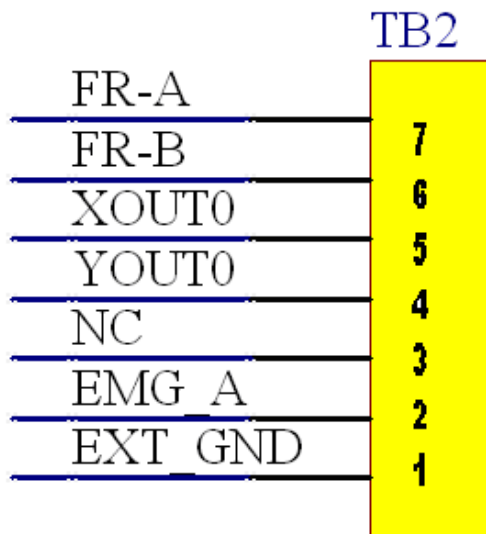

Table B2-3 TB2 Signal Connection

Name	Number	Description
FR-A	7	FRnet port A
FR-B	6	FRnet port B
XOUT0	5	General output 0 for X axis
YOUT0	4	General output 0 for X axis
NC	3	No connection
EMG-A	2	EMG input signal for all axis
EXT_GND	1	EXT POWER Ground

Fig B2-3 Pin definition for TB2

■ TB1

The connector TB1 is 5-pin connector that enables you to connect to the signals of your motor drivers. Fig.B2-4 shows the pin assignment for the 5-pin connector on the DN-8237-MB, and the Table B2-4 shows its I/O connector signal description.

Table B2-4 TB1 Signal Connection

Name	Number	Description
EXT_PWR	1	EXT POWER 24V
EXT_PWR	2	EXT POWER 24V
EXT_GND	3	EXT POWER Ground
EXT_GND	4	EXT POWER Ground
FGND	5	Frame Ground

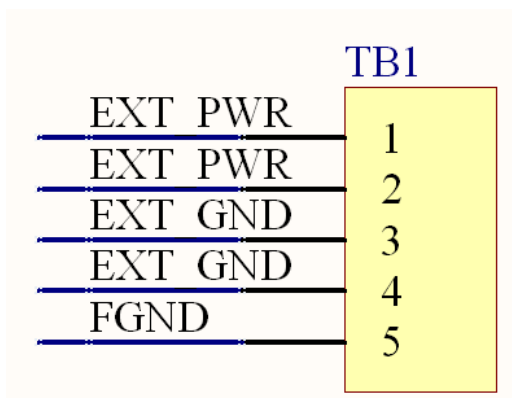

Fig B2-4 Pin definition for TB1

► **Note:** Don't reverse connect signals with E_PWR and E_GND. Serious damage to your motion card and motion controller might be happened.

■ **CN-XA & CN-YA (Fig B2-5 connector for each AXIS)**

The connectors CN-XA and CN-YA are 20-pin connectors that enable you to connect to the CNA connector of Mitsubishi motor drivers. Fig.B2-5 shows the pin assignment for the 20-pin connector on the DN-8237-MB, and the Table B2-5 shows its I/O connector signal description.

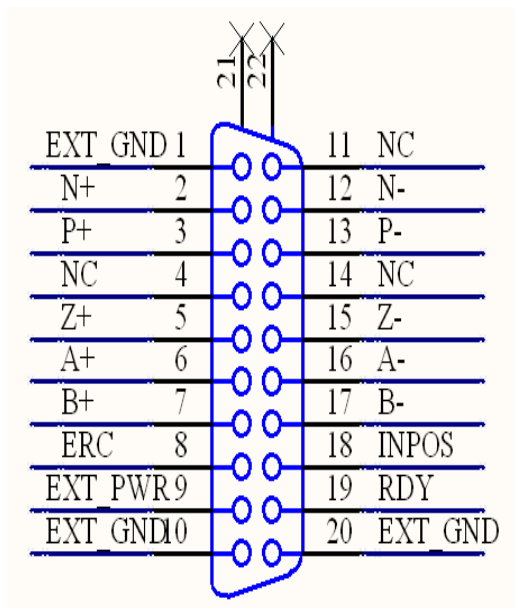

Fig B2-5 Pin definition for CN-XA, CN-YA

Table B2-5 CN-X A,CN-YA

Name	Number	Description
EXT_GND	1	EXT POWER Ground
N+	2	Negative Direction Pulse(+)
P+	3	Positive Direction Pulse(+)
NC	4	No connection
Z+	5	Encoder Z-phase(+)
A+	6	Encoder A-phase(+)
B+	7	Encoder B-phase(+)
ERC	8	Error Count Clear
EXT_PWR	9	EXT POWER 24V
EXT_GND	10	EXT POWER Ground
NC	11	No connection
N-	12	Negative Direction Pulse(-)
P-	13	Positive Direction Pulse (-)
NC	14	No connection
Z-	15	Encoder Z-phase(-)
A-	16	Encoder A-phase (-)
B-	17	Encoder B-phase (-)
INPOS	18	Servo In Position
RDY	19	Servo Ready
EXT_GND	20	EXT POWER Ground

► **Note 1:** Don't connect NC (not connected) signals. Connecting these signals could cause permanent damage to your motion controller.

■ **CN-XB & CN-YB (Fig B2-6 connector for each AXIS)**

The connectors CN-XB and CN-YB are 20-pin connectors that enable you to connect to the CNB connector of your motor drivers. Fig.B2-6 shows the pin assignment for the 20-pin connector on the DN-8237-MB, and the Table B2-6 shows its I/O connector signal description.

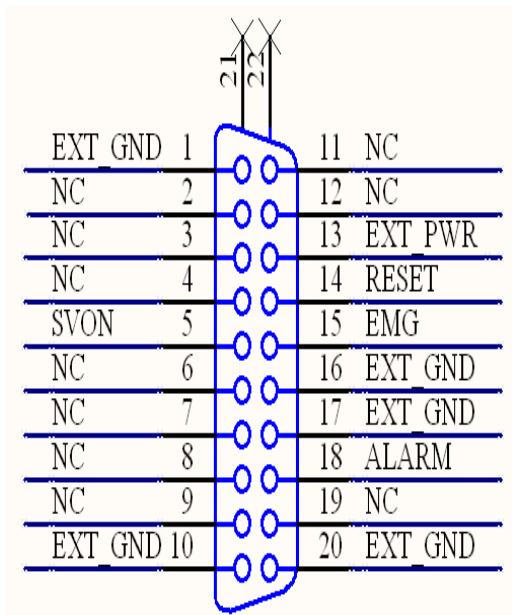

Fig B2-6 Pin definition for CN-XB, CN-YB

Table B2-6 CN-XB ,CN-YB

Name	Number	Description
EXT_GND	1	EXT POWER Ground
NC	2	No connection
NC	3	No connection
NC	4	No connection
SVON	5	Servo On
NC	6	No connection
NC	7	No connection
NC	8	No connection
NC	9	No connection
EXT_GND	10	EXT POWER Ground
NC	11	No connection
NC	12	No connection
EXT_PWR	13	EXT POWER 24V
RESET	14	Servo Reset
EMG	15	Emergent Stop
EXT_GND	16	EXT POWER Ground
EXT_GND	17	EXT POWER Ground
ALARM	18	Servo Alarm
NC	19	No connection
EXT_GND	20	EXT POWER Ground

► **Note 1:** Don't connect NC (not connected) signals. Connecting these signals could cause permanent damage to your motion controller.

■ **CN1 & CN2 (The I/O signals of the X and Y AXIS)**

The connectors CN1 and CN2 are 11-pin connectors that enable you to connect to the signals of your motor drivers. Fig.B2-7 shows the pin assignment for the 20-pin connector on the DN-8237-MB, and the Table B2-7 shows its I/O connector signal description.

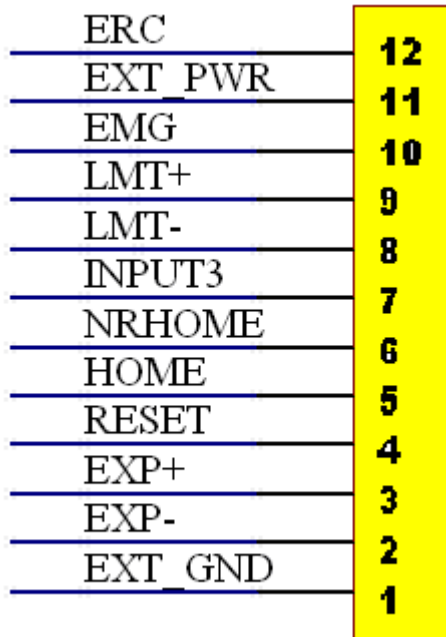

Table B2-7 CN1~CN2

Name	Number	Description
ERC	12	Error Count Clear
EXT_PWR	11	EXT POWER 24V
EMG	10	Emergent Stop
LMT+	9	Limit switch Input Signal(+)
LMT-	8	Limit switch Input Signal(-)
INPUT3	7	Input Signal (IN3)
NRHOME	6	Near HOME Sensor Input Signal
HOME	5	HOME Sensor Input Signal
RESET	4	RESET Input Signal
EXP+	3	EXT Positive Direction Pulse(+)
EXP-	2	EXT Positive Direction Pulse(-)
EXT_GND	1	EXT POWER Ground

Fig B2-7 Pin definition for CN1~ CN2

■ RJ1 (The I/O signals of the FRnet)

The connectors RJ1 is an 8-pin RJ45 connector that enable you to connect to the signals of FRnet. Fig.B2-8 shows the pin assignment for the 8-pin connector on the DN-8237-MB, and the Table B2-8 shows its I/O connector signal description.

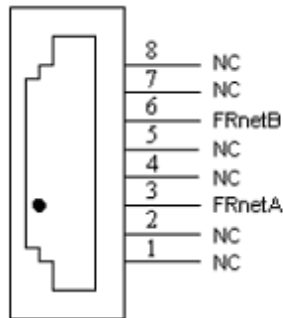

Pin name	Description
FRnetA	FRnet port A
FRnetB	FRnet port B
NC	No connection

Fig. B2-8 Pin definition for RJ1

► **Note:** Don't connect NC (not connected) signals. Connecting these signals could cause permanent damage to your motion controller.

B2.3 Jumper and Switch Settings

■ JP5

Jumper 5 controls the EMG-A signal of the TB1 connector. The following diagram is shown the selection condition of the jumper 5.

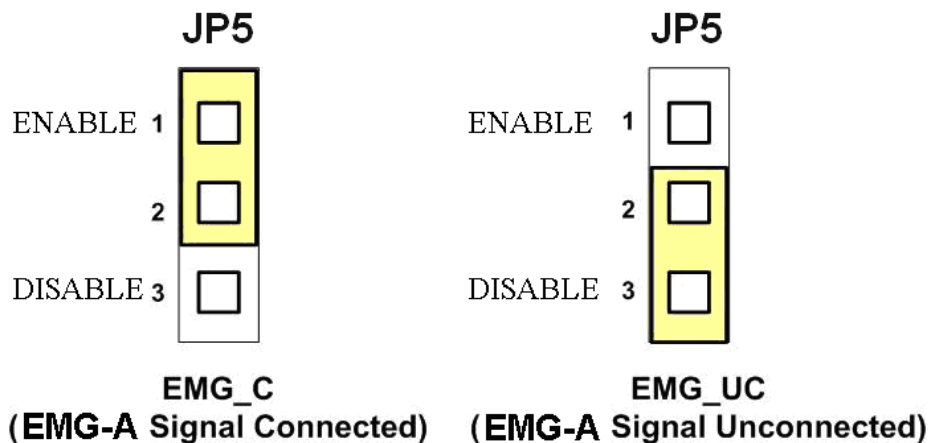

Fig. B2-9 Jumper 5 setting

■ SW 1

The emergency stop signal for each servo amplifier can be selected from SW1. The number 1 and 2 on SW1 are denoted as axis X and Y, respectively. The number 3 and 4 on SW1 are reserved for future work. Fig. B2-10 is the default setting to connect the EMG signals to GND. The EMG signals from CN1 and CN2 will not take effect. If the switch is disconnected as shown in Fig. B2-11, the emergency stop signals can be controlled from EMG signals in CN1 and CN2.

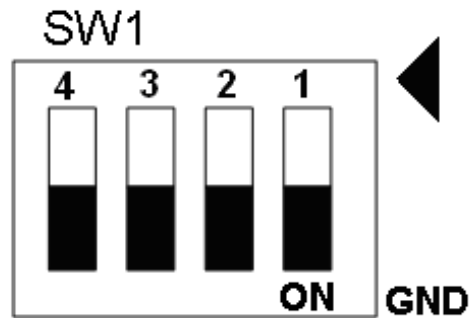

Fig. B2-10 SW1 setting for normally GND (Default setting)

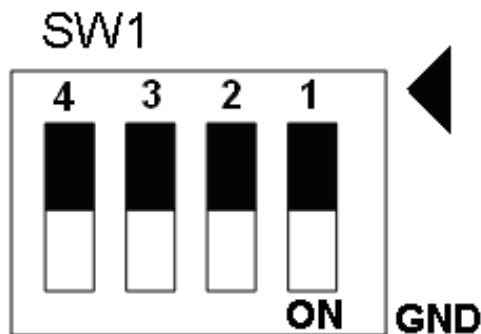

Fig. B2-11 SW1 setting for user controlled signals.

B.3 DN-8237-PB Daughter Board

The DN-8237PB is the daughter board for Panasonic A4 Series Amplifier. It has 2-axis I/O signals.

B.3.1 Board Layout for DN-8237-PB

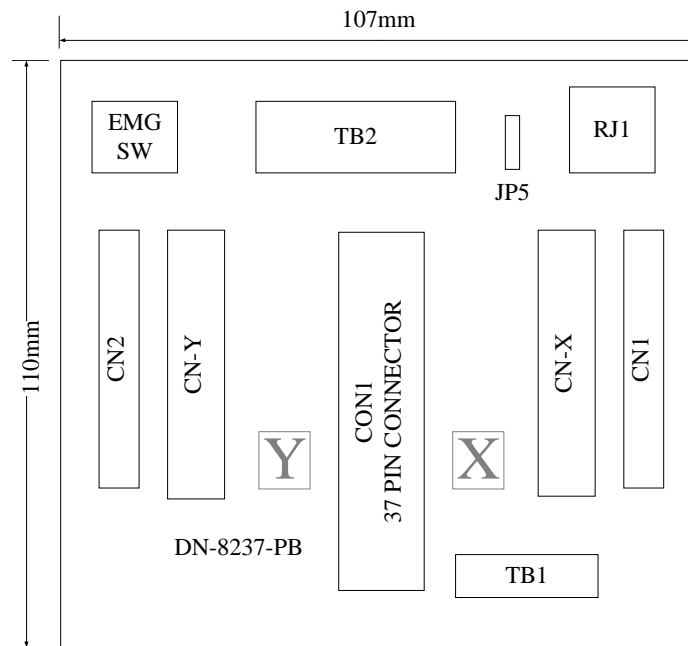

Fig. B3-1 Board layout for the DN-8237-PB

B. 3. 2 Signal Connections for DN-8237-PB

Maintaining signal connections is one of the most important factors in ensuring that your application system is sending and receiving data correctly.

■ Pin Assignment for CON1

The I/O connector on the DN-8237-PB is a 37-pin connector that enables you to connect to the PISO-PS200(or I-8092F) motion card. Fig. B3-2 shows the pin assignment for the 37-pin I/O connector on the DN-8237-PB (or on the motion card), and refer to Table B3-2 for description of each motion I/O signal.

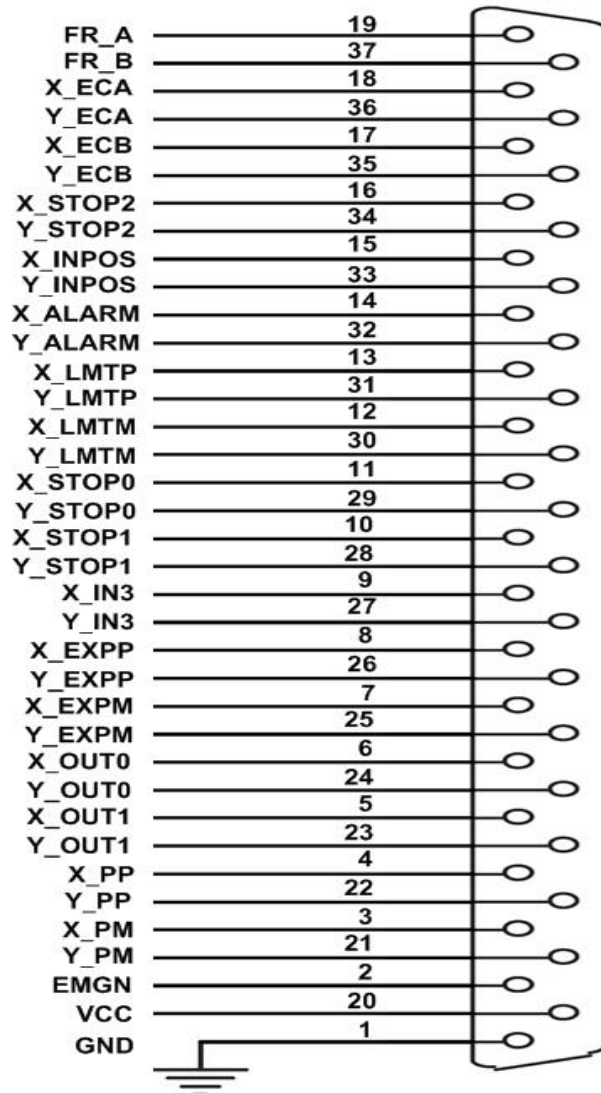

Fig. B3-2 I/O connector pin assignment for the CON1

Table B3-2 DN-8237-PB CON1 I/O connector signal description

Pin name	Pin number	Description
FR_A	19	FRnet A-phase signal
FR_B	37	FRnet B-phase signal
X_ECA	18	Encoder A-phase signal for the X axis
Y_ECA	36	Encoder A-phase signal for the Y axis
X_ECB	17	Encoder B-Phase signal for the X axis
Y_ECB	35	Encoder B-Phase signal for the Y axis
X_STOP2	16	Stop 2 signal for the X axis
Y_STOP2	34	Stop 2 signal for the Y axis
X_INPOS	15	In-position signal for the X axis
Y_INPOS	33	In-position signal for the Y axis
X_ALARM	14	Alarm signal for the X axis
Y_ALARM	32	Alarm signal for the Y axis
X_LMTP	13	Limit switch input signal (+) for the X axis
Y_LMTP	31	Limit switch input signal (+) for the Y axis
X_LMTM	12	Limit switch input signal (-) for the X axis
Y_LMTM	30	Limit switch input signal (-) for the Y axis
X_STOP0	11	Stop 0 signal for the X axis
Y_STOP0	29	Stop 0 signal for the Y axis
X_STOP1	10	Stop 1 signal for the X axis
Y_STOP1	28	Stop 1 signal for the Y axis
X_IN3	9	Input 3 signal for the X axis
Y_IN3	27	Input 3 signal for the Y axis
X_EXPP	8	EXT pulsar input signal (+) for the X axis
Y_EXPP	26	EXT pulsar input signal (+) for the Y axis
X_EXPM	7	EXT pulsar input signal (-) for the X axis
Y_EXPM	25	EXT pulsar input signal (-) for the Y axis
X_OUT0	6	Output 0 signal for the X axis
Y_OUT0	24	Output 0 signal for the Y axis
X_OUT1	5	Output 1 signal for the X axis
Y_OUT1	23	Output 1 signal for the Y axis
XPP	4	Driving pulsar signal (+) for the X axis
YPP	22	Driving pulsar signal (+) for the Y axis
XPM	3	Driving pulsar signal (+) for the X axis
YPM	21	Driving pulsar signal (+) for the Y axis
EMGN	2	Emergency stop input signal
VCC	20	Module power (+5V)
GND	1	Ground

■ TB1

The connector TB1 is 7-pin connector that enables you to connect to the signals of your motor drivers. Fig.B3-3 shows the pin assignment for the 7-pin connector on the DN-8237-PB, and the Table B3-3 shows its I/O connector signal description.

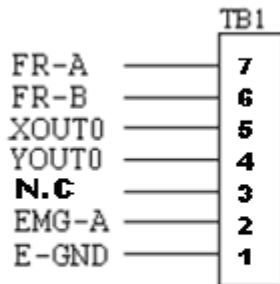

Fig. B3-3 Pin definition for TB1

TableB3-3 TB1 Signal Connection

Name	Description
FR-A	FRnet port A
FR-B	FRnet port B
XOUT0	General Output 0 for X axis
YOUT0	General Output 0 for Y axis
N.C	No Connection
EMG-A	EMG input signal for all axes
E-GND	EXT power ground

■ TB2

The connector TB2 is 5-pin connector that enables you to connect to the signals of your motor drivers. Fig.B3-4 shows the pin assignment for the 5-pin connector on the DN-8237-PB, and the Table B3-4 shows its I/O connector signal description.

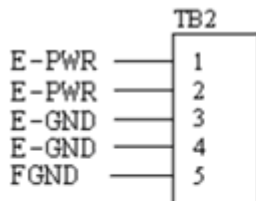

Fig. B3-4 Pin definition for TB2

Table B3-4 TB2 Signal Connection

Pin name	Description
E-PWR	EXT power supply +24V
E-GND	EXT power ground
FGND	Frame ground

► **Note:** Don't reverse connect signals with E_PWR and E_GND. Serious damage to your motion card and motion controller might be happened.

■ **CN-X & CN-Y (CN X5 connector for each Axis in Driver)**

The connectors CN-X and CN-Y are 50-pin connectors that enable you to connect to the CN X5 connector of Panasonic motor drivers. Fig.B3-5 shows the pin assignment for the 50-pin connector on the DN-8468-PB, and the Table B3-5 shows its I/O connector signal description.

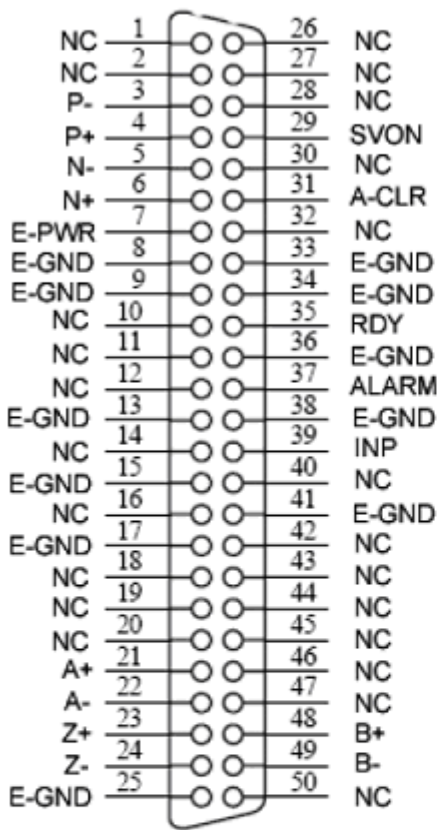

Fig. B3-5 Pin definition for CNX and CNY

Table B3-5 CN X5 Signal Connection

Name	Number	Description
A+	21	Encoder A-Phase (+)
A-	22	Encoder A-Phase (-)
B+	48	Encoder B-Phase (+)
B-	49	Encoder B-Phase (-)
Z+	23	Encoder Z-Phase (+)
Z-	24	Encoder Z-Phase (-)
P+	4	Positive Direction Pulse Output(+)
P-	3	Positive Direction Pulse Output(-)
N+	6	Negative Direction Pulse
N-	5	Negative Direction Pulse Output(-)
INP	39	Servo In Position
RDY	35	Servo Ready
SVON	29	Servo On
A-CLR	31	Alarm Clear
ALARM	37	Servo Alarm
E-PWR	7	EXT power +24V
E-GND	8, 9, 13, 15, 17, 25, 33, 34, 36, 38, 41	EXT power ground
NC	1, 2, 10, 11, 12, 14, 16, 18, 19, 20, 26, 27, 28, 30, 32, 40, 42, 43, 44, 45, 46, 47, 50	No connection

► **Note 1:** Don't connect NC (not connected) signals. Connecting these signals could cause permanent damage to your motion controller.

■ CN1& CN2 (The I/O signals of the X and Y axis)

The connectors CN1 and CN2 are 11-pin connectors that enable you to connect to the signals of your motor drivers. Fig.B3-6 shows the pin assignment for the 20-pin connector on the DN-8237-PB, and the Table B3-6 shows its I/O connector signal description.

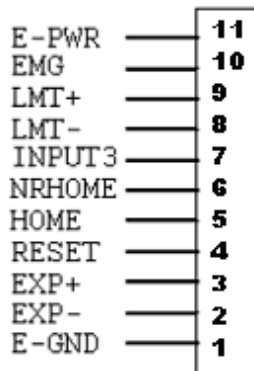

Fig B3-6 Pin definition for CN1 & CN2

Table B3-6 CN1 & CN2 Signal Connection

Pin name	Description
E-PWR	EXT power supply +24V
EMG	EMG input signal
LMT+	Limit Switch Input Signal (+)
LMT-	Limit Switch Input Signal (-)
INPUT3	Input Signal (IN3)
NRHOME	Near Home Sensor Input Signal
HOME	Home Sensor Input Signal
RESET	Reset input signal
EXP+	EXT Positive Direction Pulse (+)
EXP-	EXT Negative Direction Pulse (-)
E-GND	EXT power ground

■ RJ1 (The I/O signals of the FRnet)

The connectors RJ1 is an 8-pin RJ45 connector that enable you to connect to the signals of FRnet. Fig.B3-7 shows the pin assignment for the 8-pin connector on the DN-8237-PB, and the Table B3-7 shows its I/O connector signal description.

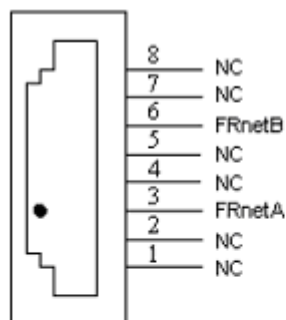

Fig. B3-7 Pin definition for RJ1

Table B3-7 RJ1

Pin name	Description
FRnetA	FRnet port A
FRnetB	FRnet port B
NC	No connection

► **Note:** Don't connect NC (not connected) signals. Connecting these signals could cause permanent damage to your motion controller.

B. 3. 3 Jumper and Switch Settings

■ JP5

Jumper 5 controls the EMG-A signal of the TB1 connector. The following diagram is shown the selection condition of the jumper 5.

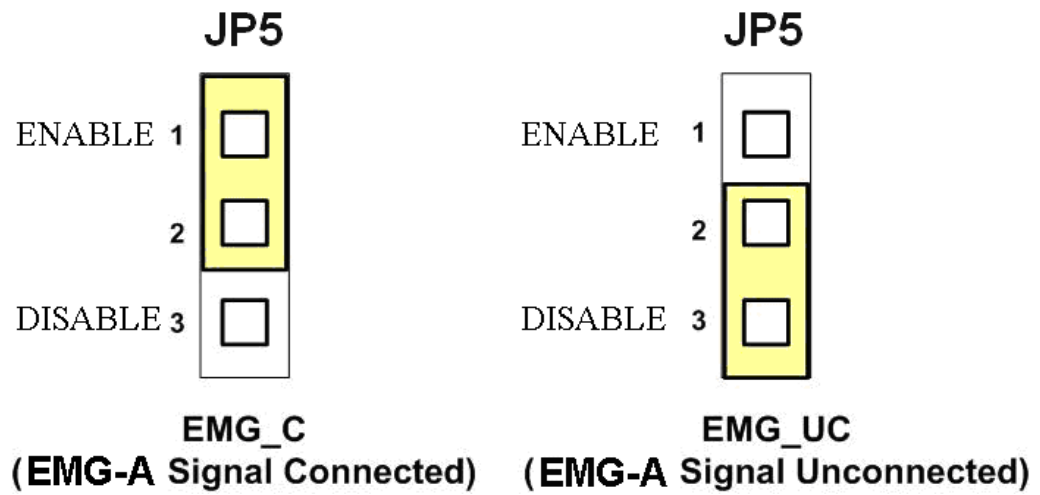

Fig. B3-8 Jumper 5 setting

■ SW 1

The emergency stop signal for each servo amplifier can be selected from SW1. The number 1 and 2 on SW1 are denoted as axis X and Y, respectively. The number 3 and 4 on SW1 are reserved for future work. Fig. B3-9 is the default setting to connect the EMG signals to GND. The EMG signals from CN1 and CN2 will not take effect. If the switch is disconnected as shown in Fig. B3-10, the emergency stop signals can be controlled from EMG signals in CN1 and CN2.

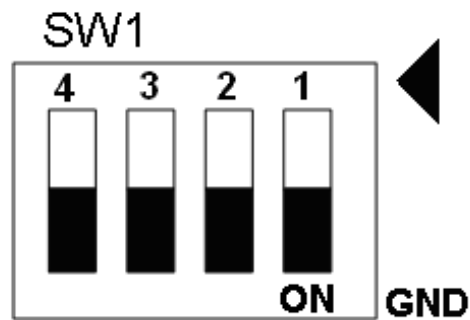

Fig. B3-9 SW1 setting for normally GND (Default setting)



Fig. B3-10 SW1 setting for user

B.4 DN-8237-YB Daughter Board

The DN-8237YB is the daughter board for Yaskawa Series Amplifier. It has 2-axis I/O signals.

B.4.1 Board Layout for DN-8237-YB

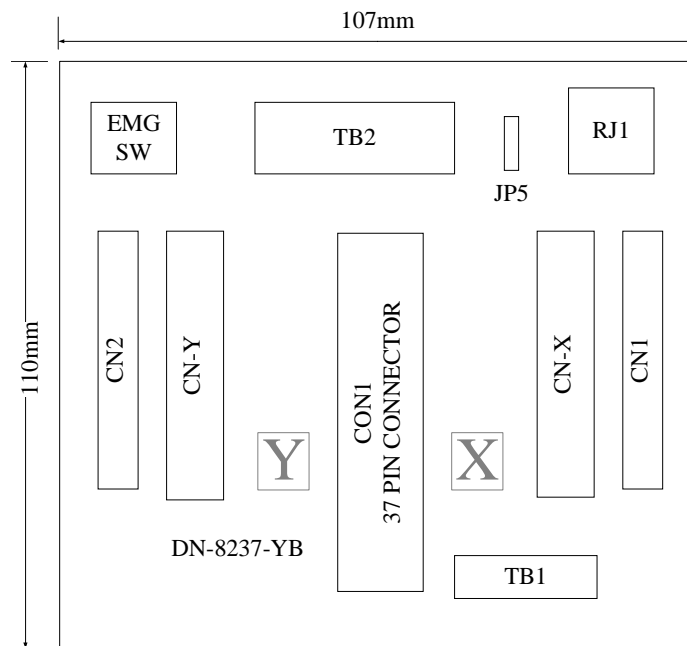

Fig. B4-1 Board layout for the DN-8237-YB

B. 4. 2 Signal Connections for DN-8237-YB

Maintaining signal connections is one of the most important factors in ensuring that your application system is sending and receiving data correctly.

■ Pin Assignment for CON1

The I/O connector on the DN-8237-YB is a 37-pin connector that enables you to connect to the PISO-PS200 or I-8092F motion card. Fig. B4-2 shows the pin assignment for the 37-pin I/O connector on the DN-8237-YB (or on the motion card), and refer to Table B4-2 for description of each motion I/O signal.

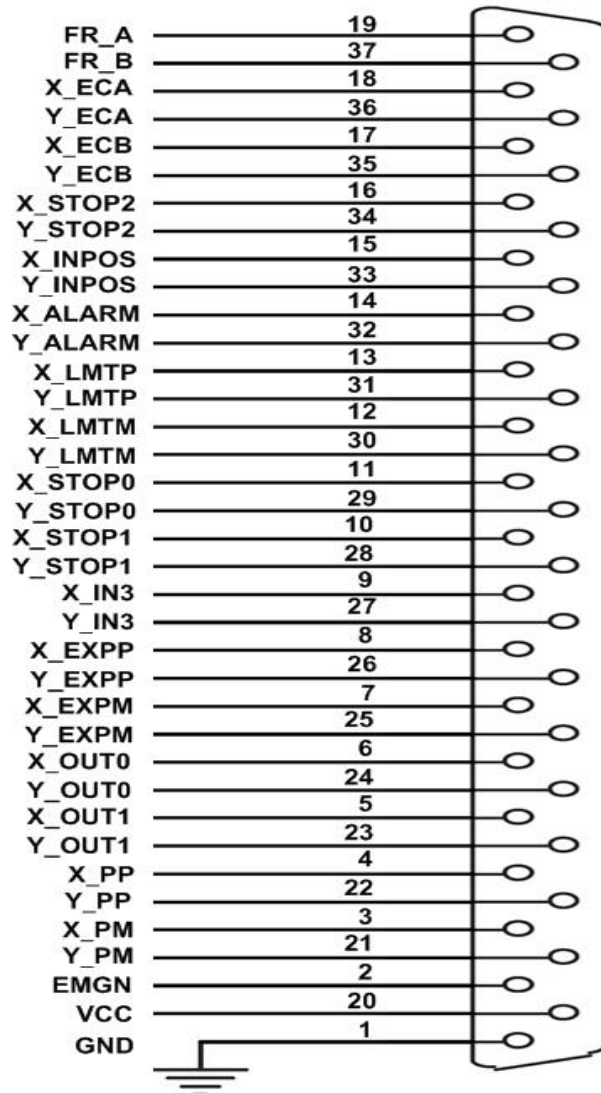

Fig. B4-2 I/O connector pin assignment for the CON1

Table B4-2 DN-8237-YB CON1 I/O connector signal description

Pin name	Pin number	Description
FR_A	19	FRnet A-phase signal
FR_B	37	FRnet B-phase signal
X_ECA	18	Encoder A-phase signal for the X axis
Y_ECA	36	Encoder A-phase signal for the Y axis
X_ECB	17	Encoder B-Phase signal for the X axis
Y_ECB	35	Encoder B-Phase signal for the Y axis
X_STOP2	16	Stop 2 signal for the X axis
Y_STOP2	34	Stop 2 signal for the Y axis
X_INPOS	15	In-position signal for the X axis
Y_INPOS	33	In-position signal for the Y axis
X_ALARM	14	Alarm signal for the X axis
Y_ALARM	32	Alarm signal for the Y axis
X_LMTP	13	Limit switch input signal (+) for the X axis
Y_LMTP	31	Limit switch input signal (+) for the Y axis
X_LMTM	12	Limit switch input signal (-) for the X axis
Y_LMTM	30	Limit switch input signal (-) for the Y axis
X_STOP0	11	Stop 0 signal for the X axis
Y_STOP0	29	Stop 0 signal for the Y axis
X_STOP1	10	Stop 1 signal for the X axis
Y_STOP1	28	Stop 1 signal for the Y axis
X_IN3	9	Input 3 signal for the X axis
Y_IN3	27	Input 3 signal for the Y axis
X_EXPP	8	EXT pulsar input signal (+) for the X axis
Y_EXPP	26	EXT pulsar input signal (+) for the Y axis
X_EXPM	7	EXT pulsar input signal (-) for the X axis
Y_EXPM	25	EXT pulsar input signal (-) for the Y axis
X_OUT0	6	Output 0 signal for the X axis
Y_OUT0	24	Output 0 signal for the Y axis
X_OUT1	5	Output 1 signal for the X axis
Y_OUT1	23	Output 1 signal for the Y axis
XPP	4	Driving pulsar signal (+) for the X axis
YPP	22	Driving pulsar signal (+) for the Y axis
XPM	3	Driving pulsar signal (+) for the X axis
YPM	21	Driving pulsar signal (+) for the Y axis
EMGN	2	Emergency stop input signal
VCC	20	Module power (+5V)
GND	1	Ground

■ TB1

The connector TB1 is 7-pin connector that enables you to connect to the signals of your motor drivers. Fig.B4-3 shows the pin assignment for the 7-pin connector on the DN-8237-YB, and the Table B4-3 shows its I/O connector signal description.

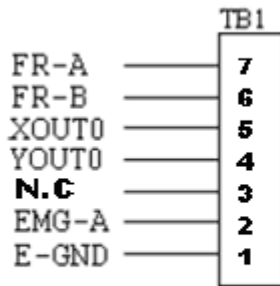

Fig. B4-3 Pin definition for TB1

Table B4-3 TB1 Signal Connection

Name	Description
FR-A	FRnet port A
FR-B	FRnet port B
XOUT0	General Output 0 for X axis
YOUT0	General Output 0 for Y axis
N.C	No Connection
EMG-A	EMG input signal for all axes
E-GND	EXT power ground

■ TB2

The connector TB2 is 5-pin connector that enables you to connect to the signals of your motor drivers. Fig.B4-4 shows the pin assignment for the 5-pin connector on the DN-8237-YB, and the Table B4-4 shows its I/O connector signal description.

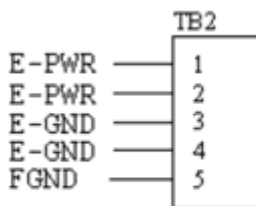

Fig. B4-4 Pin definition for TB2

Table B4-4TB2 Signal Connection

Pin name	Description
E-PWR	EXT power supply +24V
E-GND	EXT power ground
FGND	Frame ground

► **Note:** Don't reverse connect signals with E_PWR and E_GND. Serious damage to your motion card and motion controller might be happened.

■ **CN-X & CN-Y (CN1 connector for each AXIS in Driver)**

The connectors CN-X and CN-Y are 50-pin connectors that enable you to connect to the CN1 connector of Yaskawa motor drivers. Fig.B4-5 shows the pin assignment for the 50-pin connector on the DN-8468-YB, and the Table B4-5 shows its I/O connector signal description.

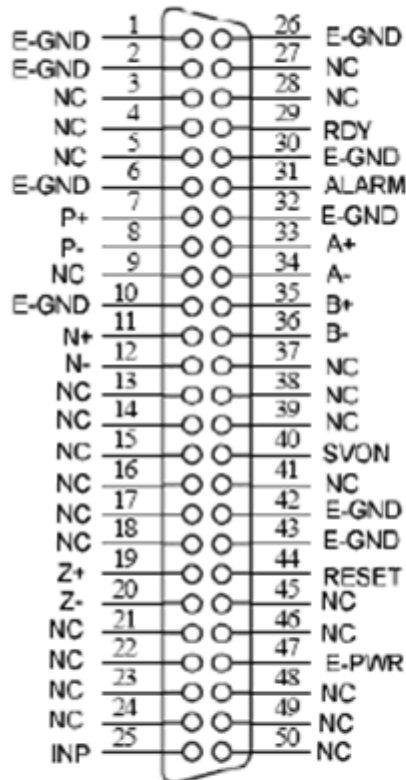

Fig. B4-5 Pin definition for CNX, CNY, CNZ, CNU

Table B4-5 CN1 Signal Connection

Name	Number	Description
A+	33	Encoder A-Phase (+)
A-	34	Encoder A-Phase (-)
B+	35	Encoder B-Phase (+)
B-	36	Encoder B-Phase (-)
Z+	19	Encoder Z-Phase (+)
Z-	20	Encoder Z-Phase (-)
P+	7	Positive Direction Pulse Output(+)
P-	8	Positive Direction Pulse Output(-)
N+	11	Negative Direction Pulse
N-	12	Negative Direction Pulse Output(-)
INP	25	Servo In Position
RDY	29	Servo Ready
SVON	40	Servo On
RESET	44	Parameter Reset
ALARM	31	Servo Alarm
E-PWR	47	EXT power +24V
E-GND	1,2,6,10, 26, 30,32, 42,43	EXT power ground
NC	3,4,5,9, 13,14,15, 16,17,18, 21,22,23, 24,27,28, 37,38,39, 41,45,46, 48,49,50,	No connection

■ CN1 & CN2 (The I/O signals of the X and Y AXIS)

The connectors CN1 and CN2 are 11-pin connectors that enable you to connect to the signals of your motor drivers. Fig.B4-6 shows the pin assignment for the 20-pin connector on the DN-8237-YB, and the Table B4-6 shows its I/O connector signal description.

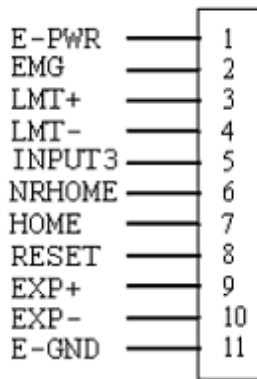

Fig.B4-6 Pin definition for CN1 & CN2

Table B4-6 CN1 & CN2 Signal Connection

Pin name	Description
E-PWR	EXT power supply +24V
EMG	EMG input signal
LMT+	Limit Switch Input Signal (+)
LMT-	Limit Switch Input Signal (-)
INPUT3	Input Signal (IN3)
NRHOME	Near Home Sensor Input Signal
HOME	Home Sensor Input Signal
RESET	Reset input signal
EXP+	EXT Positive Direction Pulse (+)
EXP-	EXT Negative Direction Pulse (-)
E-GND	EXT power ground

■ RJ1 (The I/O signals of the FRnet)

The connectors RJ1 is an 8-pin RJ45 connector that enable you to connect to the signals of FRnet. Fig.B4-7 shows the pin assignment for the 8-pin connector on the DN-8237-YB, and the Table B4-7 shows its I/O connector signal description.

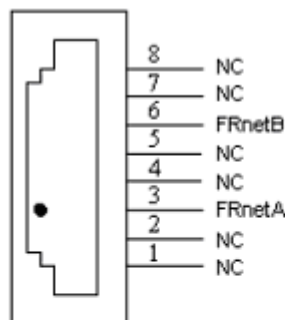

Fig.B4-7 Pin definition for RJ1

Table B4-7 RJ1

Pin name	Description
FRnetA	FRnet port A
FRnetB	FRnet port B
NC	No connection

► **Note:** Don't connect NC (not connected) signals. Connecting these signals could cause permanent damage to your motion controller.

B. 4. 3 Jumper and Switch Settings

■ JP5

Jumper 5 controls the EMG-A signal of the TB1 connector. The following diagram is shown the selection condition of the jumper 5.

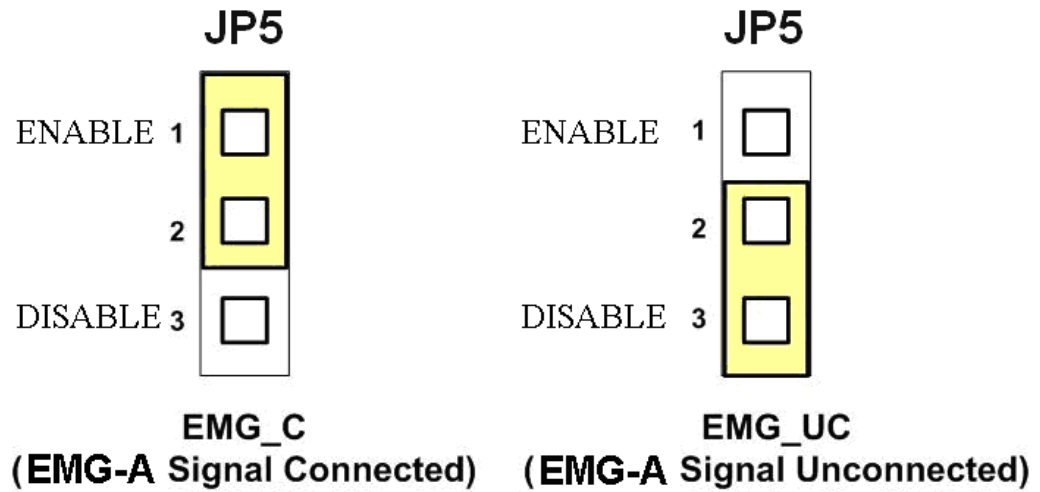

Fig. B4-8 Jumper 5 setting

■ SW 1

The emergency stop signal for each servo amplifier can be selected from SW1. The number 1 and 2 on SW1 are denoted as axis X and Y, respectively. The number 3 and 4 on SW1 are reserved for future work. Fig. B4-9 is the default setting to connect the EMG signals to GND. The EMG signals from CN1 and CN2 will not take effect. If the switch is disconnected as shown in Fig. B4-10, the emergency stop signals can be controlled from EMG signals in CN1 and CN2.

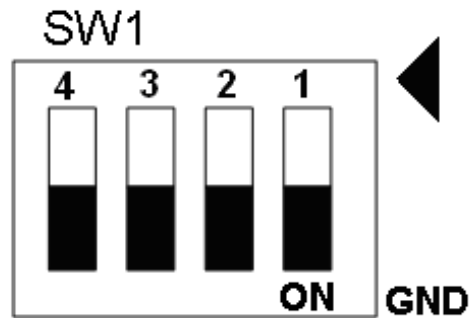

Fig. B4-9 SW1 setting for normally GND (Default setting)

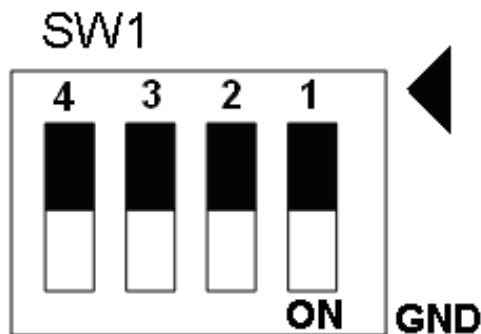

Fig. B4-10 SW1 setting for user controlled signals.