

XV303

Multifunction Expansion Board

Introduction

The XV303 is a multifunction expansion board that includes 4 Analog Output channels, 4 Digital Input channels and 4 Form A Relay Output channels. The Analog Output channels are 12-bit at +/-5 V, +/-10 V, 0 ~ +20 mA or +4 ~ +20 mA, and voltage and current outputs are jumper selectable. The XV303 also provides options for configuring power-on values for the Analog Output and Digital Output. 4 kV ESD protection and 2000 VDC intra-module isolation are also provided to enhance noise immunity capabilities in industrial environments.

System Specifications

Communication	
Interface	RS-232/TTL
Format	N, 8, 1
Baud Rate	115200 bps
Protocol	Modbus/RTU
Isolation	
Intra-module Isolation, Field-to-Logic	2000 VDC
EMS Protection	
ESD (IEC 61000-4-2)	±4 kV Contact for each Terminal
	±8 kV Air For Random Terminal
Power	
Power from Terminal Block	5 VDC
Consumption	2.9 W Max.
Mechanical	
Dimensions (L x W x H)	82 mm x 59 mm x 13 mm
Environment	
Operating Temperature	-25 ~ +75°C
Storage Temperature	-30 ~ +80°C
Humidity	10 ~ 90% RH, Non-condensing

Features

- Multifunction (4 AO, 4 DI, 4 Relay)
- Individual Channel Configuration for Analog Output
- Jumper Selectable Voltage or Current Output
- Open Wire Detection for Current Output
- Configurable Power-on Value Settings
- 70 VDC Overvoltage Protection for Digital Input



I/O Specifications

Analog Output		
Channels	4	
Type	0 V ~ +5 V, ±5 V, 0 V ~ +10 V, ±10 V, 0 mA ~ +20 mA, +4 mA ~ +20 mA (Jumper Selectable)	
Resolution	12-bit	
Accuracy	±0.1%	
Voltage Output Capability	10 V @ 20 mA	
Current Load Resistance	500 Ω	
Power-on Value	Yes	
Individual Channel Configuration	Yes	
Digital Input/Counter		
Input Channels	4	
Type	Dry Contact	-
	Wet Contact	Sink/Source
ON Voltage Level	Dry Contact	-
	Wet Contact	+3.5 ~ +50 VDC
OFF Voltage Level	Dry Contact	-
	Wet Contact	+1 VDC Max.
Input Impedance	10 KΩ, 0.5 W	
Counters	Channels	4
	Max. Count	32-bit (0 ~ 4, 294, 967, 285)
	Max. Input Frequency	50 Hz
	Min. Pulse Width	10 ms
Overvoltage Protection	70 VDC	
Relay Output		
Channels	4	
Type	Power Relay	
Form A Relay	Contact Rating	6 A @ 35 VDC 6 A @ 240 VAC
	Min. Contact Load	100 mA @ ≥ 12 V
	Contact Material	Silver Cadmium Alloy
	Operate Time	5 ms (typical)
	Release Time	1 ms (typical)
	Mechanical Endurance	30 x 10 ⁶ ops.
Electrical Endurance	1 x 10 ⁵ ops.	
Power-on Value	Yes	

Pin Assignments

DI.COM	DI3	DI2	DI1	DI0	RL3 COM	RL3 NO	RL2 COM	RL2 NO	RL1 COM	RL1 NO	RL0 COM	RL0 NO	AGND	AOUT3	AOUT2	AOUT1	AOUT0
XV303																	

Internal I/O Structure

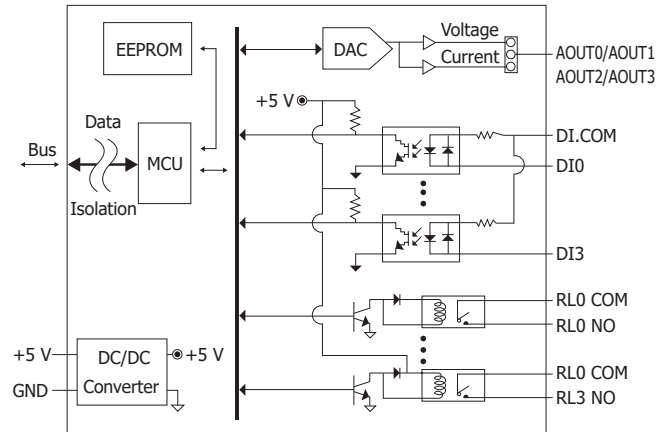

Wire Connections

Voltage Output		
		Jumper Vout
Current Output		
		Jumper IOUt
Digital Input/Counter	Readback as 1	Readback as 0
	+3.5 ~ +50 VDC	+1 VDC Max.
Wet Contact (Sink)		
Wet Contact (Source)		
Power Relay	Readback as 1	Readback as 0
Relay Output		

Ordering Information

XV303 CR	Multifunction Expansion Board
----------	-------------------------------