



J1939 Series Products



J1939/Modbus RTU Slave Gateway



GW-7228

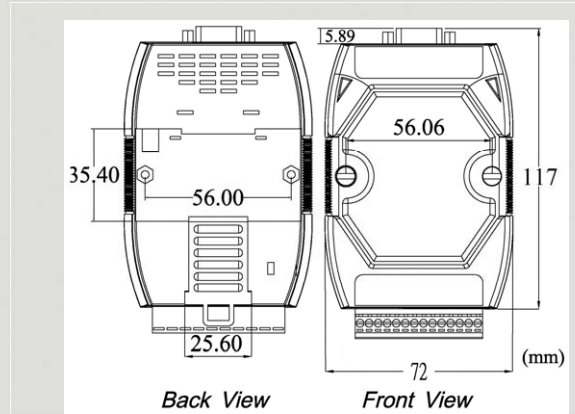

Dimensions

The GW-7228 is a solution that provides a protocol conversion between J1939 and Modbus RTU. For J1939 network, the GW-7228 supports PDU1, PDU2, broadcast and destination specific type of J1939 messages. From the view of Modbus RTU network, the GW-7228 is a Modbus RTU slave to reply the request from Modbus RTU master. We provide Utility software for users to configure the parameters of J1939 / Modbus RTU of the GW-7228. The application fields can be Diesel power-train applications, In-Vehicle networks for trucks and buses, etc.

Features

- Provide PWR / J1939 / MODBUS indication LED
- Built-in jumper to select 120 ohm terminal resistor
- Watchdog inside
- Transmission and reception of all types of J1939 messages, including PDU1, PDU2, broadcast and destination specific
- J1939 Transport Protocol for transmission and reception of large messages (9 - 1785 bytes)
- Support BAM of Connection Management Message
- Network addresses management
- Support RS-232, RS-485 and RS-422 interfaces
- Support Modbus RTU slave protocol
- Configurable for Modbus Network ID(1~250)
- Configurable baud rates of 2400, 4800, 9600, 19200, 38400, 57600, 115200 bps
- Configurable for none, odd, or even parity and 1 or 2 stop bits
- Support Function Code 03 / 04 / 06 / 16 of Modbus functions for reading and writing J1939 Messages

Utility Features

- Provide Modbus network configuration interface
- Provide J1939 network configuration interface – Network Address / Device Name....
- Provide J1939 Input / Output configuration interface

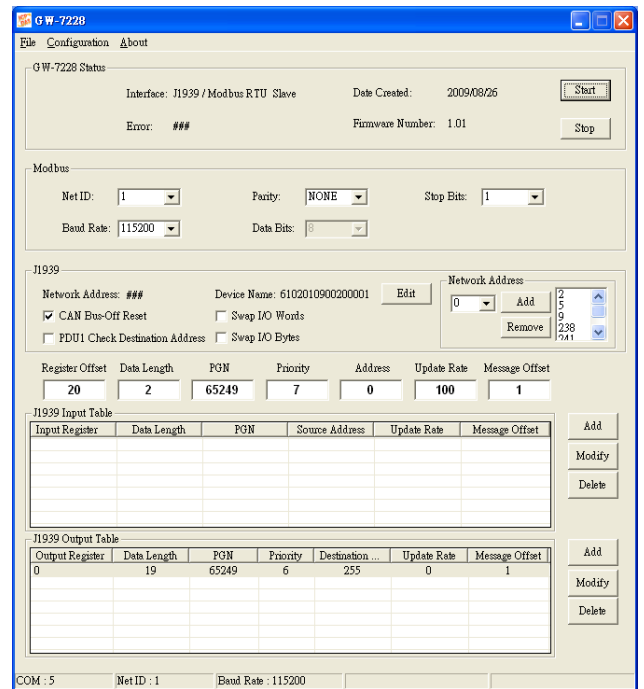

Wire Assignments

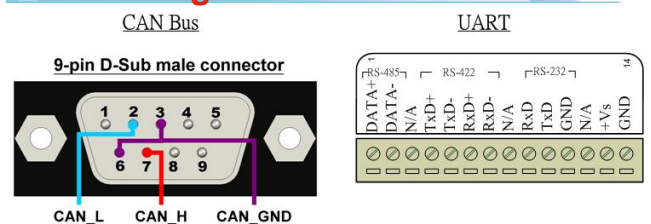

Hardware Specifications

Hardware	
J1939 Port Channels	1
CAN Interface	
Controller	Microprocessor inside with 96 MHz
Transceiver	NXP 82C250
Connector	9-pin D-sub connector
Baud Rate (bps)	250k
Isolation	3000 V _{DC} power protection on CAN side, 2500Vrms photo-couple isolation on CAN bus
Terminal Resistor	Selectable 120Ω terminal resistor by jumper
Specification	ISO-11898-2, CAN 2.0A and CAN 2.0B
Pin Assignment	C.I.A. DS-102 (CAN_H=7, CAN_L=2)
UART Interface	
Connector	14-pin screw terminal connector
COM1	RS-232(TXD, RXD, GND) / RS-422(Tx+, Tx-, Rx+, Rx-) / RS-485(D+, D-)
Baud Rate (bps)	2400, 4800, 9600, 19200, 38400, 57600, 115200
LED	
Round LED	PWR / J1939 / MODBUS
Power	
Power supply	+10 ~ +30 V _{DC}
Power Consumption	1.5 W
Dip Switch	Init (Firmware Update) / Normal (Firmware Operation)
Mechanism	
Installation	DIN-Rail
Dimensions	108mm x 72mm x 35mm (H x W x D)
Environment	
Operating Temp.	-25 ~ 75 °C
Storage Temp.	-30 ~ 80 °C
Humidity	10 ~ 90% RH, non-condensing

Application

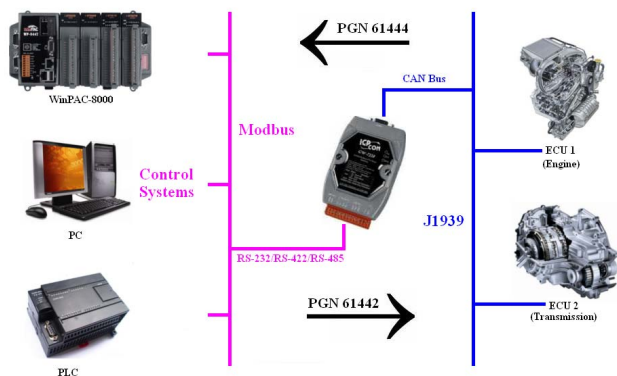

Block Diagram

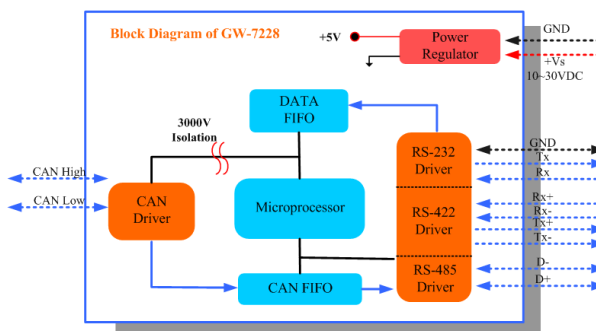

Ordering Information

GW-7228 CR

J1939/Modbus RTU Slave Gateway (RoHS)