



I-7033(D)

M-7033(D)

3-ch RTD Input Module

Features

- 3 RTD Inputs
- Lead Resistance Elimination for 3/4-wire Connections
- Open Wire Detection
- Built-in Dual Watchdog



Introduction

The I-7033 is a 3-channel RTD Input module that is used for measuring temperatures via an RTD sensor and supports Pt100, Ni120, and Pt1000 type sensors. The module allows 2/3/4-wire RTD connections and features open wire detection. In addition, the I-7033 also includes 3000 VDC intra-module isolation, and supports lead resistance elimination for 3/4-wire connections.

System Specifications

Model	I-7033 M-7033	I-7033D M-7033D
CPU Module		
Watchdog Timer	Module, Communication (Programmable)	
Display		
Type	7033D: 5-Digit 7 Segment LED Display	
Isolation		
Intra-module Isolation	3000 VDC	
EMS Protection		
EFT (IEC 61000-4-4)	±4 kV for Power Line	
ESD (IEC 61000-4-2)	±2 kV Contact for Each Terminal	
Surge (IEC 61000-4-5)	±0.5 kV for Power Line	
LED Indicators		
Status	1 x Power and Communication	
COM Ports		
Ports	1 x RS-485	
Baud Rate	1200 ~ 115200 bps	
Data Format	(N, 8, 1), (N, 8, 2), (E, 8, 1), (O, 8, 1)	
Protocol	I-7000: DCON	
	M-7000: Modbus RTU, DCON	
Power		
Reverse Polarity Protection	Yes	
Input Range	+10 ~ +30 VDC	
Consumption	1.0 W	1.6 W
Mechanical		
Dimensions (mm)	72 x 123 x 35 (W x L x H)	
Installation	DIN-Rail Mounting	
Environment		
Operating Temperature	-25 ~ +75°C	
Storage Temperature	-40 ~ +85°C	
Humidity	10 ~ 95% RH, Non-condensing	

I/O Specifications

Model	I-7033 M-7033	I-7033D M-7033D
Analog Input		
Channels	3	
Type	RTD	
Sensor Type	Pt100, Pt1000, Ni120	
Resistance Measurement	3.2 kΩ Max.	
Resolution	16-bit	
Accuracy	±0.1% of FSR	
Sampling Rate	15 Hz	
Overvoltage Protection	±25 VDC	
Open Wire Detection	Yes	
3/4-wire RTD Lead Resistance Elimination	Yes	

RTD Type Settings (TT)

Type Code	RTD Type	Temperature Range
20	Platinum 100, α= 0.00385	-100 to +100°C
21	Platinum 100, α= 0.00385	0 to +100°C
22	Platinum 100, α= 0.00385	0 to +200°C
23	Platinum 100, α= 0.00385	0 to +600°C
24	Platinum 100, α= 0.003916	-100 to +100°C
25	Platinum 100, α= 0.003916	0 to +100°C
26	Platinum 100, α= 0.003916	0 to +200°C
27	Platinum 100, α= 0.003916	0 to +600°C
28	Nickel 120	-80 to +100°C
29	Nickel 120	0 to +100°C
2A	Platinum 1000, α= 0.00385	-200 to +600°C
2E	Platinum 100, α= 0.00385	-200 to +200°C
2F	Platinum 100, α= 0.003916	-200 to +200°C
80	Platinum 100, α= 0.00385	-200 to +600°C
81	Platinum 100, α= 0.003916	-200 to +600°C
82	Cu 50 at 0°C	-50 to +150°C

Internal I/O Structure

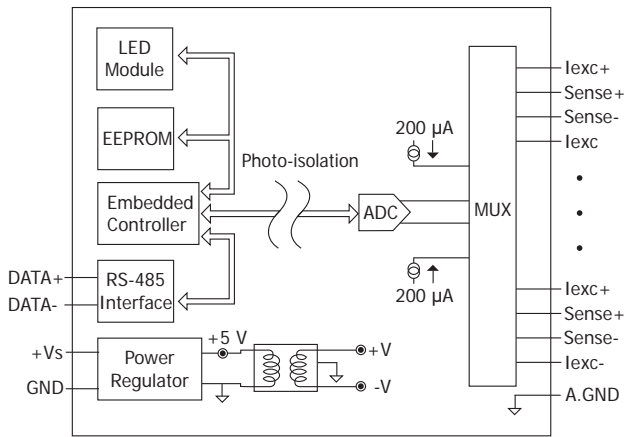

Pin Assignments

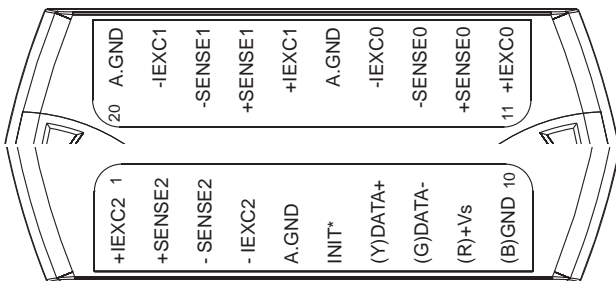



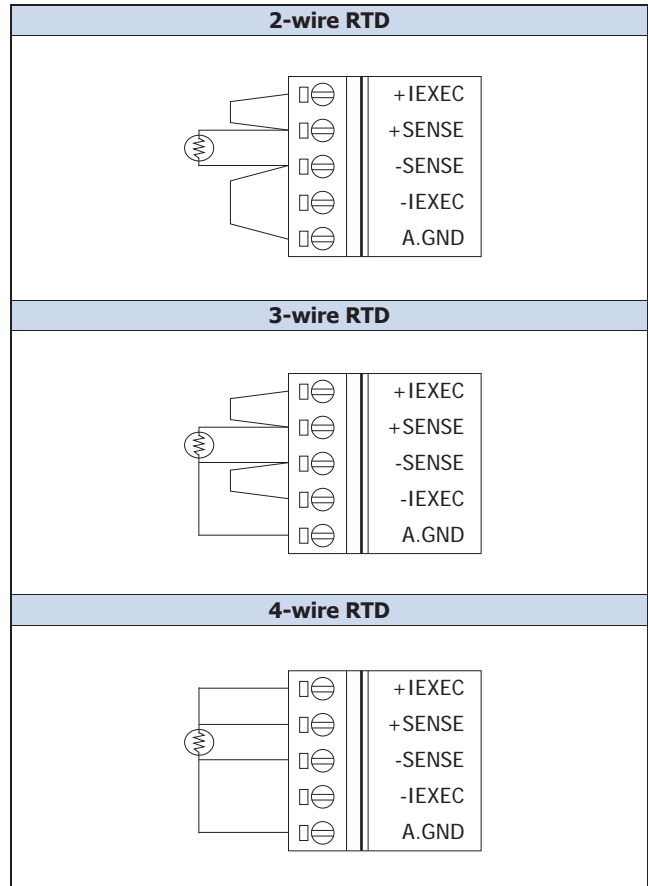



Wire Connections



Ordering Information

I-7033 CR	3-ch RTD Input Module using DCON Protocol (Blue Cover) (RoHS)
I-7033D CR	3-ch RTD Input Module with LED Display using DCON Protocol (Blue Cover) (RoHS)
I-7033D-G CR	3-ch RTD Input Module with LED Display using DCON Protocol (Gray Cover) (RoHS)
M-7033-G CR	3-ch RTD Input Module using DCON and Modbus Protocols (Gray Cover) (RoHS)
M-7033D-G CR	3-ch RTD Input Module with LED Display, using DCON and Modbus Protocols (Gray Cover) (RoHS)

Accessories

tM-7520U CR	 Tiny Isolated RS-232 to RS-485 Converter (RoHS)
tM-7561 CR	 Tiny USB to Isolated RS-485 Converter with CA-USB18 Cable (RoHS)
tM-SG4 CR	 RS-485 Pull-high/Pull-low and Termination Resistor Module (RoHS)
I-7514U CR	 Isolated 4-channel RS-485 Repeater/Hub/Splitter (Gray Cover) (RoHS)
SG-770 CR	 7/14 channel Surge Protector (RoHS)
SG-3000 Series	 Signal Conditioning Modules for Thermocouple, RTD, DC Voltage, DC Current and Power Input Transformers