



WF-2042

Quick Start

Mar. 2014 Version 1.0

「 WF-2042 」 Package Checklist

The package includes the following items:

- One WF-2042 module
- One Quick Start
- One software utility CD
- One screw driver
- One RS-232 cable (CA-0910)
- One Antenna 2.4GHz - 5 dBi (ANT-124-05)



Note:

If any of these items are missed or damaged, contact the local distributors for more information. Save the shipping materials and cartons in case you want to ship in the future.

● Appearance and pin assignments

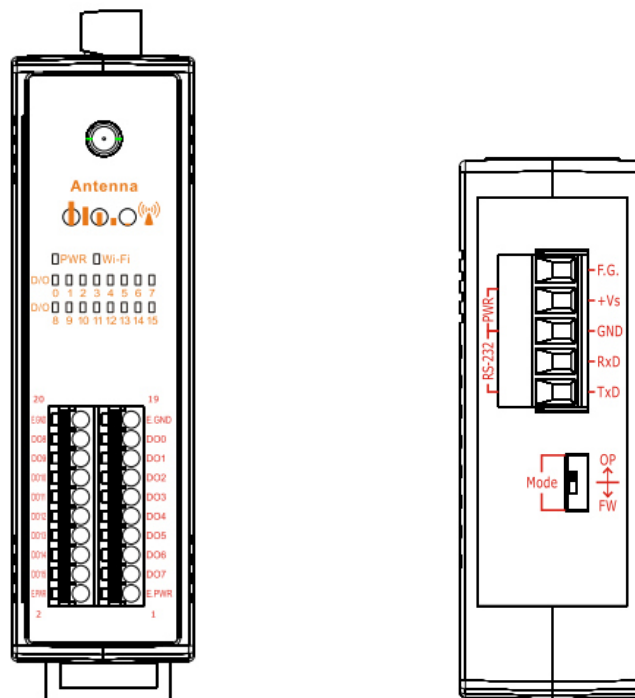

Figure 1: Appearance of the WF-2042



Pin Assignment Name		Terminal No.	Pin Assignment Name	
EXT.GND	20		19	EXT.GND
DO8	18		17	DO0
DO9	16		15	DO1
DO10	14		13	DO2
DO11	12		11	DO3
DO12	10		9	DO4
DO13	8		7	DO5
DO14	6		5	DO6
DO15	4		3	DO7
EXT.PWR	2		1	EXT.PWR

Figure 2: I/O Connector of WF-2042

Table 1: Power/Signal Connector

Power/Signal connector	
Pin Assignment	Description
F.G	Frame Ground
+Vs	+10 ~ +30 VDC
GND	Power / RS-232 GND
RxD	RS-232 RxD
TxD	RS-232 TxD

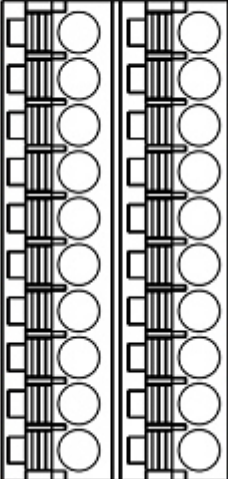
Table 2: Operating Mode Selector Switch

Operating Mode Selector Switch		
Mode	Jumper Position	Description
FW		Firmware update mode
OP		Firmware operation mode

● Hardware Connection

Power and Serial port connection

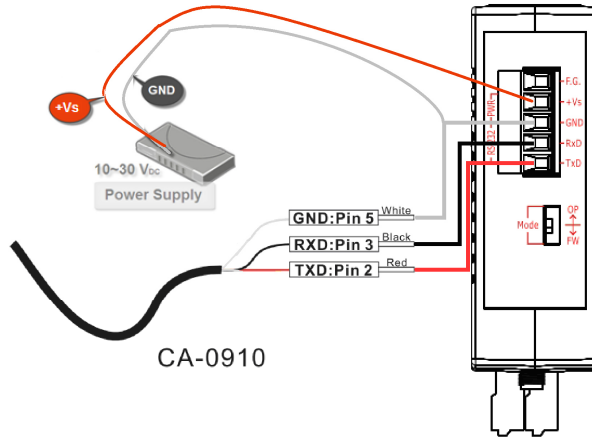

Figure 4: Power and Serial port wire connection

I/O connection

Output Type	ON State LED ON	OFF State LED OFF
	Relay ON	Relay OFF
Drive Relay		
Resistance Load		

Figure 5: DO wire connection

● Installation

Before use, associated hardware configuration, the steps described as follows :

Step 1: Checking the WF-2000 series firmware operation mode

It needs to set the DIP switch to the "OP" position (operation mode), as resetting the power, WF-2000 series will be in the operation mode.

Step 2: Serial port connection

WF-2000 series supports RS-232 serial communication. The circuit configuration is as shown in Figure 4.

If you do not need to configure parameters, this step can be omitted.

Step 3: Power connection

Connect the power supply to WF-2000 series' power terminator, as shown in Figure 4.

WF-2000 series connection setting

WF-2000 Series Wireless Network Configuration

The screenshot shows the 'NetworkConfig' application window with three main sections: Network, Wi-Fi, and General.

- Network:**
 - Net ID: 1
 - DHCP Enable
 - IP Address: 192.168.255.1
 - Subnet Mask: 255.255.255.0
 - Gateway: 192.168.255.254
 - MAC Address: 00-1D-C9-80-0B-47
- Wi-Fi:**
 - Wi-Fi Modes: Ad-Hoc
 - SSID Auto Search (Search button)
 - SSID: WF-2042
 - Encryption: NONE
 - Wireless Key: (empty field)
 - Wireless CH: 2
- General:**
 - F/W Version: 1.0
 - Date Created: 2014/1/8
 - Auto Disconnect
 - Comm. Net ID: 1
 - RS-232: (dropdown)
 - COM3: (dropdown)
 - Buttons: Write, Read

Figure 6: Wi-Fi Configuration

- 01 、 Net ID : The Unit Identifier in Modbus TCP/IP application data unit. This case is set as "1".
- 02 、 IP Address: WF-2000 series' IP address. Here set to "192.168.255.1".
- 03 、 Subnet Mask : Net Mask settings. Here set to "255. 255. 255.0".
- 04 、 Gateway : Gateway settings. Here set to "192.168.255.254".
- 05 、 Wi-Fi Mode : Wireless network connection mode settings. Here set to "Ad-Hoc" mode. (If select the "AP" mode, wireless AP devices is needed.)
- 06 、 SSID : Service set identifier. Here set to "WF-2042".
- 07 、 Encryption : Encryption mode settings. Here set "NONE" (without encryption).

- 08 \ Wireless Key : Wireless encryption Key. Here does not have the setting.
- 09 \ Wireless CH : Wi-Fi connection channel settings. Here set to "2".
- 10 \ Upload parameters : After completing the settings above, select the "RS-232" interface, communication "Net ID" and "COM Num". Press "Write Parameter" button to upload the parameters.

PC Wireless Network Configuration and Connection

01 \ TCP/IP Setting :

- a. Entry the **IP address** as "192.168.255.x", where "x" is a number between 1 and 254 **except 1**, **Subnet mask** as "255.255.255. 0". Finally, press "OK" button.

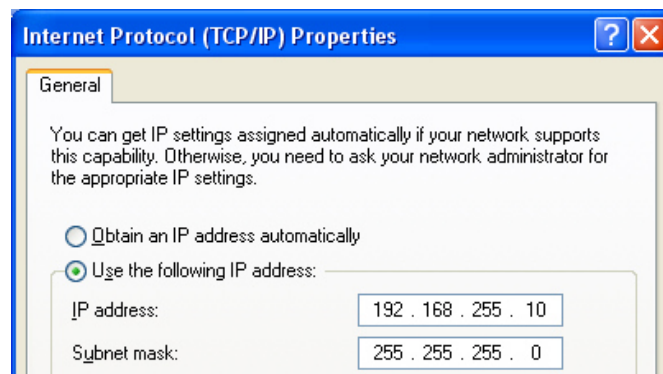

Figure 7: IP address configuration interface

02 \ Wireless network connection :

- a. View available wireless networks and you can see the "WF-2042" wireless network in the list.
- b. Select the "WF-2042" and press the "Connect" button.
- c. After waiting for a while, there will appear connection success screen.

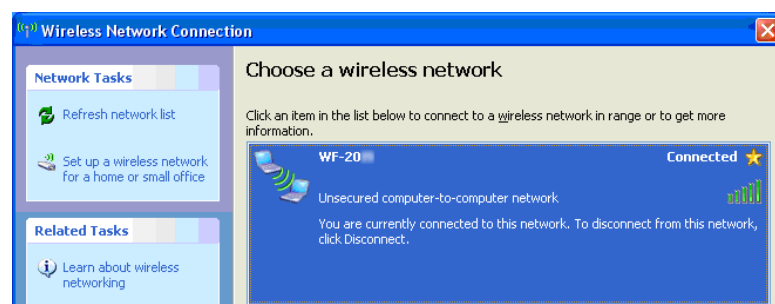

Figure8: Connection successful interface

Access I/O data

01、Connection with Modbus TCP utility

- Open Modbus TCP utility and key in the IP address as "192.168.255.1", Port as "502". Finally, click the "Connect" button.
- If the network settings are correct, this will immediately establish a connection.
- Use the function code "0x01", and set the Reference Number as "0x00", Bit Count as "0x10" to get the 16 CHs DO value.

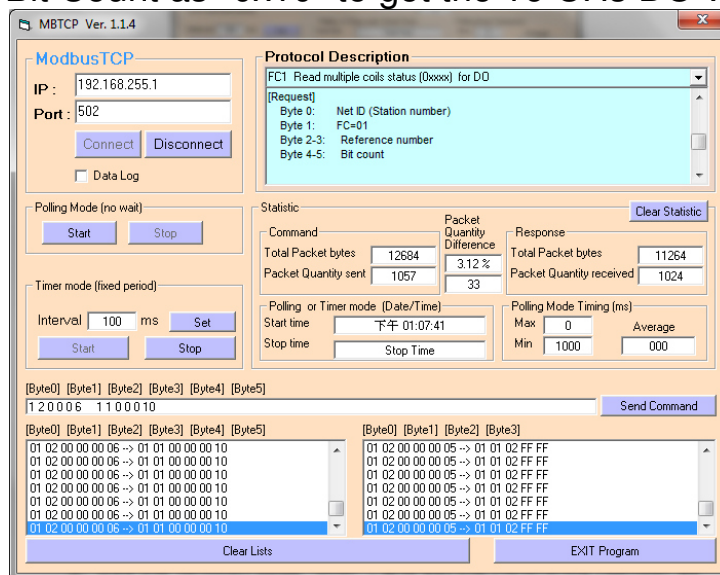

Figure 9: Read multiple coils status for DO

- Use the function code "0x0F", and set the Reference Number as "0x00", Bit Count as "0x10", Byte Count as "0x02" to force multiple coils for 16 CHs DO.

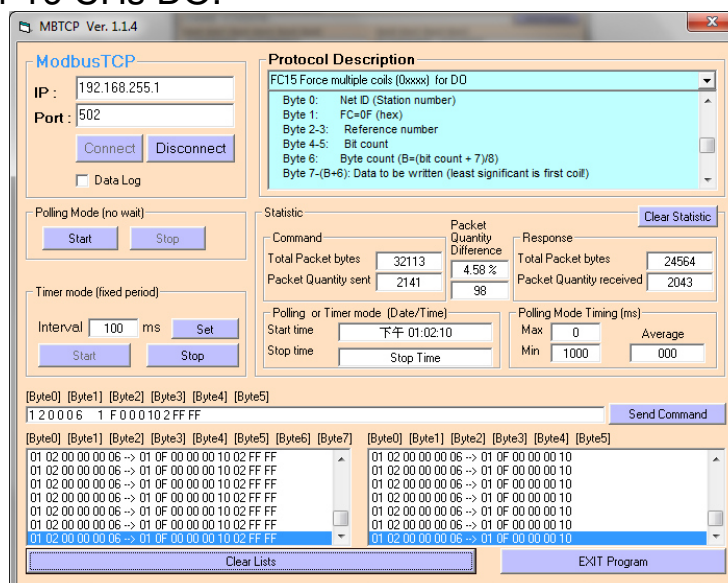

Figure 10: Force multiple coils for DO

WF-2042 I/O Address Mapping

Table 1: (0xxxx) DO address

Begin Address	Points	Descriptions	Range	Access Type
0 (0x00)	0~15	Digital Output	0=OFF, 1=ON	R/W

Table 2: (4xxxx) AO address

Begin Address	Points	Descriptions	Range	Access Type
247 (0xF7)	0	Reset System	1= Reset System 247= Restore to Factory Default Settings	W

Troubleshooting

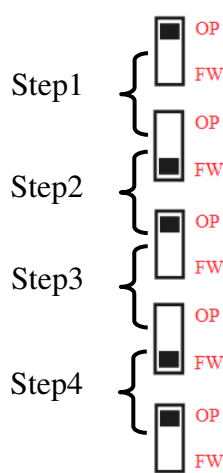
Item	Problem Description	Solution
1	Power Failure (PWR LED Off)	1. Please return to the ICP DAS for inspection and repair
2	WLAN connection can not be established	<ol style="list-style-type: none"> 1. Make sure that the service set identifier device (SSID) settings are the same. 2. Make sure Wi-Fi transmission Channel settings are the same. 3. Make sure encryption is set, encryption keys are the same way 4. Make sure antenna is connected 5. Please confirm whether there are barriers on the scene. That could result in poor signal quality.
3	TCP connection can not be established	<ol style="list-style-type: none"> 1. Make sure WLAN connection is established successfully 2. Make sure the network configuration is good (TCP / IP Port, Local IP, Net Mask)
4	<p>How to restore factory default</p>  <p>The diagram illustrates four steps for restoring factory defaults using a dip-switch. Each step shows a switch being moved from one position to another. The positions are labeled 'OP' (Open) and 'FW' (Factory Default). Step 1: Switch is moved from OP to FW. Step 2: Switch is moved from FW to OP. Step 3: Switch is moved from OP to FW. Step 4: Switch is moved from FW to OP.</p>	<ol style="list-style-type: none"> 1. Power on the WF-2000 series I/O module 2. Change the Dip-Switch position of the WF-2000 series and to complete the following steps in 5 seconds. <ul style="list-style-type: none"> Step1. From "OP" to "FW" position. Step2. From "FW" to "OP" position. Step3. From "OP" to "FW" position. Step4. From "FW" to "OP" position. 3. When the correct implementation of the above steps, the Signal Strength LEDs and PWR/Wi-Fi LEDS of the WF-2000 series should be turn on, and that should be turn off after 500 ms later. 4. Reset the power the WF-2000 series would back to factory defaults.

● Technical Support

If you have problems about using the WF-2000 series I/O module, please contact ICP DAS Product Support.

Email: service@icpdas.com