







iCAM-MR6322 Quick Start

v1.2, 01/2021

Packing List

IP Camera iCAM-MR6322 includes following items:

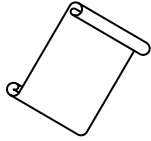
| | | |
|--|--|--|
|  |  (inserted in) |  |
| iCAM-MR6322 x 1 | 4 GB Micro SD Card x 1 | Alignment Sticker x 1 |
|  | |  |
| Screws and Anchor Set x 3, Hex Key (Allen Key) x 1 | | Quick Start x 1 |

Technical Resources

How to search for drivers, manuals and spec information on ICP DAS website.

- For Mobile Web



Technical Support
service@icpdas.com
<https://www.icpdas.com>

- For Desktop Web



1 Part Description & Dimensions

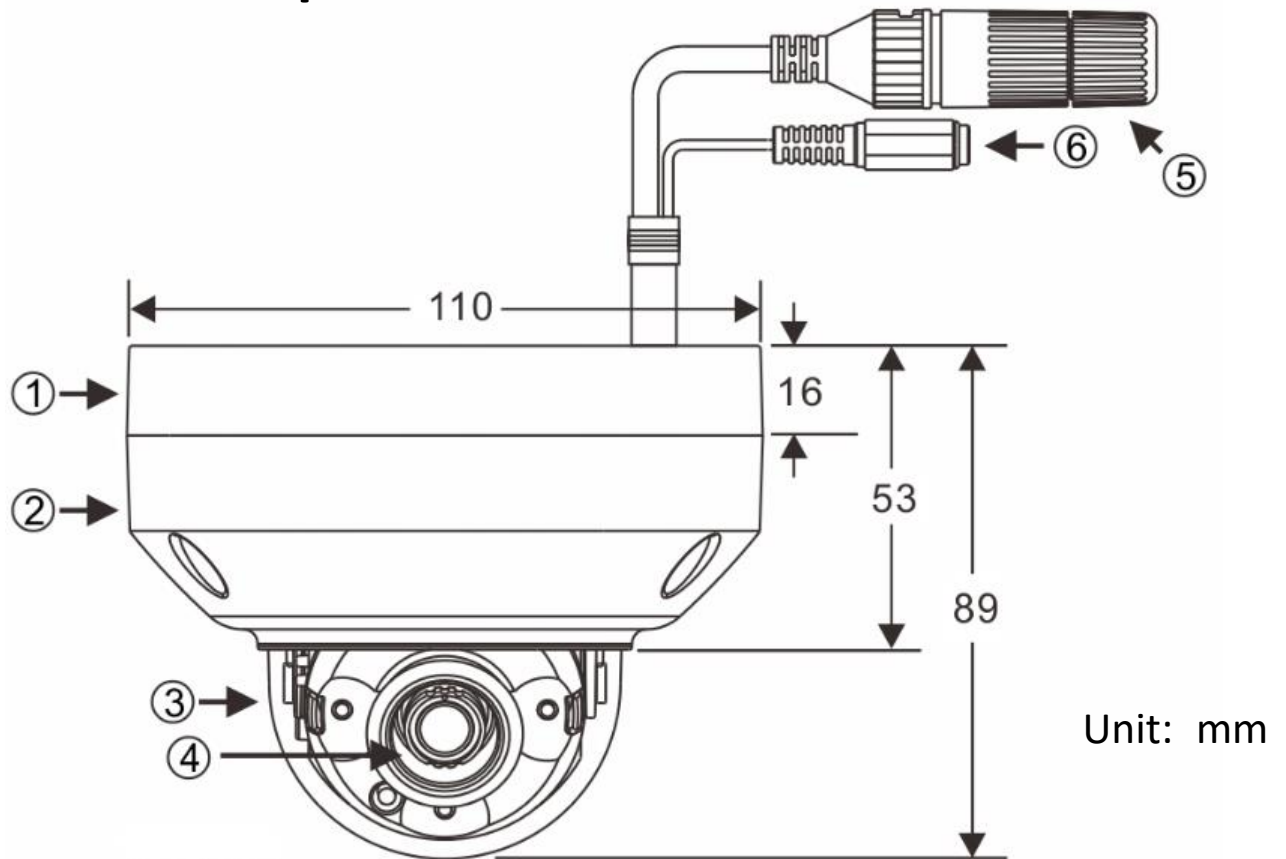

- ① Bottom bracket
- ② Upper cover
- ③ Transparent cover
- ④ Lens
- ⑤ RJ-45 Ethernet connector (support PoE)
- ⑥ Power jack (DC12V \pm 10%)
- ⑦ Micro SD card slot
- ⑧ Factory default button

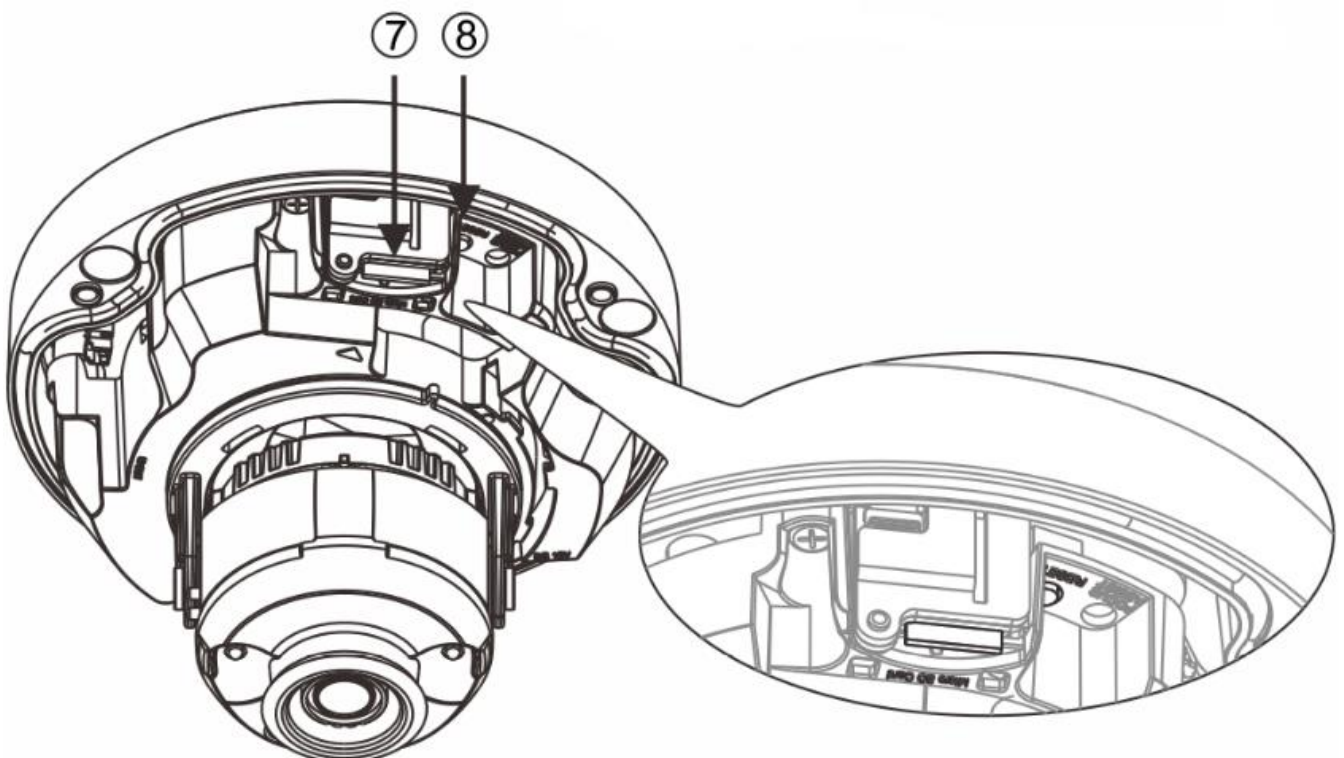

2 Hardware Installation

- 1) Retrieve the camera and remove the bottom bracket from the upper cover with a hex key (PIC.1). Use the included screws through the holes marked as "a", and fix the camera in the desired location (PIC.2&3)

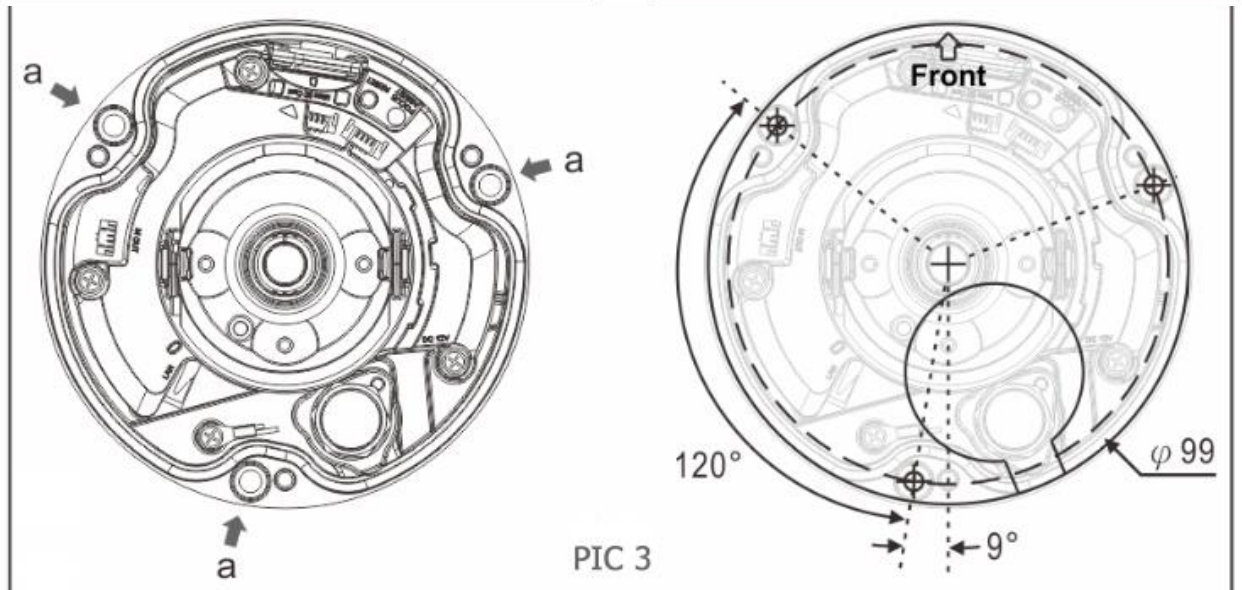
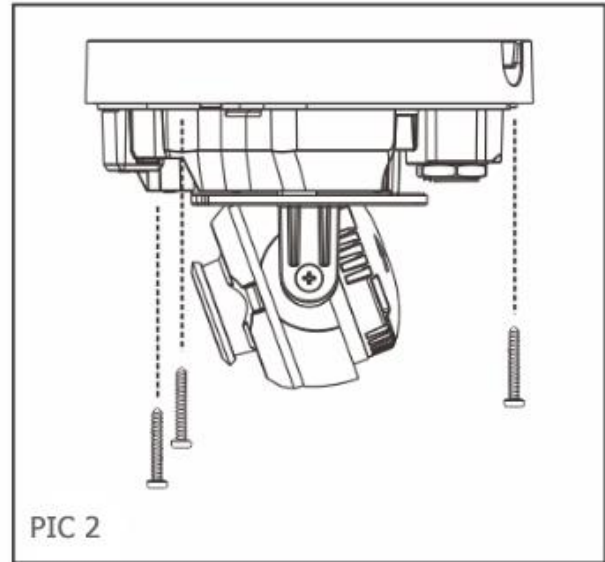
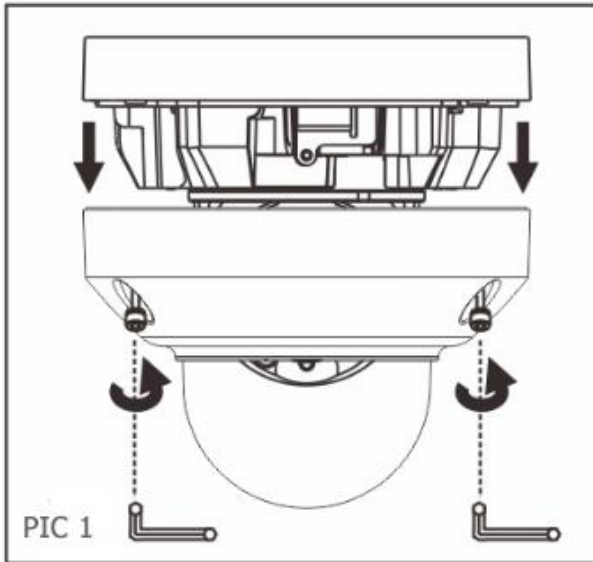

- 2) Attach the Ethernet and power cables to the RJ-45 connector and the DC-in connector, respectively (PIC.4).

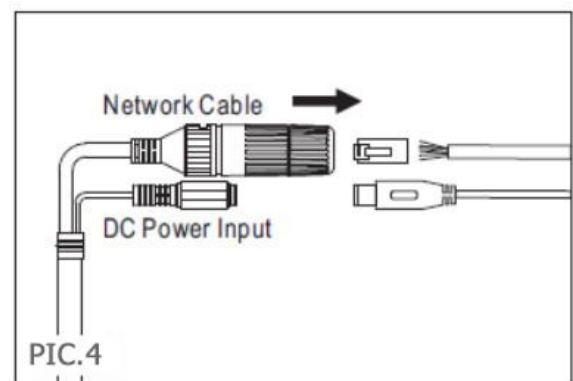

- *Connect the RJ-45 Ethernet cable with a waterproof connector*

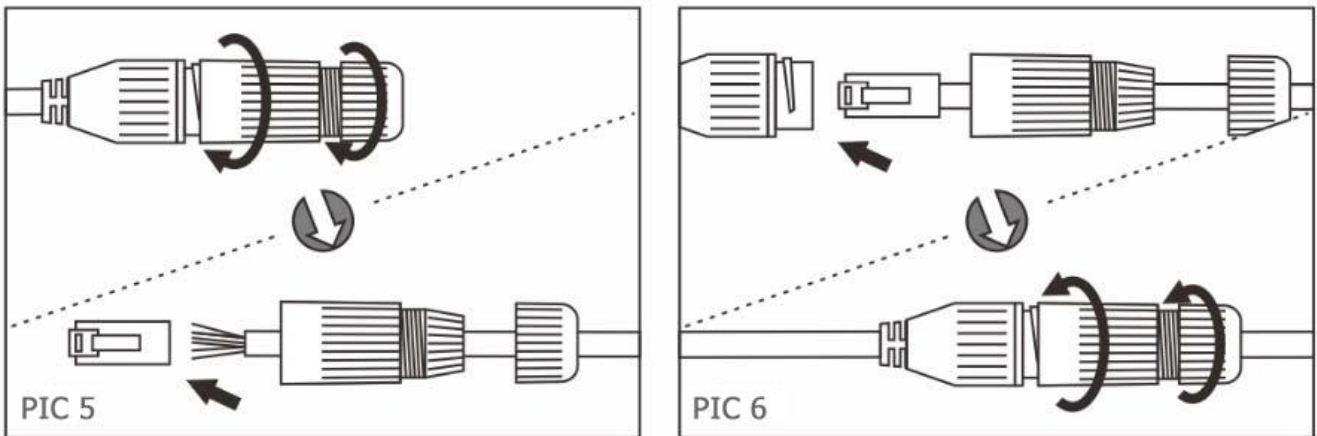

First, remove the waterproof connector and unscrew the waterproof nut. Insert the Ethernet cable and connect to the RJ-45 connector with proper tools (PIC.5). Then, tighten the waterproof connector and nut before the RJ-45 connector is connected to the camera (PIC.6).

- 3) Adjust the pan, tilt, and azimuth of the camera to the desired location (PIC.7). Secure the upper cover to the bottom bracket with a hex key (PIC.8).

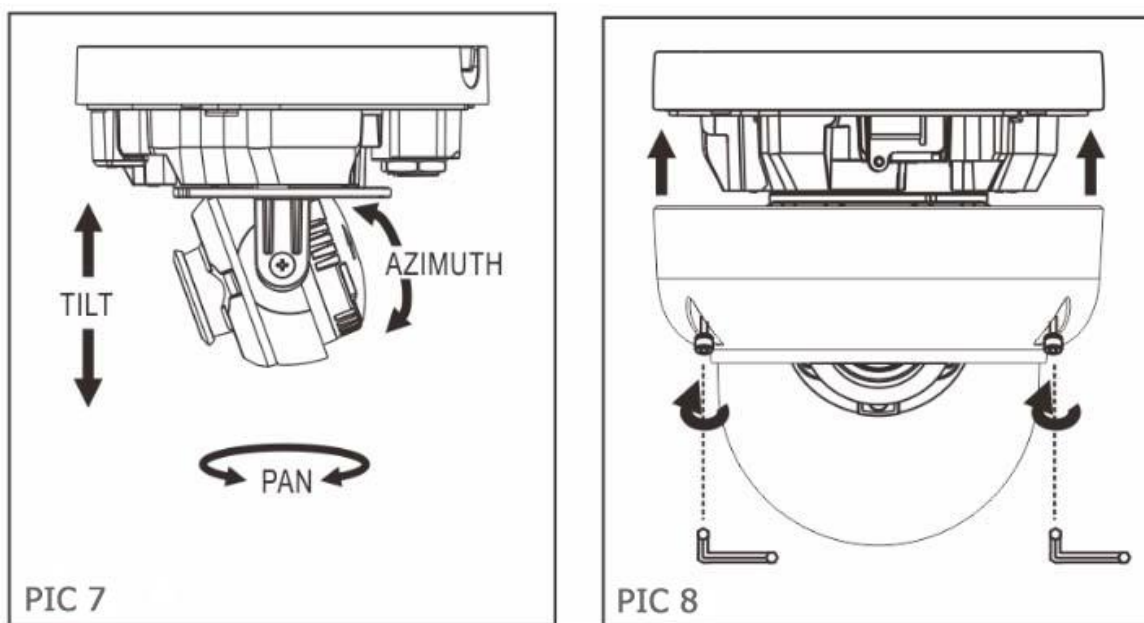

3 System Architectures

For connecting IP Camera to your network, please choose one of the following system architectures:

(1). Use DC12V power adaptor and network switch connected to a network.

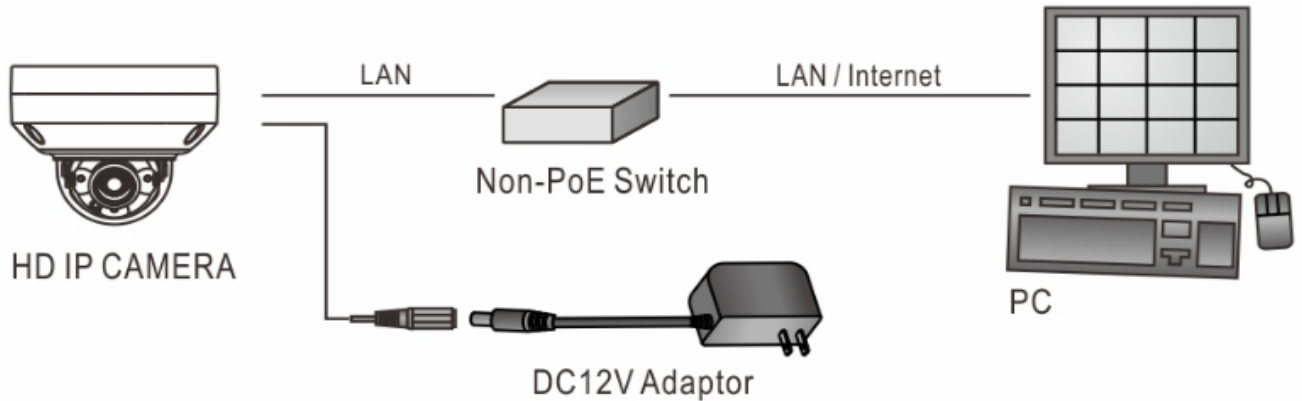

(2). Connected to the network using a PoE switch.

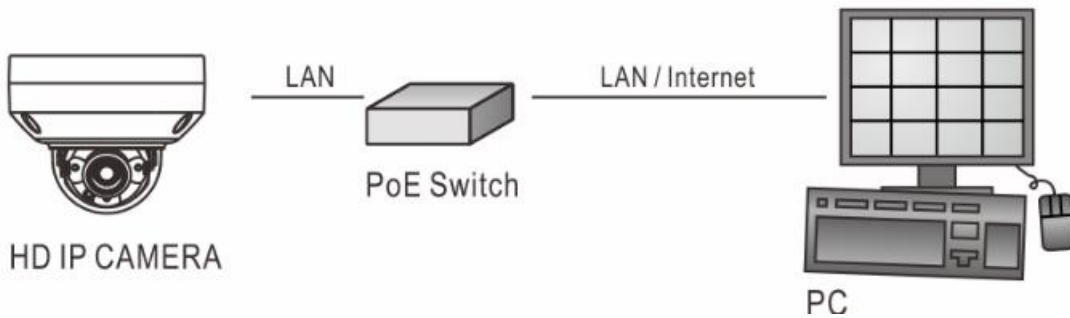

(3). Use PoE power injector and network switch connected to the network.

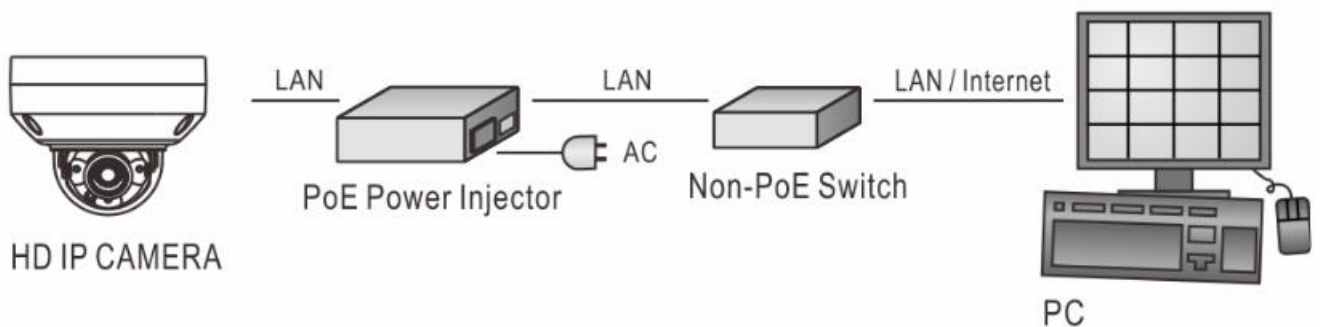

4 Reset to Factory Defaults

Reset the hardware to factory defaults, please follow these steps:

1. Press and hold “Factory default button” for more than **10** seconds until the Len LED flashes once, then release the button.
2. Wait for **40** seconds, then the network LED light will turn off, and go back on again.
3. The camera is now restored to factory defaults, and will auto reboot.
4. Search for the device IP using the IPScan software. Remember to check the items “**ONVIF**” & “**ONVIF Deep Scan**”.
5. Use a web browser to open this device IP.
6. Enter default username “**admin**” and password “**pass**” to operate.

Note: Reset to the factory defaults will restore to the default IP address: **192.168.0.200**

5 Before Accessing IP Cameras

Before accessing the IP camera, make sure that the camera's RJ-45 network, audio, and power cables are properly connected. To set the IP address, consult your network administrator for an available IP address. The default IP address for each IP camera is **192.168.0.200**. Users can use the default IP address for verifying the camera's network connection.

6 Software Requirements

When login to the IP camera by Internet Explorer, the pop-up box will prompt (OS Win10 excluded) the installation of the Universal ActiveX. Click **Install** to download it.



7 Configuring IP Addresses via Web Interface

Set your PC Address the same network segment as the default IP address (192.168.0.200). Key in the default iCAM IP address in the web browser and follow the steps below:

1. Login to the iCAM by key in the default username “**admin**” and password “**pass**”.
2. When log in, click upper right “**Setup**” to get to following capture page

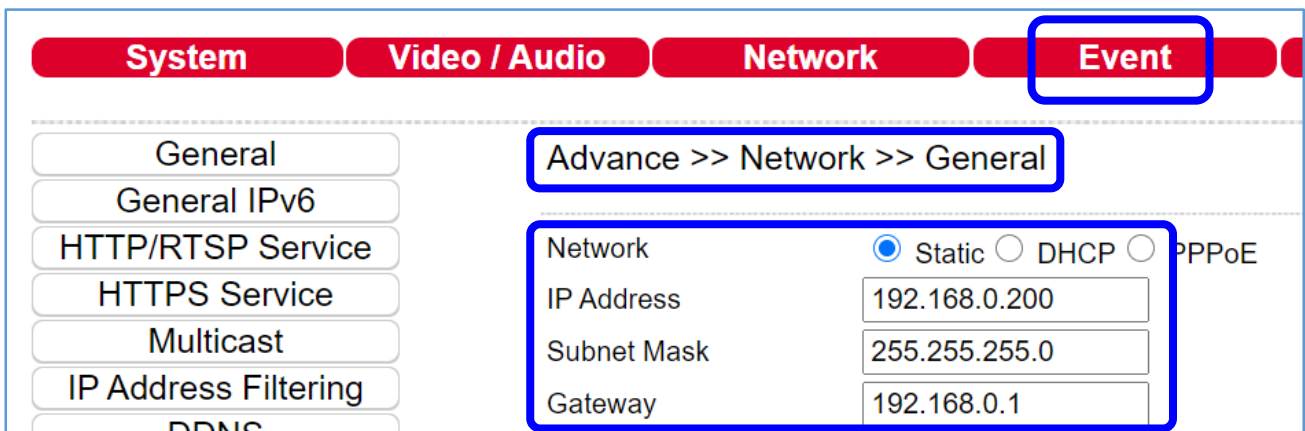

3. Click “**Network**” and get into “**General**”
4. Set the **IP address**, **Subnet Mask**, and **Gateway** to the required one
5. Click **Submit** to verify all settings.

8 Configuring IP Addresses with IPScan Software

【OR】 To change the settings of the IP address, Subnet Mask, Gateway, or etc., you can follow the steps below:

1. Run **IPScan** Software (or other **IP Scanner software** is accepted)
2. Click **Refresh/Scan**. All available devices should be shown in the list
3. Click to set the **IP address**, **Subnet Mask**, **Gateway** to the required one
4. Click **Apply** to confirm the settings and verify settings.

9 Internet Properties & Security Settings

Make sure your Internet browser allows the ActiveX plug-in to work on your computer. Set

Download Signed ActiveX controls to **“Prompt”** and **Run ActiveX controls and plug-ins** to **“Enable”** . You can set this option through **Control Panel**→**Network and Internet**→**Manage**

Browser Add-ons→**Internet Properties**→**Security**→**Custom Level**.

Once complete, you can access the iCAM live video by entering the default IP address via your web browser. As the security warning dialog appears, click **OK** to download the ActiveX directly from the iCAM.

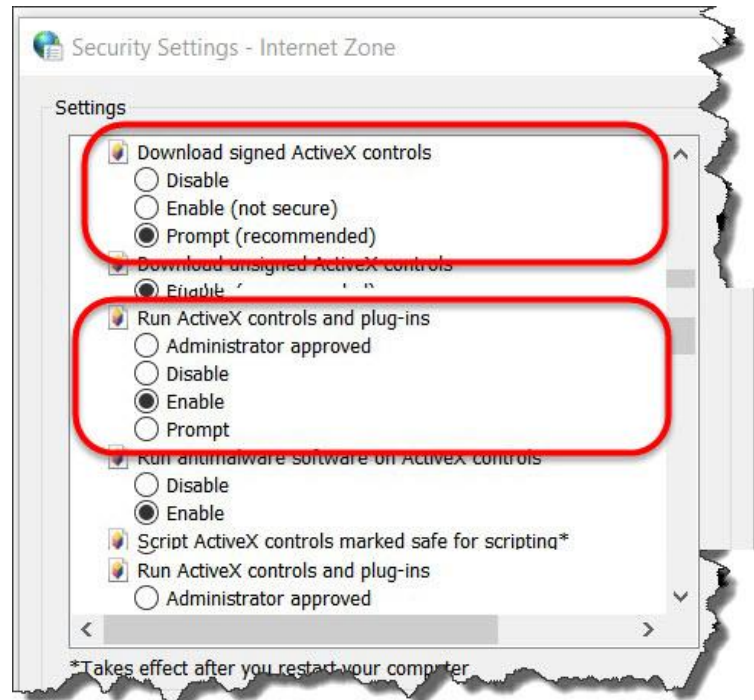

10 Sign In

Please key in following Default Username and Password when the right-side dialog box pop-ups.

Default Username/password :

| | |
|-----------------|--------------|
| Username | admin |
| Password | pass |

