



# IES6300-8GHP2GS2HS-2P48-360W

## Managed Industrial PoE++ Ethernet Switch

### Quick Installation Guide

#### 【Package Checklist】

Please check the integrity of package and accessories while first using the switch.

1. Industrial Ethernet switch
2. DIN-Rail mounting attachment
3. Certification
4. Warranty card

If any of these items are damaged or lost, please contact our company or dealers, we will solve it ASAP.

#### 【Product Overview】

This product is Gigabit managed DIN-Rail industrial PoE++ Ethernet switch. The model is IES6300-8GHP2GS2HS-2P48-360W-N (8 Gigabit PoE + 2 100M/1G SFP + 2 100M/1G/2.5G SFP + 2 DI + 2 DO, 50~55VDC redundant power input, 360W PoE++ power output).

#### 【Panel Design】

➤ Top view, bottom view and rear view

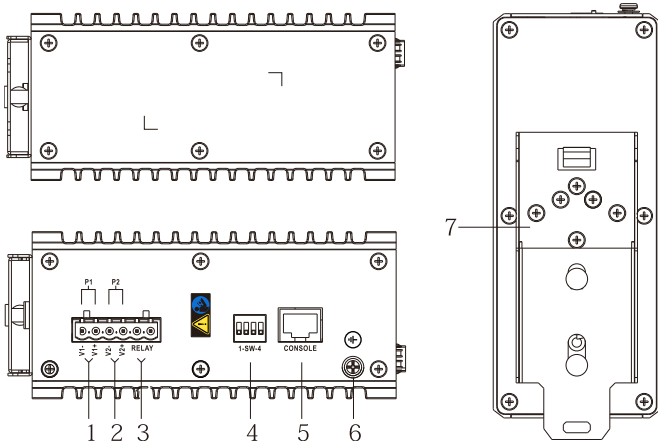

➤ Main view and right view

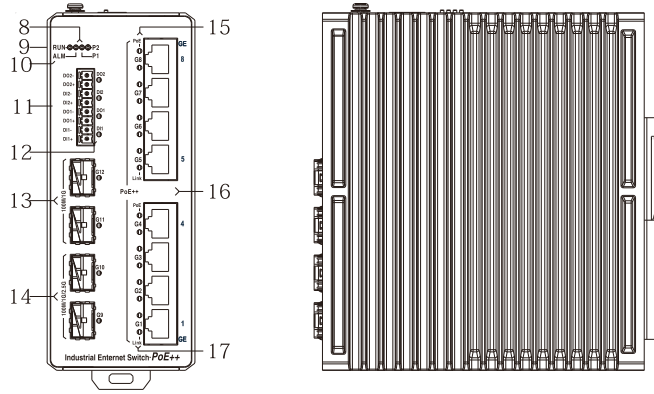

1. Input terminal blocks for Power Supply P1
2. Input terminal blocks for Power Supply P2
3. Relay alarm output terminal block
4. DIP switch
5. Console port
6. Grounding screw
7. DIN-Rail mounting kit
8. Power supply indicator (P1-P2)
9. Running indicator (RUN)
10. Alarm indicator (ALM)
11. I/O input and output interfaces (DI1-DI2, DO1-DO2)
12. I/O indicator (DI1-DI2, DO1-DO2)
13. 100/1000Base-X SFP slot (G11-G12)
14. 100/1000/2.5GBase-X, SFP slot (G9-G10)
15. PoE indicator (G1-G8)
16. 10/100/1000Base-T(X) Gigabit PoE copper port (G1-G8)
17. Ethernet port indicator (G1-G12)

#### 【Mounting Dimension】

Unit: mm

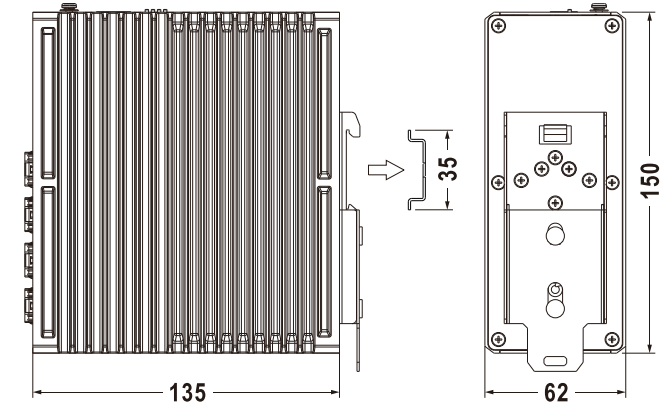

#### ⚠ Notice Before Mounting:

- Don't place or install the device in area near water or moist, keep the relative humidity of the device surrounding between 5%~95% without condensation.
- Before power on, first confirm the supported power supply specification to avoid over-voltage damaging the device.
- The device surface temperature is high after running; please don't directly contact to avoid scalding.

#### 【DIN-Rail Mounting】

The product adopts 35mm standard DIN-Rail mounting which is suitable for most industrial scenes, mounting steps as follows:

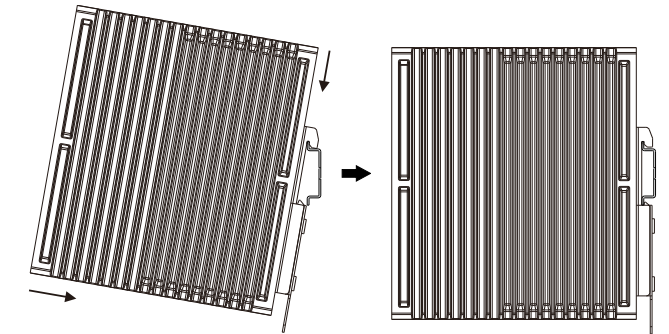

- Step 1 Check if the DIN-Rail mounting kit is installed firmly.
- Step 2 Clip the upper part of the DIN-Rail mounting kit, i.e. the fixed side, into the DIN rail.
- Step 3 Press the lower side of the device and insert the

lower part of DIN-Rail mounting kit (the side with spring support) into DIN-Rail.

Tips:

The DIN-Rail spring support is a metal sheet that can move up and down, and there will be a sound after it is clamped in.

**Step 4** Check and confirm the product is firmly installed on DIN rail, then mounting ends.

### 【Disassembling DIN-Rail】

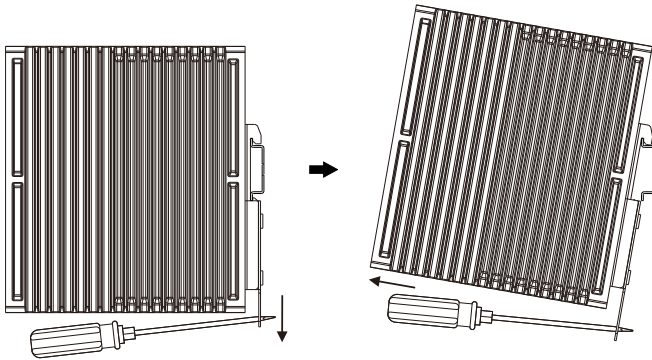

**Step 1** Power off device.

**Step 2** Use a slot type screwdriver or other tools to move the DIN rail spring support downward; At the same time, move the lower side of the device outward and move out the lower part of the DIN rail mounting kit.

**Step 3** Lift the device upward slightly, move out the upper part of DIN-Rail mounting kit. Disassembling ends.



#### Notice before power on:

- Power ON operation: First insert the power supply terminal block into the device power supply interface, then plug the power supply plug contact and power on.
- Power OFF operation: First, remove the power plug, then remove the wiring section of terminal block. Please pay attention to the above operation sequence.

### 【Power Supply Connection】

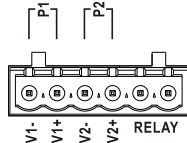

The device provides 6-pin 5.08mm pitch power supply terminal blocks and power supply occupies the left 4 pins. It supports two independent DC power supply systems, P1 and P2. The series of device supports redundant power supply, two power supply can work at the same time. The device will still run non-stop when one power supply fails. Power supply supports anti-reverse connection, which protect the device from damage but the device cannot be powered on. The definitions of power pin are shown in the figure above, and the power input range is 50~55VDC.



#### Note:

- If the POE port uses IEEE802.3bt PoE++ standard, the device power input range must be 50~55VDC;
- If the POE port uses IEEE802.3af/at PoE/PoE+ standard, the device power input range is 48~55VDC.

### 【Relay Connection】

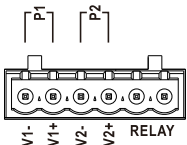

This device provides 6-pin 5.08mm pitch terminal blocks, relay occupies the right 2 pins. Relay terminals are a set of normally open contacts of the device alarm relay. They are open circuit in the state of normal non alarm, closed when any alarm information occurs. For example, they are closed when powered off, and send out alarm. The switch supports 1 relay alarm information output that can output power supply alarm or network abnormality alarm. It can be connected to alarm light or alarm buzzer or other switching value collecting devices, which can timely inform operators when the alarm occurs.

### 【DIP Switch Settings】



The device provides 4-pin DIP switch for function setting, in which "ON" is the enabled end. The definitions of DIP switch are as follows:

DIP	Definition	Operation
1	Restore Factory Settings	Set the DIP switch to ON, the device will root automatically and restore to factory settings, then turn off the DIP switch.
2-4	Reserved	—

### 【I/O Port Connection】

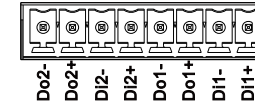

This device provides 8-pin 3.81mm pitch terminal blocks and 2 DI and 2 DO.

This device can detect and send I/O input status to management software, operators can set the conditions of alarm status via management software. When the I/O input status meets the set alarm conditions, the I/O output alarm would be triggered. The pin definitions of I/O port are shown as follows:

I/O Port	PIN	Definition
DI digital signal input 1	DI1+, DI1-	I/O signal input
DI digital signal input 2	DI2+, DI2-	
DO digital signal output 1	DO1+, DO1-	I/O relay output
DO digital signal output 2	DO2+, DO2-	

### 【Console Port Connection】

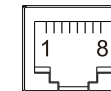

The device provides 1 program debugging port based on RS-232 serial port which can conduct device CLI command management after connecting to PC. The interface adopts RJ45 port, the RJ45 pin definition as follows:

Pin No.	2	3	5
Definition	TXD	RXD	GND

### 【Checking LED Indicator】

The device provides LED indicators to monitor its operating status, which has simplified the overall troubleshooting process. The function of each LED is described in the table below:

LED	Indicate	Description
P1-P2	ON	Power supply is running normally
	OFF	Power supply is disconnected or running abnormally
RUN	ON	Device is not started or abnormal

	Blinking	Blinking 1 time per second, system is running normally
	OFF	The device is powered off or the device is abnormal.
ALM	ON	Power supply or port link has alarm
	OFF	Power supply and port link have no alarm
LINK (G1-G12)	ON	Ethernet port has established a valid network connection
	Blinking	Ethernet port is in an active network status
	OFF	Ethernet port has not established valid network connection
PoE (G1-G8)	ON	POE port is powering other PD devices normally
	OFF	POE is disabled or disconnected
DI (1-2)	ON	I/O has input information
	OFF	I/O has no input information
DO (1-2)	ON	I/O has output alarm information, and it's status is on.
	OFF	I/O has no output alarm information, and it's status is off.

### 【Logging in to WEB Interface】

This device supports WEB management and configuration. Computer can access the device via Ethernet interface. The way of logging in to device's configuration interface via IE browser is shown as below:

**Step 1** Configure the IP addresses of computer and the device to the same network segment, and the network between them can be mutually accessed

**Step 2** Enter device's IP address in the address bar of the computer browser.

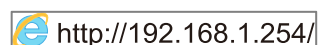
 http://192.168.1.254/

**Step 3** Enter device's username and password in the login window as shown below.

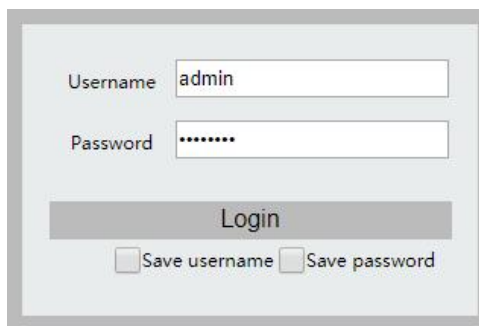

**Step 4** Click the “login” button. Change the initial password when logging into the device for the first time, after that, relog into the device to access the device's Web interface.



#### Note:

- The default IP address of the device is “192.168.1.254”.
- The default user name and password of the device are “admin”.
- When logging in to the device for the first time, the system will prompt to change the initial password of the default user; The length of the new password string must be greater than or equal to 8 and be composed of two or more kinds of uppercase letters, lowercase letters, numbers and special characters.
- If the user name or password is lost, the factory settings can be restored through the DIP switch or management software of the device; Or make a physical loopback between Port 1 and Port 2 within the first minute when the switch restarts.
- Please refer to user manual for specific configuration method of logging in to WEB interface and other configurations about network management function.

### 【Specification】

Panel	
Gigabit PoE++ port	10/100/1000Base-T(X) self-adaption, RJ45, Full/Half Duplex, MDI/ MDI-X self-adaption. The single port supports 15.4W PoE output power of IEEE802.3af standard and 30W PoE+ output power of IEEE802.3at standard, power supply pin: 1/2-, 3/6+; 90W PoE++ output power of IEEE802.3bt standard, power supply pin: 1/2-, 3/6+, 4/5-, 7/8+
Gigabit SFP slot	100/1000Base-X self-adaption or forced mode, SFP slot
2.5G SFP slot	100/1000/2.5GBase-X self-adaption or forced mode, SFP slot
I/O port	Support 2 inputs and 2 outputs, 8-pin 3.81mm pitch terminal blocks, support dry contact input and relay-type output
Console port	CLI command management port (RS-232), RJ45
Alarm interface	6-pin 5.08mm pitch terminal blocks, the alarm occupies 2 pins, support 1 relay alarm information output, the current load capacity is 1A@30VDC or 0 3A@125VAC
Indicator	Running indicator, alarm indicator, power supply indicator, interface indicator, PoE indicator, I/O output indicator, I/O input indicator
Switch Property	
Backplane bandwidth	30G

Packet buffer size	4Mbit
MAC Address Table	8K
<b>Power Supply</b>	
Input power supply	50~55VDC redundant power supply Support anti-reverse connection and 7.5A overcurrent protection
Access terminal block	6-pin 5.08mm pitch terminal blocks (power supply occupies 4 pins)
<b>Power Consumption</b>	
No-load	≤5.5W@50VDC
Full-load	≤ 380W@50VDC (with 360W PoE Load)
<b>Working Environment</b>	
Working temperature	-40~75°C
Storage temperature	-40~85°C
Working humidity	5%~95% (no condensation)
Protection grade	IP40 (metal shell)

### 【Disposal of Waste Electrical and Electronic Equipment (WEEE 2012/19/EU)】

(Applicable in the EU-member states)



The crossed-out wheeled bin symbol on the equipment or its packaging indicates that the product, at the end of its service life, shall not be mixed with unsorted municipal waste but should be collected separately, in accordance with local laws and regulations.

A proper separate collection of end-of-life equipment for the subsequent recycling, treatment and environmentally compatible disposal, will help prevent potential damage to the environment and human health,

facilitating the reuse, recycling and/or recovery of its component materials.

Private users should contact their vendor or municipal waste management service and ask for disposal information.

Professional users should contact their suppliers and check the terms of their selling agreement.

This product must not be disposed of with other commercial waste.

Users' cooperation in the correct disposal of this product will contribute to saving valuable resources and protecting the environment.