



IES2005-PN Unmanaged Industrial Ethernet Switch Quick Installation Guide

【Package checklist】

Please check whether the package and accessories are intact while using the switch for the first time.

1. Industrial Ethernet switch
2. Certification
3. DIN-Rail mounting attachment
4. Warranty card

If any of these items are damaged or lost, please contact our company or dealers, we will solve it ASAP.

【Product Overview】

This product is full 100M unmanaged DIN-Rail industrial Ethernet switch. The model is IES2005-PN (5 100M copper ports + 1 12~48VDC/24VAC power supply)

【Panel design】

➤ Rear view, bottom view and top view

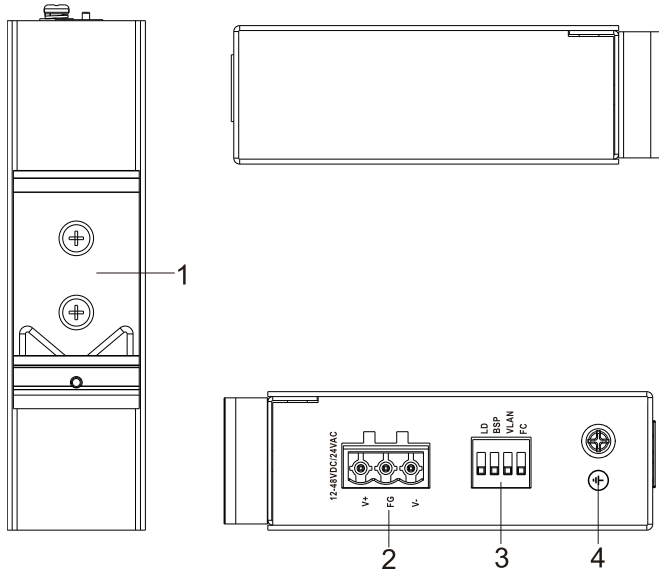

➤ Front view and side view

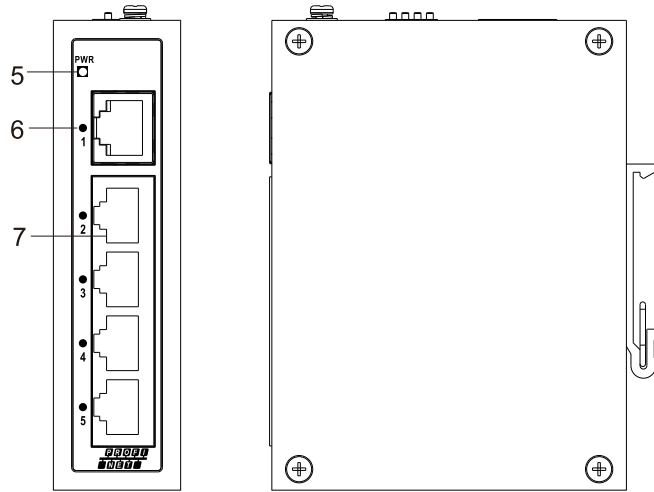

1. DIN-Rail mounting kit
2. Power supply input terminal block
3. DIP switch
4. Grounding screw
5. Power supply input status indicator PWR
6. Copper port connection indicator
7. 100M Ethernet copper port

【Mounting Dimension】

Unit: mm

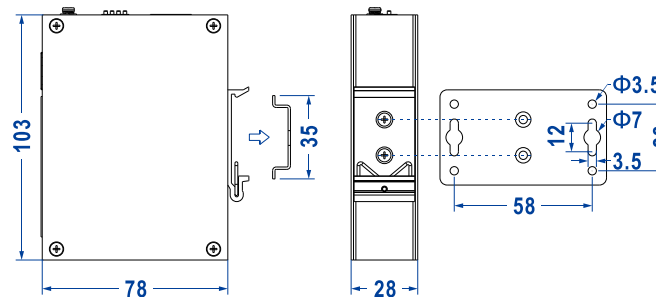

Attention before mounting:

- Don't place or install the device in area near water or moist, keep the relative humidity of the device surrounding between 5%~95% without condensation.
- Before power on, first confirm the supported power

supply specification to avoid over-voltage damaging the device.

- The device surface temperature is high after running; please don't directly contact to avoid scalding.

【DIN-Rail Mounting】

For convenient usage in industrial environments, the product adopts 35mm DIN-Rail mounting, mounting steps as below:

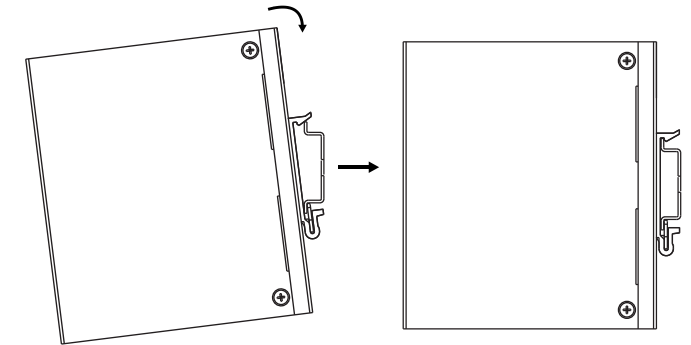

Step 1 Check whether the DIN-Rail mounting kit that comes with the device is installed firmly.

Step 2 Insert the bottom of DIN-Rail mounting kit (one side with spring support) into DIN-Rail, and then insert the top into DIN-Rail.

Tips:

Insert a little to the bottom, lift upward and then insert to the top.

Step 3 Check and confirm the product is firmly installed on DIN-Rail, and then mounting ends.

【Disassembling DIN-Rail】

Step 1 Power off the device.

Step 2 After lift the device upward slightly, first shift out the top of DIN-Rail mounting kit, and then shift out the bottom of DIN-Rail, disassembling ends.



Attention before powering on:

- Power ON operation: first connect power line to the connection terminal of device power supply, and then power on.

- Power OFF operation: first unpin the power plug, and then remove the power line, please note the operation order above.

【Power Supply Connection】

➤ DC power supply

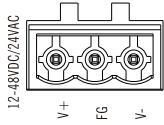

This series provide 3-pin 5.08 pitch power input terminal blocks. Power supply range: 12~48VDC/24VAC

【DIP Switch Settings】

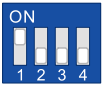

It provides 4-pin DIP switch for function settings, among which “ON” is enable valid end.

The definitions of DIP switch are as follows:

DIP	Definition	Operation
1	Loop detection	Set the DIP switch to ON to enable the loop detection function. Note: 1. The default configuration of DIP switch 1 is ON. 2. To improve the communication quality, it is recommended to set DIP switch 1 to ON.
2	Storm suppression	Set the DIP switch to ON to enable the storm suppression function.
3	One-key VLAN	Set the DIP switch to ON to enable VLAN function, port 1 can communicate with other ports, while other ports are isolated from each other.
4	Flow control	Set the switch to ON to enable the flow control function

【Checking LED Indicator】

The function of each LED is described in the table as below:

LED	Status	Description
PWR	ON	Power supply is connected and running normally
	OFF	Power supply is disconnected and running abnormally.
Link/ACT (1-5)	ON	Ethernet port connection is active.
	Blinking	Data transmitted
	OFF	Ethernet port connection is inactive.

【Specification】

Panel	
100M copper port	10/100Base-T(X) self-adapting RJ45 port, full/half duplex self-adaption, support MDI/MDI-X self-adaption
Indicator	Power indicator, interface indicator
Exchange attributes	
Backplane bandwidth	1G
MAC table size	2K
Power supply	
Input power supply	12~48VDC/24VAC
Access terminal	3 pins 5.08mm pitch terminal blocks Support anti-reverse connection and over-current protection
Consumption	
No-load	0.4W@24VDC
Full-load	1.0W@24VDC
Environmental Limits	
Working temperature	-40~75℃
Storage temperature	-40~85℃
Working humidity	5%~95% (no condensation)
Protection grade	IP40 (metal shell)

MTBF	510465 hrs
------	------------

【Disposal of Waste Electrical and Electronic Equipment (WEEE 2012/19/EU)】

(Applicable in the EU-member states)



The crossed-out wheeled bin symbol on the equipment or its packaging indicates that the product, at the end of its service life, shall not be mixed with unsorted municipal waste but should be collected separately, in accordance with local laws and regulations.

A proper separate collection of end-of-life equipment for the subsequent recycling, treatment and environmentally compatible disposal, will help prevent potential damage to the environment and human health, facilitating the reuse, recycling and/or recovery of its component materials.

Private users should contact their vendor or municipal waste management service and ask for disposal information.

Professional users should contact their suppliers and check the terms of their selling agreement.

This product must not be disposed of with other commercial waste.

Users' cooperation in the correct disposal of this product will contribute to saving valuable resources and protecting the environment.