



ICS6400BT-8GP4XS-2LV Layer 3 Industrial Ethernet Switch Quick Installation Guide

【Package Checklist】

Please check the integrity of package and accessories while first using the switch.

1. Industrial Ethernet switch
2. DIN-Rail mounting attachment
3. Certificate
4. Warranty card

If any of these items are damaged or lost, please contact our company or dealers, we will solve it ASAP.

【Product Overview】

This product is Gigabit/10Gigabit DIN-Rail layer 3 industrial Ethernet switch. Model: ICS6400BT-8GP4XS-2LV-N (8 Gigabit PoE copper ports+4 10 Gigabit SFP slots+1 USB interface, 2 48VDC (44-57VDC) redundant power inputs).

【Panel Design】

➤ Front view and right view

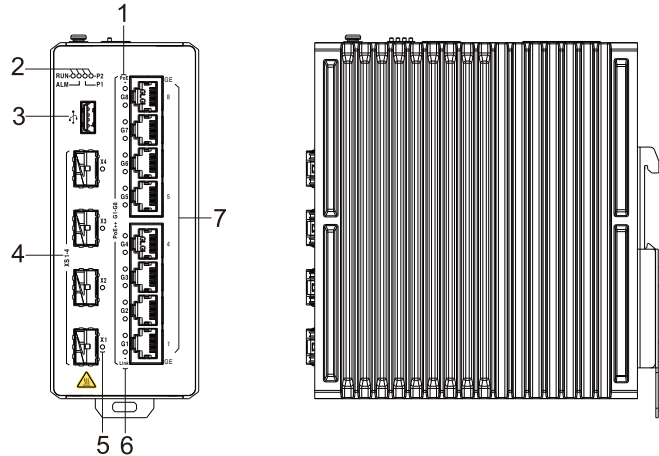

➤ Rear view, bottom view and top view

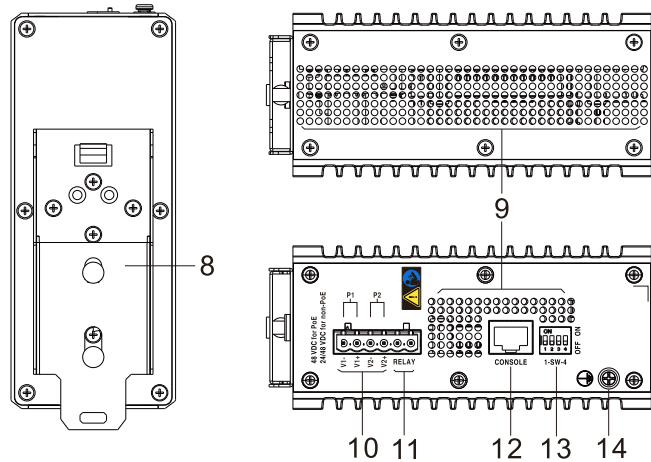

1. PoE indicator (PoE, G1-G8)
2. Indicators, from left to right in turn they are:
 - Running indicator (RUN)
 - Alarm indicator (ALM)
 - Power supply indicator (P1-P2)
3. USB 2.0 interface (reserved)
4. 10Gigabit SFP slot (X1-X4)
5. 10Gigabit SFP indicator (X1-X4)
6. Gigabit PoE copper port indicator (Link, G1-G8)
7. Gigabit PoE copper port (G1-G8)
8. DIN-Rail mounting kit
9. Heat dissipation hole
10. Terminal blocks for DC power input (P1, P2)
11. Terminal blocks for relay alarm output (RELAY)
12. CONSOLE port
13. DIP switch (1-SW-4)
14. Grounding screw (M4)

【Mounting Dimension】

Unit: mm

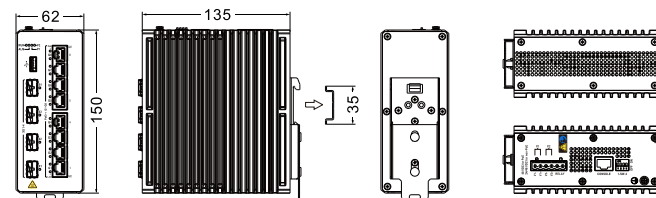

Notice Before Mounting:

- Don't place or install the device in area near water or moisture, keep the relative humidity of the device surrounding between 5%~95% without condensation.
- Before powering on the device, check the power specifications supported by the device to prevent device damage due to overvoltage.
- The device surface temperature is high after running; please don't directly contact to avoid scalding.

【DIN-Rail Mounting】

The product adopts 35mm standard DIN-Rail mounting which is suitable for most industrial scenes, mounting steps are as follows:

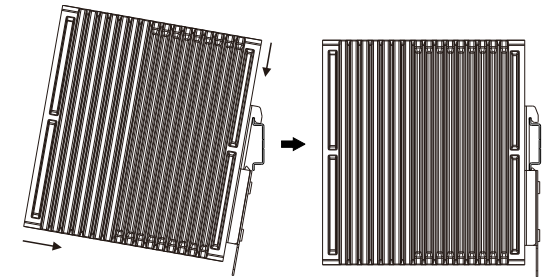

- Step 1** Check if the DIN-Rail mounting kit is installed firmly.
- Step 2** Clip the upper part of the DIN-Rail mounting kit, i.e., the fixed side, into the DIN rail.
- Step 3** Press the lower side of the device and insert the lower part of DIN-Rail mounting kit (the side with spring support) into DIN-Rail.
Tips:
The DIN-Rail spring support is a metal sheet that can move up and down, and there will be a sound after it is clamped in.
- Step 4** Check and confirm the product is firmly installed on DIN rail, then mounting ends.

【Disassembling DIN-Rail】

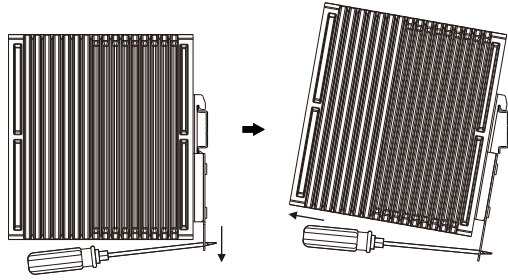

- Step 1** Power off the device.
- Step 2** Use a slot type screwdriver or other tools to move the DIN rail spring support downward; At the same time, move the lower side of the device outward and move out the lower part of the DIN rail mounting kit.
- Step 3** Lift the device upward slightly, move out the upper part of DIN-Rail mounting kit. Disassembling ends.



Notice Before Powering on:

- Power ON operation: First insert the power supply terminal block into the device power supply interface, and then plug the power supply plug and power on.
- Power OFF operation: First, remove the power plug, then remove the wiring section of terminal block. Please pay attention to the above operation sequence.

【Power Supply Connection】

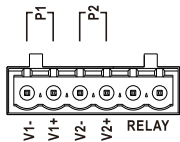

Provides 6-pin 5.08mm pitch power supply terminal blocks and power supply occupies the left 4 pins. It supports two independent DC power supply systems, P1 and P2. The power input supports 1 power supply alone

or 2 power supply at the same time; When two power supply input at the same time, it supports redundant backup of power supply. If one power supply fails, the device can still work normally without interruption. Power supply supports anti-reverse connection, which protect the device from

damage but the device cannot be powered on. The definitions of power pin are shown in the figure above, and the power input range is 48VDC (44~57VDC).

【Relay Connection】

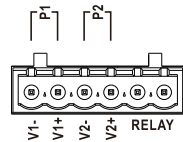

This device provides 6-pin 5.08mm pitch terminal blocks, RELAY occupies the right 2 pins. Support 1 relay alarm output. The relay supports the output of DC power supply alarm or network abnormality alarm.

It can be connected to alarm light or alarm buzzer or other switching value collecting devices, which can timely inform operators when the alarm occurs. The default relay status is shown in the figure below.

Device Status	Relay Contacts	Alarm
Not powered on or powered off	Closed	Yes
Powered on, but not working properly	Closed	Yes
Powered on, and working properly without triggering any alarm	Disconnected	None
Powered on, and working properly, but it triggered alarms	Closed	Yes

【DIP Switch Settings】

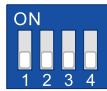

The device provides 4-pin DIP switch for function setting, in which "ON" is the enabled end.

The definitions of DIP switch are as follows:

No.	Definition	Operation
1	Reboot or restore factory settings	Set the switch to "ON" - hold for more than 1 second, and then dial back to restart the device; - Hold for more than 5 second, and then dial back, the device would restore factory settings and automatically restart.
2-4	Reserved	—

【Console Port Connection】

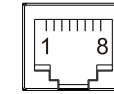

The device provides 1 program debugging port based on RS-232 serial port which can conduct device CLI command management after connecting to PC. The interface adopts RJ45 port, the RJ45 pin definition is as follows:

Pin No.	2	3	5
Definition	TXD	RXD	GND

【Checking LED Indicator】

The device provides LED indicators to monitor its operating status, which has simplified the overall troubleshooting process. The function of each LED is described in the table below:

LED	Indicate	Description
P1-P2	ON	Power supply is running normally
	OFF	Power supply is disconnected or running abnormally
RUN	ON	The device is running abnormally
	Blinking	Blinking 1 time per second, system is running normally
	OFF	The device is powered off or the device is abnormal.
ALM	ON	Power supply or port link has alarm
	OFF	Power supply, port link without alarm
LINK (X1-X4, G1-G8)	ON	Ethernet port has established a valid network connection
	Blinking	Ethernet port is in an active network status
	OFF	Ethernet port has not established a valid network connection
PoE (G1-G8)	ON	POE port is powering other PD devices normally
	OFF	POE is disabled or PD device is disconnected

【Logging in to WEB Interface】

This device supports WEB management and configuration. Computer can access the device via Ethernet interface. The way of logging in to device's configuration interface via IE browser is shown as below:

Step 1 Configure the IP addresses of computer and the device to the same network segment, and the network between them can be mutually accessed.

Step 2 Enter device's IP address in the address bar of the computer browser.

http://192.168.1.254

Step 3 Enter device's username and password in the login window as shown below.

Step 4 Click the “login” button. Change the initial password when logging into the device for the first time, after that, relog into the device's Web interface.



Note:

- The default IP address of the device is “192.168.1.254”.
- The default username and password of the device is “admin123”.
- When logging in to the device for the first time, the system will prompt to change the initial password of the default user; The length of the new password string must be greater than or equal to 8 and be composed of two or more kinds of uppercase letters, lowercase letters, numbers, and special characters.
- If the username or password is lost, user can restore it to

factory settings via device DIP switch or management software.

- Please refer to user manual for specific configuration method of logging in to WEB interface and other configurations about network management function.

【Specification】

Panel	
Gigabit PoE copper port	10/100/1000Base-T(X) adaptive or forced mode, RJ45, automatic flow control, full/half duplex mode adaptive, MDI/MDI-X automatic detection; A single port supports a maximum of 90W PoE power supply output. PoE power supply pin 1 and 2 are positive, 3 and 6 are negative, 4 and 5 are positive, and 7 and 8 are negative
10Gigabit SFP slot	1G/2.5G//10G Base-X self-adaption or forced mode, SFP+ slot
Console port	CLI command management port (RS-232), RJ45
Alarm port	6-pin 5.08mm pitch terminal blocks, alarm occupies 2-pin, supports 1 relay alarm information output, current load capacity is 1A@30VDC or 0.3A@125VAC or 5A@250VAC
Indicator	Running Indicator, Alarm Indicator, Power Supply Indicator, Interface Indicator, PoE Indicator
Switch Property	
Backplane bandwidth	128Gbps
Buffer size	12Mbit
MAC address table	16K
Power Supply	

Power input	2 48VDC (44~57VDC), dual power redundancy, and supports anti-reverse connection
Connection mode	Adopt 6-pin 5.08mm pitch terminal blocks, power supply occupies 4 pins
Power Consumption	
No-load at normal temperature	6.72W@48VDC
Full-load at normal temperature	352.3W@48VDC (with PoE)
No-load at high temperature	9.22W@48VDC
Full-load at high temperature	357.6W@48VDC (with PoE)
Working Environment	
Working temperature	-40~75℃
Storage temperature	-40~85℃
Working humidity	5%~95% (no condensation)
Protection grade	IP30 (metal shell)

【 Disposal of Waste Electrical and Electronic Equipment (WEEE 2012/19/EU)】

(Applicable in the EU-member states)



The crossed-out wheeled bin symbol on the equipment or its packaging indicates that the product, at the end of its service life, shall not be mixed with unsorted municipal waste but should be collected separately, in accordance with local laws and regulations.

A proper separate collection of end-of-life equipment for the subsequent recycling, treatment, and environmentally compatible disposal, will help prevent potential damage to the environment and human health, facilitating the reuse, recycling and/or recovery of its component materials.

Private users should contact their vendor or municipal waste management service and ask for disposal information.

Professional users should contact their suppliers and check the terms of their selling agreement.

This product must not be disposed of with other commercial waste.

Users' cooperation in the correct disposal of this product will contribute to saving valuable resources and protecting the environment.