



## MES5300 Series

19-inch 1U Rack Mounting

28-port Gigabit/10Gigabit Layer 3 Managed Industrial Ethernet Switch

- Support 24 Gigabit copper ports or SFP slots, 4 10Gigabit SFP+ slots
- Support MRP ring network, reconfiguration time < 200ms
- Support multiple network protocols and industrial standards, such as ARP, STP/RSTP/MSTP, ERPS, VLAN, LACP, IGMP Snooping, LLDP, SNMP, etc., support Modbus TCP monitoring instruction of electricity SCADA system
- Support IEC61850 MMS modeling and management, ensuring the efficient, reliable, and standardized communication between substation devices
- DC product supports 2 24/48VDC (18-72VDC), dual power supply redundancy, support non-polarity
- AC product supports 2 110/ 220VAC/DC (85-305VAC/88-430VDC), dual power supply redundancy
- Support -40~75 °C wide temperature operation, support level 4 electromagnetic compatibility protection, and conform to IEC 61850-3 and IEEE 1613 (substation) standards
- Support IP40 protection grade



IEC 61850



Industrial Grade



RPS



# Introduction

---

MES5300 series products are 28-port Gigabit/10Gigabit layer 3 managed industrial Ethernet switches. Provide Gigabit copper port, Gigabit SFP slot, 10Gigabit SFP+ slot, which can negotiate the port rate and duplex mode with the device at the opposite end through self-negotiation. Support power supply solutions of 18~72VDC or 85~305VAC/88~430VDC, and adopt standard rack installation method, which is specially designed for extremely severe electromagnetic interference environment to meet the anti-interference requirements of power monitoring industry.

Network management system supports various network protocols and industrial standards, such as Static Routing, RIP, VRRP, NAT, STP/RSTP/MSTP, EPRS, 802.1Q VLAN, QoS, Modbus TCP function, DHCP Server, DHCP Client, IGMP Static Multicast, LLDP, Port Trunking, Port Mirroring, etc. It also possesses complete management functions, including Port Configuration, Port Statistics, Port IP Binding, Access Control, 802.1X Authentication, Network Diagnosis, Rapid Configuration, Online Upgrading and so on; and supports CLI, HTTP, HTTPS, Telnet, SSH and other access methods. Network management system could bring you great user experience through its friendly interface design and easy and convenient operation.

The input power supply is two independent power supply circuits which can ensure the normal operation of the device when one power supply fails. When power supply or port has link failure, ALM indicator will be bright and send out alarm, meanwhile, alarm device connected to the relay will send out alarm for rapid scene troubleshooting. The hardware adopts fanless, low power consumption and wide temperature and voltage design, which has passed rigorous industrial standard tests, and suits the industrial scene environment with harsh requirements for EMC. It can be widely used in smart substation, smart grid, energy storage, photovoltaic, wind electricity, non-electric industry SCADA system and other industrial fields.

## Features and Benefits

---

- ⦿ IEC61850 MMS modeling and management ensures efficient, reliable, and standardized communication between substation devices
- ⦿ SNMPv1/v2c/v3 is used for network management of various levels
- ⦿ RMON can be used for efficient and flexible network monitoring
- ⦿ QoS supports real-time traffic classification and priority setting
- ⦿ LLDP can achieve automatic topology discovery, which is convenient for visual management
- ⦿ DHCP server and DHCP client could be used for allocating IP address of different strategies
- ⦿ DHCP Snooping can ensure DHCP client gets IP address from legal DHCP server
- ⦿ DHCP relay function can realize IP address, gateway, DNS configuration cross

network segment

- ⊙ File management is convenient for the device rapid configuration and online upgrading
- ⊙ Log information and log server can record user operation, system failure, system security and other information locally and remotely
- ⊙ User privilege classification configuration can set user privilege level
- ⊙ ACL can enhance the flexibility and security of the network, supporting bidirectional ACL IN and OUT.
- ⊙ SSH configuration and HTTPS configuration can improve device's management security and guarantee data access security
- ⊙ Ring, MRP, STP/RSTP/MSTP can achieve network redundancy, preventing network storm
- ⊙ EPRS function can realize link backup and improve the reliability of network
- ⊙ Relay alarm is convenient for troubleshooting of construction site
- ⊙ Storm suppression can restrain broadcast, unknown multicast and unicast
- ⊙ VLAN is used for simplifying network planning
- ⊙ Port Trunking and LACP can increase network bandwidth and enhance the reliability of network connection to achieve optimum bandwidth utilization
- ⊙ IGMP/MLD Snooping can be used for filtering multicast traffic to save the network bandwidth
- ⊙ IGMP/MLD can be used to manage and maintain multicast members
- ⊙ ARP could be used for MAC address resolution
- ⊙ VRRP, RIP/RIPng, ISIS, OSPF/OSPFv3 and BGP can realize dynamic routing configuration
- ⊙ PIM-DM and PIM-SM can be used to create and maintain multicast routing table entries and realize multicast routing forwarding
- ⊙ NAT maps private IP address to the legal IP address of external network, which can slow the consumption of IP address space
- ⊙ Loop detection could efficiently eliminate the influence caused by port loopback by detecting the existence of loopback
- ⊙ IPDT can track IP device status and realize interaction with other applications
- ⊙ Smart Link link backup, providing reliable and efficient backup and fast switching mechanism
- ⊙ Network diagnosis and troubleshooting could be conducted via Ping, Traceroute, cable diagnosis, SFP DDMI
- ⊙ Port mirroring can conduct data analysis and monitoring, which is convenient for online debugging
- ⊙ Supports Modbus TCP monitoring, convenient for various integrated systems to monitor and manage device status

## Dimension

Unit: mm

- MES5300-24GT4XS-2LV

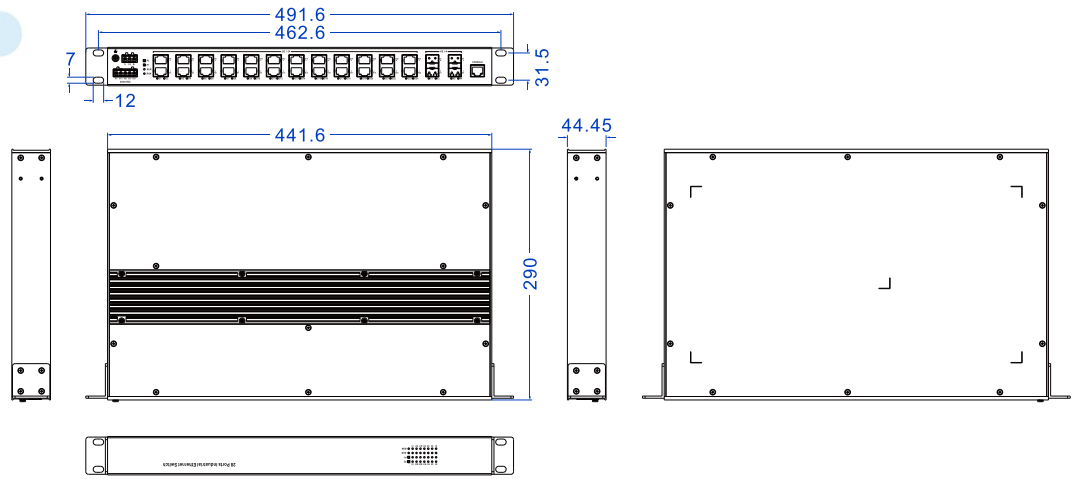

● MES5300-24GT4XS-2HV

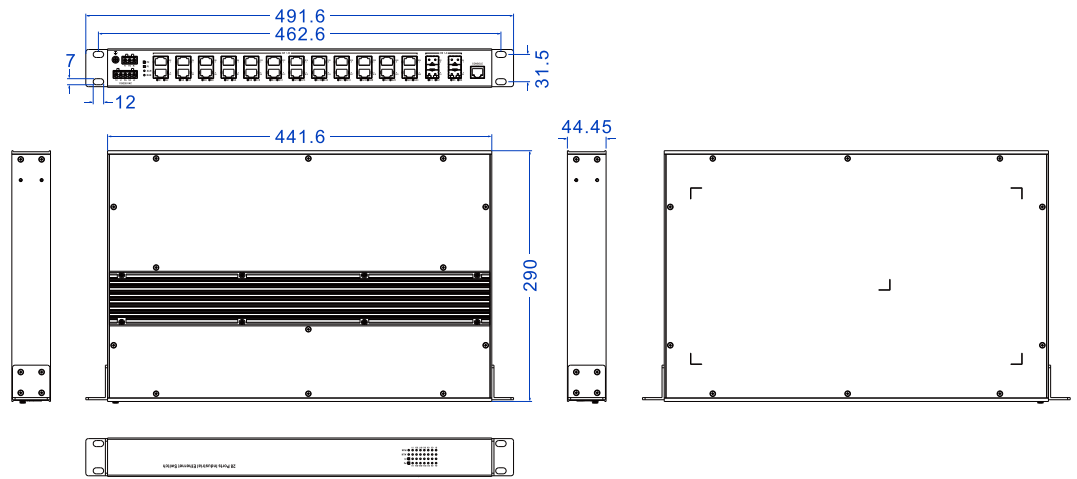

● MES5300-24GS4XS-2LV

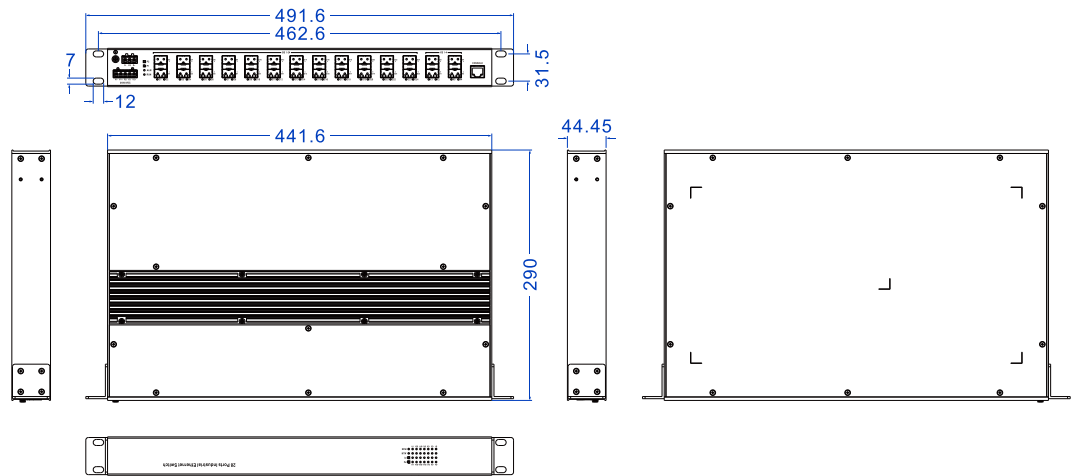

● MES5300-24GS4XS-2HV

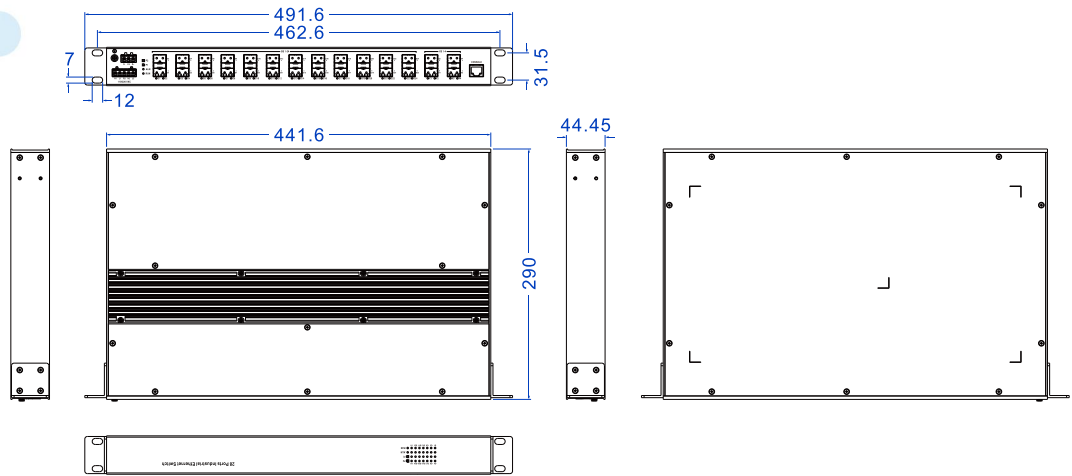

## Specification

<p>Standard &amp; Protocol</p>	<p>IEEE 802.3u for 100Base-TX          IEEE 802.3ab for 1000Base-T          IEEE 802.3z for 1000Base-X          IEEE 802.3ae for 10GBase-X          IEEE 802.3x for Flow Control          IEEE 802.1D for Spanning Tree Protocol          IEEE 802.1w for Rapid Spanning Tree Protocol          IEEE 802.1s for Multiple Spanning Tree Protocol          ITU-T G.8032 for ERPS          IEEE 802.1Q for VLAN          IEEE 802.1AB for LLDP          IEEE 802.3ad for LACP</p>
<p>Management</p>	<p>SNMP v1/v2c/v3 centralized management devices, RMON, port mirroring, LLDP, DHCP Server, DHCP Relay, Modbus TCP monitoring, IEC61850 MMS, DL/T 860 CMS, port speed limit, port isolation, port statistics, file management, online upgrade, log information, syslog server</p>
<p>Security</p>	<p>User privilege classification, ACL, SSH/HTTPS protocol authorization, link flapping protection, port loopback detection, access control, SNMP, RMON, IPDT, IPv6DT, Smart-Link, NAT, port alarm, temperature alarm, power alarm, network load alarm</p>
<p>Switch Function</p>	<p>802.1Q VLAN, MAC, static aggregation, LACP, ARP, storm suppression</p>
<p>Unicast / Multicast</p>	<p>IGMP-Snooping, MLD-Snooping, IGMP, MLD, PIM-SM, PIM-DM,</p>

	IPv6-PIM-SM, IPv6-PIM-DM
<b>Redundancy Technology</b>	Ring, MRP, STP/RSTP/MSTP, ERPS
<b>Routing Technique</b>	RIP, RIPng, OSPF, OSPFv3, ISIS, VRRP, IPv6 VRRP, BGP
<b>Troubleshooting</b>	Ping, Traceroute, Network Cable Diagnosis, DDMI
<b>Time Management</b>	NTP Client, Time Zone Configuration

<b>Interface</b>	<p>Gigabit copper port: 100/1000Base-T(X) self-adaption or forced mode, RJ45, Automatic Flow Control, Full/Half Duplex Mode self-adaption, MDI/MDI-X Autotuning</p> <p>Gigabit SFP: 100/1000Base-X SFP slot, 100M/Gigabit self-adaption</p> <p>10 Gigabit SFP+ slot: 10G Base-X SFP+ slot, supports forced 100M/1G/2.5G</p> <p>Console port: CLI command line management port (RS-232), RJ45</p> <p>Relay: Support 1 relay alarm output, adopt 3-pin 5.08mm pitch terminal blocks, the current carrying capacity is 2A@250VAC or 2A@220VDC</p>
------------------	--

<b>Indicator</b>	Power indicator, running indicator, alarm indicator, interface indicator
------------------	--

<b>Switch Property</b>	<p>Transmission mode: store and forward</p> <p>MAC address: 16K</p> <p>Cache: 12Mbit</p> <p>Backplane bandwidth: 128Gbps</p> <p>Switch delay: &lt;10μs</p>
------------------------	--

<b>Power Supply</b>	<p>Adopt 5-pin 5.08mm pitch terminal blocks</p> <ul style="list-style-type: none"> <li>DC product 2 24~48VDC (18-72VDC), dual power supply redundancy, support non-polarity</li> <li>AC product 2 110/220VAC/DC (85-305VAC/88-430VDC), dual power supply redundancy</li> </ul>
---------------------	--

<b>Power Consumption</b>	<p>MES5300-24GT4XS-2LV:</p> <ul style="list-style-type: none"> <li>No-load at normal temperature: 6.79W@48VDC</li> <li>Full-load at normal temperature: 21.5W@48VDC</li> <li>No-load at high temperature: 8.49W@48VDC</li> <li>Full-load at high temperature: 23.2W@48VDC</li> </ul>
--------------------------	--

	MES5300-24GT4XS-2HV:
--	----------------------

- No-load at normal temperature: 7.3W@220VAC
- Full-load at normal temperature: 21.4W@220VAC
- No-load at high temperature: 9.0W@220VAC
- Full-load at high temperature: 23.1W@220VAC

MES5300-24GS4XS-2LV:

- No-load at normal temperature: 15.7W@48VDC
- Full-load at normal temperature: 38.6W@48VDC
- No-load at high temperature: 19.7W@48VDC
- Full-load at high temperature: 42.6W@48VDC

MES5300-24GS4XS-2HV:

- No-load at normal temperature: 17.2W@220VAC
- Full-load at normal temperature: 38.5W@220VAC
- No-load at high temperature: 21.2W@220VAC
- Full-load at high temperature: 42.5W@220VAC

Operating temperature: -40~75°C

Storage temperature: -40~85°C

Relative humidity: 5%~95% (no condensation)

Working Environment

Mechanical Structure

Housing: IP40 protection, metal

Installation: 19-inch 1U rack mounting

Dimension (W x H x D): 491.6mm×44.45mm×290mm

Weight:

- MES5300-24GT4XS-2LV: 5.033kg
- MES5300-24GT4XS-2HV: 5.264kg
- MES5300-24GS4XS-2LV: 5.282kg
- MES5300-24GS4XS-2HV: 5.517kg

IEC 61000-4-2 (ESD, electronic static discharge), Level 4

- Air discharge: ± 15kV
- Contact discharge: ±8kV

IEC 61000-4-4 (EFT, electrical fast transient pulses), Level 4

- Power supply: ±4kV
- Copper port: ±2kV

IEC 61000-4-5 (Surge), Level 4

- Power supply: differential mode±2kV, common mode±4kV
- Copper port: differential mode±2kV, common mode±4kV

Shock: IEC 60068-2-27

Industrial Standard

Free fall: IEC 60068-2-31

Vibration: IEC 60068-2-6

Authentication

CE, FCC, RoHS, IEC 61850-3, IEEE 1613

Warranty

5 years

## Ordering Information

Model	Gigabit RJ45 LAN Port	Gigabit SFP	10Gigabit SFP+	Power Supply
MES5300-24GT4XS-2LV-N	24	—	4	2 24/48VDC (18~72VDC) redundant power inputs
MES5300-24GT4XS-2HV-N	24	—	4	2 110/220VAC/DC (85-305VAC/88-430VDC) redundant power inputs
MES5300-24GS4XS-2LV-N	—	24	4	2 24/48VDC (18~72VDC) redundant power inputs
MES5300-24GS4XS-2HV-N	—	24	4	2 110/220VAC/DC (85-305VAC/88-430VDC) power inputs