



MES5300-28GS Series

19-inch 1U Rack Mounting

28-Port Full Gigabit Layer 2 Managed Industrial Ethernet Switch

- Support 28 Gigabit SFP slots
- Support MRP ring network, reconfiguration time < 200ms
- Support multiple network protocols and industrial standards, such as ARP, STP/RSTP/MSTP, ERPS, VLAN, LACP, IGMP Snooping, LLDP, SNMP, etc., support Modbus TCP monitoring instruction of electricity SCADA system
- Support IEC61850-MMS, ensuring the efficient, reliable and standardized communication between substation devices
- DC product supports 2 24/48VDC (18-72VDC), dual power supply redundancy, support anti-reverse connection
- AC product supports 2 110/ 220VAC/DC (85-264VAC/77-300VDC), dual power supply redundancy
- Support -40~85°C wide temperature operation, support level 4 electromagnetic compatibility protection, and conform to IEC 61850-3 and IEEE 1613 (substation) standards



IEC 61850



Industrial Grade



RPS



Introduction

MES5300-28GS series products are 28-port full Gigabit layer 2 managed industrial Ethernet switches. This series provides Gigabit SFP slot, and adopts standard rack installation method, which is specially designed for extremely severe electromagnetic interference environment to meet the anti-interference requirements of power monitoring industry.

Network management system supports a variety of network protocols and industry standards, such as ARP, Ipv4, Ring, MRP, VLAN, STP/RSTP/MSTP, PTP, ERPS, LLDP, IGMP Snooping, Modbus TCP, QoS, port trunking, port mirroring, etc. It has perfect management functions, supporting port configuration, port statistics, ACL, 802.1X authentication, network diagnosis, rapid configuration, online upgrade, etc. CLI, WEB, Telnet, SNMP, SSH and other access methods can be supported. Network management system could bring you great user experience through its friendly interface design and easy and convenient operation.

The input power supply is two independent power supply circuits which can ensure the normal operation of the device when one power supply fails. When power supply or port has link failure, ALM indicator will be bright and send out alarm, meanwhile, alarm device connected to the relay will send out alarm for rapid scene troubleshooting. The hardware adopts fanless, low power consumption and wide temperature and voltage design, which has passed rigorous industrial standard tests, and suits the industrial scene environment with harsh requirements for EMC. It can be widely used in smart substation, smart grid, energy storage, photovoltaic, wind electricity, non-electric industry SCADA system and other industrial fields.

Features and Benefits

- ⦿ Precision Time Protocol (PTP), provide sub-microsecond synchronization accuracy to meet requirements for high-precision time synchronization
- ⦿ IEC61850-MMS ensures efficient, reliable and standardized communication between substation devices
- ⦿ SNMPv1/v2c/v3 is used for network management of various levels
- ⦿ RMON can be used for efficient and flexible network monitoring
- ⦿ Port mirroring can conduct data analysis and monitoring, which is convenient for online debugging
- ⦿ QoS supports real-time traffic classification and priority setting
- ⦿ LLDP can achieve automatic topology discovery, which is convenient for visual management
- ⦿ DHCP server and DHCP client could be used for allocating IP address of different strategies
- ⦿ DHCP Snooping can ensure DHCP client gets IP address from legal DHCP server

- File management is convenient for the device rapid configuration and online upgrading
- Log management records Console log, RAM log and Flash log
- Bandwidth management can reasonably distribute network bandwidth, preventing unpredictable network status
- Port statistics can be used for the port real time traffic statistics
- User password can conduct user hierarchical management to improve the device management security
- ACL can enhance network flexibility and security
- Relay alarm is convenient for troubleshooting of construction site
- Storm suppression can restrain broadcast, unknown multicast and unicast
- TELNET configuration and SSH configuration guarantee secure access to data
- Port Trunking can increase network bandwidth and enhance the reliability of network connection to achieve optimum bandwidth utilization
- IGMP Snooping and static multicast can be used to filter multicast data to save network bandwidth
- STP/RSTP/MSTP/Ring/MRP can achieve network redundancy, preventing network storm
- ARP could be used for MAC address resolution
- With high reliability and stability, ERPS could avoid broadcast storm caused by data loopback
- Network diagnosis and troubleshooting could be conducted via Ping, Traceroute, Cable Diagnosis, SFP Digital Diagnosis
- Supports Modbus TCP monitoring, convenient for various integrated systems to monitor and manage device status

Dimension

Unit: mm

MES5300-28GS-2LV

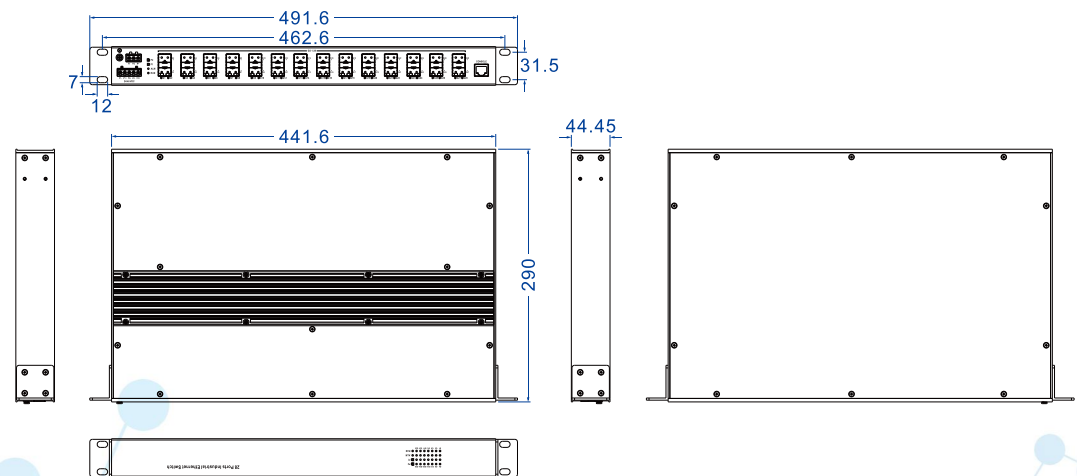

MES5300-28GS-2HV

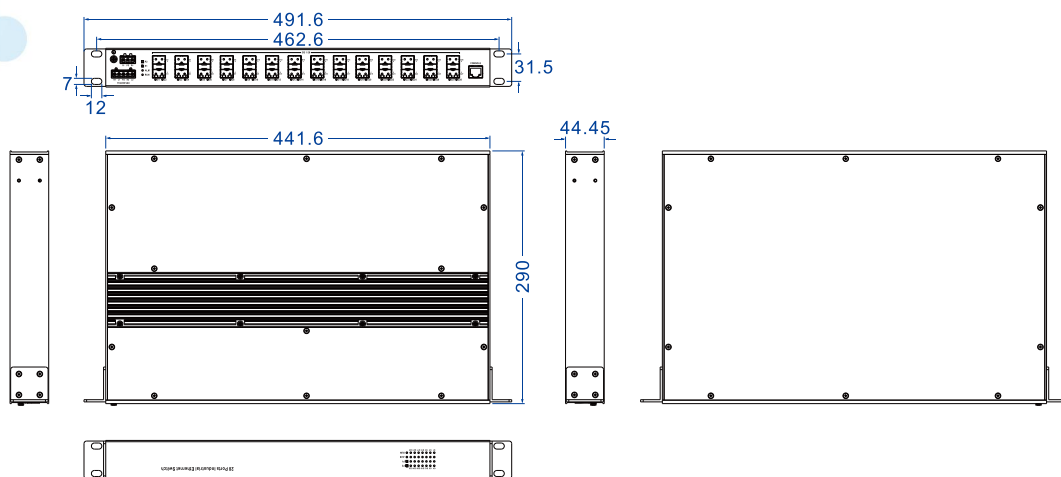

Specification

Standard & Protocol	<p>IEEE 802.3u for 100Base-FX IEEE 802.3z for 1000Base-X IEEE 802.3x for Flow Control IEEE 802.1D for Spanning Tree Protocol IEEE 802.1w for Rapid Spanning Tree Protocol IEEE 802.1s for Multiple Spanning Tree Protocol IEEE 802.1Q for VLAN IEEE802.1p for CoS IEEE 802.1X for 802.1X Authentication IEEE 802.1AB for LLDP ITU-T G.8032 for ERPS</p>
Management	<p>SNMP v1/v2 c/v3, RMON, LLDP, DHCP Server, DHCP Snooping, Modbus TCP monitoring, IEC61850 MMS, QoS, Port settings, dynamic/static MAC address, MAC/IPv4, log reporting</p>
Security	<p>User permission classification, MAC security, AAA, 802.1X authentication, Radius, TACACS+, MAC Based authentication, storm control, SSH/HTTPS protocol authorization, link oscillation protection, port loop detection, access control, SNMP, RMON, Smart-Link, Port alarm, temperature alarm, power alarm, network load alarm</p>
Switch Function	<p>802.1Q VLAN, link aggregation, flow control</p>
Unicast / Multicast	<p>Multicast filtering, IGMP Snooping</p>
Redundancy	<p>STP/RSTP/MSTP, ERPS, Ring, MRP</p>

Technology

Troubleshooting	Log record, port mirroring, Ping, Traceroute, network cable diagnosis, SFP DDM
-----------------	--------------------------------------------------------------------------------

Time Management	NTP, PTP
-----------------	----------

Interface	Gigabit SFP: 100/1000Base-X SFP slot, 100M/Gigabit self-adaption (G1-G24), Gigabit (G25-G28) Console port: CLI command line management port (RS-232), RJ45 Alarm port: support 1 relay alarm output, adopt 3-pin 5.08mm pitch terminal blocks, current carrying capacity is 2A@250VAC or 2A@220VDC
-----------	----------------------------------------------------------------------------------------------------------------------------------------------------------------------------------------------------------------------------------------------------------------------------------------------------------

Indicator	Running Indicator, Alarm Indicator, Power Supply Indicator, Interface Indicator
-----------	---------------------------------------------------------------------------------

Switch Property	Transmission mode: store and forward MAC address: 32K Cache: 32Mbit Backplane bandwidth: 90Gbps Switch time delay: <10 μ s
-----------------	--------------------------------------------------------------------------------------------------------------------------------------------

Power Supply	Adopt 5-pin 5.08mm pitch terminal blocks <ul style="list-style-type: none">DC Product 2 24/48VDC (18-72VDC), dual power supply redundancy, support anti-reverse connectionAC product 2 110/220VAC/DC (85-264VAC/77-300VDC), dual power supply redundancy
--------------	-----------------------------------------------------------------------------------------------------------------------------------------------------------------------------------------------------------------------------------------------------------------------------------------

Working Environment	Operating temperature: -40~85 $^{\circ}$ C Storage temperature: -40~85 $^{\circ}$ C Relative humidity: 5%~95% (no condensation)
---------------------	---------------------------------------------------------------------------------------------------------------------------------------

Power Consumption	Model	No-load	Full-load
	MES5300-28GS-2LV	18.5W@48VDC	36.2W@48VDC
	MES5300-28GS-2HV	17.6W@220VAC	40.7W@220VAC

Mechanical Structure	Housing: IP40 protection, metal Installation: 19-inch 1U rack mounting Dimension (W x H x D): 491.6mm×44.45mm×290mm
----------------------	---------------------------------------------------------------------------------------------------------------------------

	<p>Weight:</p> <p>MES5300-28GS-2LV: 5.125kg</p> <p>MES5300-28GS-2HV: 5.387kg</p>
--	----------------------------------------------------------------------------------

Industrial Standard

IEC 61000-4-2 (ESD, electronic static discharge), Level 4

- Air discharge: ± 15kV
- Contact discharge: ±8kV

IEC 61000-4-4 (EFT, electrical fast transient pulses), Level 4

- Power supply: ±4kV
- Relay: ±4kV

IEC 61000-4-5 (Surge), Level 4

- Power supply: common mode ±4kV, differential mode ±2kV
- Relay: common mode ±4kV, differential mode ±2kV

Shock: IEC 60068-2-27

Free fall: IEC 60068-2-32

Vibration: IEC 60068-2-6

Authentication	CE, FCC, RoHS, IEC 61850-3 (in authentication), IEEE 1613 (in authentication)
-----------------------	-------------------------------------------------------------------------------

Warranty 5 years

Ordering Information

Model	Gigabit SFP Slot	Power Supply
MES5300-28GS-2LV-N	28	2 24/48VDC (18-72VDC) dual power supply redundancy and anti-reverse connection
MES5300-28GS-2HV-N	28	2 110/220VAC/DC (85-264VAC/77-300VDC) dual power supply redundancy