



MES5200 Series

19-inch 1U Rack Mounting

28-port 100M/Gigabit Layer 2 Managed Industrial Ethernet Switch

- Support 16 Gigabit copper ports, 8 100M fiber ports and 4 Gigabit SFP slots
- Support MRP ring network, reconfiguration time < 200ms
- Support multiple network protocols and industrial standards, such as ARP, STP/RSTP/MSTP, ERPS, VLAN, LACP, IGMP Snooping, LLDP, SNMP, etc., support Modbus TCP monitoring instruction of electricity SCADA system
- DC product supports 2 24/48VDC (18-72VDC), dual power supply redundancy, support anti-reverse connection
- AC product supports 2 110/ 220VAC/DC(85-264VAC/77-300VDC), dual power supply redundancy
- Support -40~85°C wide temperature operation, support level 4 electromagnetic compatibility protection, and conform to IEC 61850-3 and IEEE 1613 (substation) standards



Introduction

MES5200 series products are 28-port 100M/Gigabit layer 2 managed industrial Ethernet switches. This series provides 100M fiber port, Gigabit copper port and Gigabit SFP slot, and adopts standard rack installation method, which is specially designed for extremely severe electromagnetic interference environment to meet the anti-interference requirements of power monitoring industry.

Network management system supports a variety of network protocols and industry standards, such as ARP, IPv4, Ring, MRP, VLAN, STP/RSTP/MSTP, ERPS, LLDP, IGMP Snooping, Modbus TCP, QoS, port trunking, port mirroring, etc. It has perfect management functions, supporting port configuration, port statistics, ACL, 802.1X authentication, network diagnosis, rapid configuration, online upgrade, etc. CLI, WEB, Telnet, SNMP, SSH and other access methods can be supported. Network management system could bring you great user experience through its friendly interface design and easy and convenient operation.

The input power supply is two independent power supply circuits which can ensure the normal operation of the device when one power supply fails. The design of DIP switch could implement device factory setting recovery and restart. When power supply or port has link failure, ALARM indicator will be bright and send out alarm, meanwhile, alarm device connected to the relay will send out alarm for rapid scene troubleshooting. The hardware adopts fanless, low power consumption and wide temperature and voltage design, which has passed rigorous industrial standard tests, and suits the industrial scene environment with harsh requirements for EMC. It can be widely used in smart substation, smart grid, energy storage, photovoltaic, wind electricity, non-electric industry SCADA system and other industrial fields.

Features and Benefits

- ⦿ SNMPv1/v2c/v3 is used for network management of various levels
- ⦿ RMON can be used for efficient and flexible network monitoring
- ⦿ Port mirroring can conduct data analysis and monitoring, which is convenient for online debugging
- ⦿ QoS supports real-time traffic classification and priority setting
- ⦿ LLDP can achieve automatic topology discovery, which is convenient for visual management
- ⦿ File management is convenient for rapid configuration and online upgrading of the device
- ⦿ Log management records Console log, RAM log and Flash log
- ⦿ Bandwidth management can reasonably distribute network bandwidth, preventing unpredictable network status
- ⦿ Port statistics can be used for the port real time traffic statistics

- User password can conduct user hierarchical management to improve the device management security
- ACL can enhance network flexibility and security
- Relay alarm is convenient for troubleshooting of construction site
- Storm suppression can restrain broadcast, unknown multicast and unicast
- TELNET configuration and SSH configuration guarantee secure access to data
- Port Trunking can increase network bandwidth and enhance the reliability of network connection to achieve optimum bandwidth utilization
- IGMP Snooping and static multicast can be used to filter multicast data to save network bandwidth
- STP/RSTP/MSTP/Ring/MRP could implement network redundancy and prevent network storm
- ARP could be used for MAC address resolution
- With high reliability and stability, ERPS could avoid broadcast storm caused by data loopback
- Network diagnosis and troubleshooting could be conducted via Ping, Traceroute, Cable Diagnosis, SFP Digital Diagnosis

Dimension

Unit: mm

- MES5200-16GT8F4GS-2LV

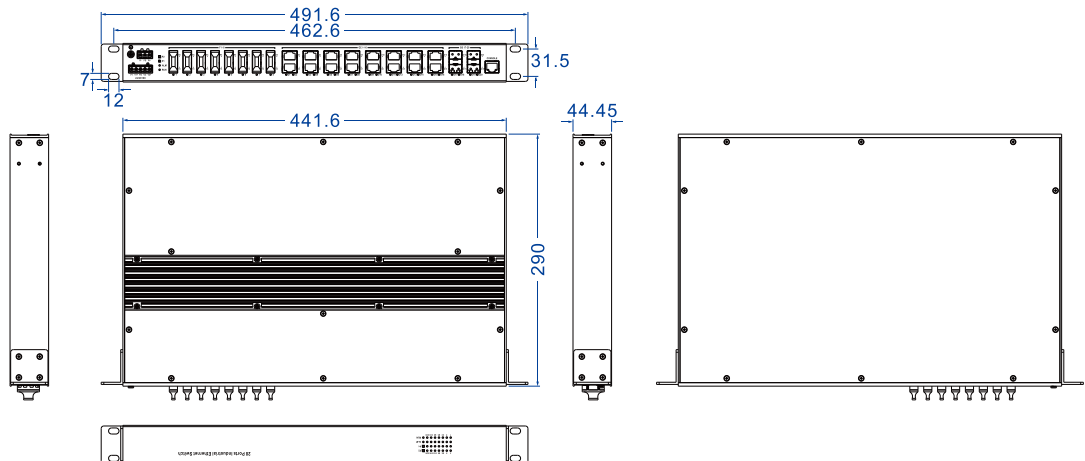

● MES5200-16GT8F4GS-2HV

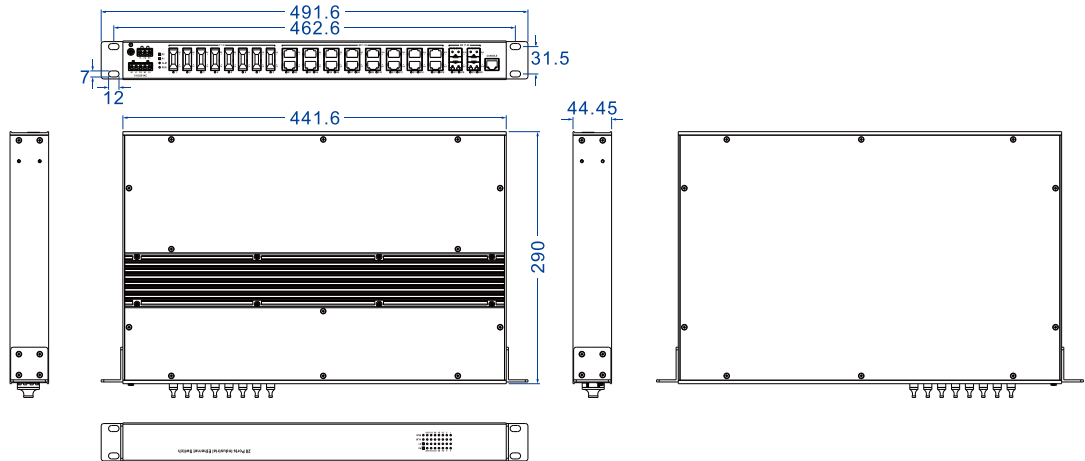

Specification

<p>Standard & Protocol</p>	<p>IEEE 802.3 for 10Base-T IEEE 802.3u for 100Base-FX IEEE 802.3z for 1000Base-X IEEE 802.3ab for 1000Base-T IEEE 802.3x for Flow Control IEEE 802.1D for Spanning Tree Protocol IEEE 802.1w for Rapid Spanning Tree Protocol IEEE 802.1s for Multiple Spanning Tree Protocol IEEE 802.1Q for VLAN IEEE802.1p for CoS IEEE 802.1X for 802.1X Authentication IEEE 802.1AB for LLDP ITU-T G.8032 for ERPS</p>
<p>Management</p>	<p>SNMP v1/v2c/v3, RMON, LLDP, QoS, port settings, dynamic/static MAC address, MAC/IPV4, log report</p>
<p>Security</p>	<p>Classification of User Permissions, Port and Power Alarm, MAC Security, Port Security, AAA, 802.1X Authentication, RADIUS, TACACS+, MAC-Based Authentication, Storm Control</p>
<p>Switch Function</p>	<p>802.1Q VLAN, link aggregation, flow control</p>
<p>Unicast / Multicast</p>	<p>Multicast filtering, IGMP Snooping</p>
<p>Redundancy Technology</p>	<p>STP/RSTP/MSTP, ERPS, Ring, MRP</p>

Troubleshooting	Log record, port mirroring, Ping, Traceroute, network cable diagnosis, SFP DDM
-----------------	--

Time Management	NTP
-----------------	-----

Interface	<p>Gigabit copper port: 10/100/1000Base-T(X) self-adaption, RJ45, Automatic Flow Control, Full/Half Duplex Mode, MDI/MDI-X Autotuning</p> <p>100M fiber port: 100Base-FX</p> <p>Gigabit SFP: 1000Base-X SFP slot, support forced 100M</p> <p>Console port: CLI command line management port(RS-232), RJ45</p> <p>Alarm port: support 1 relay alarm output, adopt 3-pin 5.08mm pitch terminal blocks, current carrying capacity is 2A@250VAC or 2A@220VDC</p>
-----------	--

Indicator	Running Indicator, Alarm Indicator, Power Supply Indicator, Interface Indicator
-----------	---

Switch property	<ul style="list-style-type: none"> ● Transmission mode: store and forward ● MAC address: 8K ● Buffer: 4.1Mbit ● Backplane bandwidth: 56Gbps ● Switch time delay: <10μs
-----------------	--

Power Supply	<p>Adopt 5-pin 5.08mm pitch terminal blocks</p> <ul style="list-style-type: none"> ● DC Product 2 24/48VDC (18-72VDC), dual power supply redundancy, support anti-reverse connection ● AC product 2 110/220VAC/DC (85-264VAC/77-300VDC), dual power supply redundancy
--------------	---

Power Consumption	Available Models	No-load	Full-load
	MES5200-16GT8F4GS-2HV	16.8W@220VAC	28.3W@220VAC

Working Environment	<p>Operating temperature: -40~85°C</p> <p>Storage temperature:-40~85°C</p> <p>Relative humidity: 5%~95% (no condensation)</p>
---------------------	---

Mechanical Structure	<p>Housing: IP40 protection, metal</p> <p>Installation: 19-inch 1U rack mounting</p> <p>Dimension (W x H x D): 491.6mm×44.45mm×290mm</p> <p>Weight: 5.292kg</p>
----------------------	---

Industrial Standard

IEC 61000-4-2 (ESD, electronic static discharge), Level 4

- Air discharge: $\pm 15\text{kV}$
- Contact discharge: $\pm 8\text{kV}$

IEC 61000-4-4 (EFT, electrical fast transient pulses), Level 4

- Power supply: $\pm 4\text{kV}$
- Relay: $\pm 4\text{kV}$
- Ethernet interface: $\pm 2\text{kV}$

IEC 61000-4-5 (Surge), Level 4

- Power supply: common mode $\pm 4\text{kV}$, differential mode $\pm 2\text{kV}$
- Relay: common mode $\pm 4\text{kV}$, differential mode $\pm 2\text{kV}$
- Ethernet interface: $\pm 4\text{kV}$

Shock: IEC 60068-2-27

Free fall: IEC 60068-2-32

Vibration: IEC 60068-2-6

Authentication

CE, FCC, RoHS, IEC 61850-3 (during authentication), IEEE 1613 (during authentication)

Warranty

5 years

Ordering Information

Available Models	Gigabit Copper Port	100M Fiber Port	Gigabit SFP Slot	Power Supply
MES5200-16GT8F4GS-2LV-N	16	8	4	2 24/48VDC(18-72VDC) Dual power supply redundancy
MES5200-16GT8F4GS-2HV-N	16	8	4	2 110/220VAC/DC (85-264VAC/77-300VDC) Dual power supply redundancy