



IES6300TSN-8GT2GS-2LV

DIN-Rail Mounting

10-Port Gigabit Layer 2 Managed Industrial Ethernet Switch

- Support 8 Gigabit copper ports and 2 Gigabit SFP slots
- Support Precision Time Protocol (PTP), provide sub-microsecond synchronization accuracy to meet requirements for high-precision time synchronization
- Support TSN (time sensitive networking) protocol standards such as IEEE802.1Qbv, IEEE802.1Qav and IEEE802.1AS, which can provide deterministic transmission with low delay and high reliability for data
- Adopt SW-Ring patented technology, support single ring, coupling ring, chain, Dual-homing, automatic recovery time of network failure < 20ms
- Support dual power supply, input voltage: 9~60VDC
- Support -40~75°C wide operating temperature range



Introduction

IES6300TSN-8GT2GS-2LV is 10-port Gigabit layer 2 managed industrial Ethernet switch. This product provides Gigabit copper ports and Gigabit SFP slots, and it adopts DIN-Rail mounting which can meet the requirements of different scenes.

Network management system supports various network protocols and industrial standards, such as PTP, TSN, STP/RSTP/MSTP, ERPS, 802.1Q VLAN, QoS, IGMP Snooping, LLDP, DHCP Server, DHCP-Snooping, Port Trunking, Port Mirroring. It also possesses complete management functions, including Port Configuration, Port Isolation, Port Statistics, Access Control, Network Diagnosis, Rapid Configuration, Online Upgrading and so on, and supports CLI, WEB, Telnet, SSH, SNMP and other access methods. Network management system could bring you great user experience through its friendly interface design and easy and convenient operation.

The design of DIP switch could implement device factory setting recovery. The input power supply is two independent power supply circuits which can ensure the normal operation of the device when one power supply fails. When power supply, port or other configurable event has failure or alarm, ALM indicator will be bright and send out alarm, meanwhile, alarm device connected to the relay will send out alarm for rapid scene troubleshooting. Hardware adopts fanless, low power consumption, wide temperature and voltage design and has passed rigorous industrial standard tests, which can suit for the industrial scene environment with harsh requirements for EMC. It can be widely used in smart city, rail transit, smart city, safety city, new energy, intelligent manufacturing and other industrial fields.

Features and Benefits

- ⊙ SNMPv1/v2c/v3 is used for network management of various levels
- ⊙ Port mirroring can conduct data analysis and monitoring, which is convenient for online debugging
- ⊙ Support static manual configuration and dynamically DHCP assignment IP address
- ⊙ NTP server and NTP client can provide time synchronization with millisecond precision
- ⊙ QoS supports multiple modes based on CoS and DSCP, and supports traffic policies of SP and WRR
- ⊙ LLDP can achieve automatic topology discovery, which is convenient for visual management
- ⊙ DHCP server can be used for distributing IP address with different strategies
- ⊙ DHCP Snooping can ensure DHCP client gets IP address from legal DHCP server
- ⊙ File management is convenient for the device rapid configuration and online upgrading
- ⊙ Log information records startup, operation, connection and alarm information, which can be uploaded to the remote Syslog server
- ⊙ Port ingress rate limit, which can divide CoS priority and reasonably control data

- bandwidth according to bandwidth, protocol, storm or custom data protocol type
- ⊙ Port statistics can be used for port real-time traffic statistics, displaying real-time network utilization in graph and detecting network performance
- ⊙ User password can conduct user hierarchical management to improve the device management security
- ⊙ Support port, temperature, voltage, network load, packet loss, error and other alarm events, SNMP Trap, relay, e-mail and other alarm modes, which is convenient for discovering faults in time during remote management.
- ⊙ Access Control can enhance network flexibility and security
- ⊙ Relay alarm is convenient for troubleshooting of construction site
- ⊙ SSH configuration could encrypt transmitted data, prevent DNS and IP spoofing
- ⊙ VLAN is used for simplifying network planning
- ⊙ Port isolation could achieve port isolation in the same VLAN and save VLAN resources
- ⊙ Port Trunking and LACP can increase network bandwidth and enhance the reliability of network connection to achieve optimum bandwidth utilization
- ⊙ IGMP Snooping and static multicast can be used to filter multicast data to save network bandwidth
- ⊙ With high reliability and stability, ERPS could avoid broadcast storm caused by data loopback
- ⊙ Ring and STP/RSTP/MSTP can achieve network redundancy, preventing network storm
- ⊙ Loop detection could efficiently eliminate the influence caused by port loopback by detecting the existence of loopback
- ⊙ Ping, Traceroute, Cable Test and SFP Digital Diagnosis could achieve network diagnosis and troubleshooting

Dimension

Unit: mm

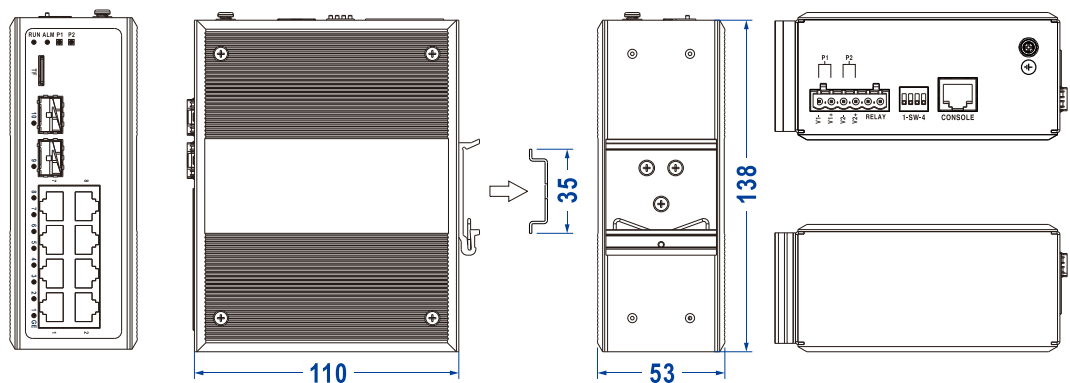

Specification

<p>Standard & Protocol</p>	<p>IEEE 802.3 for 10Base-T IEEE 802.3u for 100Base-TX IEEE 802.3ab for 1000Base-T IEEE 802.3z for 1000Base-X IEEE 802.3x for Flow Control IEEE 802.1D for Spanning Tree Protocol IEEE 802.1w for Rapid Spanning Tree Protocol IEEE 802.1s for Multiple Spanning Tree Protocol IEEE 802.1Q for VLAN IEEE 802.1p for CoS IEEE 802.1AB for LLDP IEEE 802.3ad for LACP IEEE 1588 for PTP IEEE 802.1AS for gPTP IEEE802.1Qbv, IEEE 802.1Qav for TSN</p>
<p>Management</p>	<p>SNMP v1/v2c/v3 Centralized Management of Equipment, DHCP Server, Port Mirroring(TX,RX,TX&RX), QoS, LLDP, File Management, Log Management, Syslog Server, Port Statistics</p>
<p>Security</p>	<p>Classification of User Permissions, Access Control, Port Alarm, Temperature Alarm, Power Supply Alarm, Network Load Alarm, Error Frame Alarm, Discarded Frame Alarm, Trap Alarm, Relay Alarm, E-mail Alarm, SSH Configuration, Telnet Configuration, HTTP Configuration, HTTPS Configuration, DHCP-Snooping, Loop Detection</p>
<p>Switch Function</p>	<p>802.1Q VLAN, Port Static/Dynamic Aggregation, Bandwidth Management, Flow Control, Port Rate Limit, Port Isolation</p>
<p>Redundancy Technology</p>	<p>Ring, STP/RSTP/MSTP, ERPS</p>
<p>Troubleshooting</p>	<p>Ping, Traceroute, Cable Diagnosis, SFP DDM</p>
<p>Time Management</p>	<p>NTP server, NTP client, PTP, TSN</p>
<p>Interface</p>	<p>Gigabit copper port: self-adaptive 10/100/1000Base-T(X) RJ45, Automatic Flow Control, Full/Half Duplex Mode, MDI/MDI-X Autotuning</p> <p>Gigabit SFP: 1000Base-X SFP slot</p> <p>TF card slot (reserved): 1 TF(Micro SD) card slot, reserved</p> <p>Alarm port: 1 relay alarm output, 6-pin 5.08mm pitch terminal blocks, relay occupies the right 2 pins, current carrying capacity is 1A@30VDC or 0.3A@125VAC</p> <p>Console port: CLI command line management port(RS-232), RJ45</p>

Indicator	RUN indicator, ALM indicator, power supply indicator, interface indicator
Switch Property	Transmission mode: store and forward MAC address: 16K Buffer: 2Mbit Backplane bandwidth: 20G Switch time delay: <10μs
Power Supply	9~60VDC, support dual power supply redundancy, non-polarity, using 6-pin 5.08mm pitch terminals (the power supply occupies the left 4 pins)
Power Consumption	No-load: 4.3W@48VDC (normal temperature), 4.9W@48VDC (high temperature) Full-load: 6.8W@48VDC (normal temperature), 7.8W@48VDC (high temperature)
Working Environment	Operating temperature: -40~75°C Storage temperature: -40~85°C Relative humidity: 5%~95% (no condensation)
Physical Characteristic	Housing: IP40 protection, metal Installation: DIN-Rail mounting Dimension (W x H x D): 53mm×138mm×110mm Weight: 0.6kg
Industrial Standard	IEC 61000-4-2 (ESD, electrostatic discharge), Level 3 <ul style="list-style-type: none"> Air discharge: ±8kV Contact discharge: ±6kV IEC 61000-4-4 (EFT, electrical fast transient), Level 3 <ul style="list-style-type: none"> Power supply: ±2kV Signal: ±1kV IEC 61000-4-5 (Surge), Level 3 <ul style="list-style-type: none"> Power supply: differential mode ±1kV, common mode ±2kV Signal: differential mode ±1kV, common mode ±2kV Shock: IEC 60068-2-27 Free fall: IEC 60068-2-32 Vibration: IEC 60068-2-6
Authentication	CE, FCC, RoHS



Warranty	5 years
----------	---------

Ordering Information

Available Models	Gigabit Copper Port	Gigabit SFP Slot	Power Supply
IES6300TSN-8GT2GS-2LV-N	8	2	9~60VDC redundant power supply