



IES6300-8GHP2GS2HS-2P48-360W

DIN-Rail Mounting

12-Port Gigabit Layer 2 Managed Industrial PoE++ Ethernet Switch

- Support 2 100M/1G/2.5G SFP slots, 2 100M/1G SFP slots, 8 Gigabit PoE port, 2 DI and 2 DO
- All PoE ports conform to IEEE 802.3af/at/bt standard. Single PoE port supports up to 90W power and the total power of PoE ports supports up to 360W
- Adopt patented Ring technology, support single ring, coupling ring, chain, Dual-homing, automatic recovery time of network failure < 20ms
- Support multiple network protocols and industry standards, such as STP/RSTP/MSTP, ERPS, PoE, DHCP, VLAN, QoS, IGMP Snooping, LLDP, ACL and SNMP.
- Support dual power redundancy, input voltage 50~55VDC
- Support -40~75°C wide operating temperature range



Introduction

IES6300-8GHP2GS2HS-2P48-360W is 12-port Gigabit layer 2 managed industrial PoE Ethernet switch. PoE power supply conforms to IEEE802.3af/at/bt protocol standard. This product provides multiple interfaces including Gigabit PoE copper ports, 100M/1G SFP slots, 100M/1G/2.5G SFP slots and I/O ports. It adopts DIN-Rail mounting to meet the requirements of different application scenes.

The network management system supports a variety of network protocols and industry standards, such as Ring, STP/RSTP/MSTP, ERPS, DHCP Server/Snooping/Relay, VLAN, QoS, IGMP Snooping, LLDP, MEP, LACP and Port Mirroring. It possesses complete management functions and supports Port Configuration, NAS, ACL, Network Diagnosis, Online Upgrade, etc. CLI, WEB, TELNET, SSH, SNMP and other access methods can be supported. It can provide users with good experience with friendly design of network management system interface, simple and convenient operation.

The power supply has two independent power supply circuits which can ensure the normal operation of the device when one power supply fails. The design of DIP switch could implement device factory setting recovery. When DC power supply or port has link failure, ALM indicator will be bright and send out alarm, meanwhile, alarm device connected to the relay will send out alarm for rapid scene troubleshooting. The hardware adopts fanless, low power consumption and wide temperature design, which has passed rigorous industrial standard tests, and suits for the industrial scene environment with harsh requirements for EMC. It can be widely used in AP coverage, railway transportation, smart city, safe city, new energy, smart grid, intelligent manufacturing and other industrial fields.

Features and Benefits

- ⦿ SNMPv1/v2c/v3 is used for network management of various levels
- ⦿ RMON can be used for efficient and flexible network monitoring
- ⦿ QoS supports real-time traffic classification and priority setting
- ⦿ LLDP can achieve automatic topology discovery, which is convenient for visual management
- ⦿ DHCP server and DHCP client could be used for allocating IP address of different strategies
- ⦿ DHCP Snooping can ensure DHCP client gets IP address from legal DHCP server
- ⦿ DHCP relay function can realize IP address, gateway, DNS configuration cross network segment
- ⦿ File management is convenient for the device rapid configuration and online upgrading
- ⦿ Alarm log and log server can record user operation, system failure, system security and other information locally and remotely
- ⦿ User privilege classification configuration can set user privilege level
- ⦿ SSH configuration and HTTPS configuration can improve device's management

- security and guarantee data access security
- Support NAS network access service and provide security assurance for multiple services
- MEP function can determine the scope and boundary of maintenance domain
- EVC configuration function can realize the connection between the two points of Ethernet service
- Ring and STP/RSTP/MSTP can achieve network redundancy, preventing network storm
- EPRS function can realize link backup and improve the reliability of network
- Relay alarm is convenient for troubleshooting of construction site
- Storm suppression can restrain broadcast, unknown multicast and unicast
- VLAN is used for simplifying network planning
- Port trunking and LACP can increase network bandwidth and enhance the reliability of network connection to achieve optimum bandwidth utilization
- IGMP Snooping can be used for filtering multicast traffic to save the network bandwidth
- PoE could power device over Ethernet, thus decreasing the cable connection of powered devices
- Support I/O port input and output, I/O status alarm and control remote device
- Network diagnosis and troubleshooting could be conducted via Ping and cable detection
- Port mirroring can conduct data analysis and monitoring, which is convenient for online debugging
- Support both active and standby systems. If the main system fails during system startup, the standby system can be started automatically
- Support 20s quick start of device power system

Dimension

Unit: mm

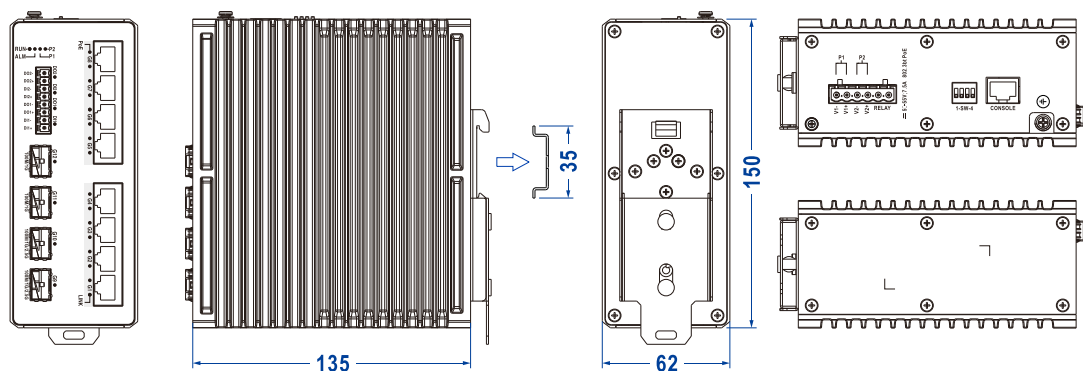

Specification

Standard & Protocol	<p>IEEE 802.3 for 10Base-T IEEE 802.3u for 100Base-TX IEEE 802.3ab for 1000Base-T IEEE 802.3z for 1000Base-X IEEE 802.3x for Flow Control IEEE 802.1D for Spanning Tree Protocol IEEE 802.1w for Rapid Spanning Tree Protocol IEEE 802.1s for Multiple Spanning Tree Protocol ITU-T G.8032 for ERPS IEEE 802.1Q for VLAN IEEE 802.1p for CoS IEEE 802.1AB for LLDP IEEE 802.3ad for LACP IEEE 802.3af for PoE IEEE 802.3at for PoE+ IEEE 802.3bt for PoE++</p>
Management	<p>SNMP v1/v2c/v3 Centralized Management of Equipment, QoS, PoE, DHCP Server, DHCP Snooping, DHCP Relay, Static MAC Address, LLDP, Storm Suppression, User Password, Login Method, File Management, Log Management, Port Statistics, MEP</p>
Security	<p>User Privilege Classification, Authentication Method Configuration, SSH Configuration, HTTPS Configuration, Access Control, SNMP, RMON, Port Limit Control, Port Security, NAS, ACL, Ethernet Services, RADIUS Server Authentication, TACACS + Server Authentication, Port Alarm, DC Power Supply Alarm, IO Alarm, Loop Protection</p>
Switch Function	<p>802.1Q VLAN, Static Aggregation, LACP</p>
Unicast / Multicast	<p>IGMP Snooping, Unicast MAC</p>
Redundancy Technology	<p>Ring, STP/RSTP/MSTP, ERPS</p>
Troubleshooting	<p>Ping, Cable Detection, Port Mirroring</p>
Time Management	<p>NTP, Time Zone Configuration</p>
PoE	<p>The total power of PoE supports 360W and supports the mixed plug-in of devices of IEEE 802.3af, IEEE 802.3at and IEEE 802.3bt standards PoE supports enabling and disabling port power supply PoE supports power supply priority. When the power is overloaded, it can power high priority device first PoE supports delayed power supply to avoid the instant power supply shock when powering on the device</p>

	PoE supports detecting the status of power receiving devices automatically. When the power receiving device fails, the power supply port can be closed and reopened to restart the power receiving device and solve the problem of power receiving device crash
--	---

Interface

Gigabit PoE port: 10/100/1000Base-T(X) self-adaption, RJ45, Full/Half Duplex, MDI/ MDI-X self-adaption. The single port supports 15.4W PoE output power of IEEE802.3af standard and 30W PoE+ output power of IEEE802.3at standard, power supply pin: 1/2-, 3/6+; 90W PoE++ output power of IEEE802.3bt standard, power supply pin: 1/2-, 3/6+, 4/5-, 7/8+

Gigabit SFP Slot: 100/1000Base-X self-adaption or forced mode, SFP slot

2.5G SFP Slot: 100/1000/2.5G Base-X self-adaption or forced mode, SFP slot

I/O port: Support 2 DI and 2 DO, 8-pin 3.81mm pitch terminal blocks, support dry contact input and relay-type output

Console port: CLI command line management port(RS-232), RJ45

Alarm port: 6-pin 5.08mm pitch terminal blocks (relay occupies 2 pins), support 1 relay alarm output, the current load capacity is 1A@30VDC or 0.3A@125VAC

Indicator	Running indicator, alarm indicator, power supply indicator, interface indicator, PoE indicator, I/O output indicator, I/O input indicator
------------------	---

Switch Property

Transmission mode: store and forward
 MAC address: 8K
 Packet buffer size: 4Mbit
 Backplane bandwidth: 30G
 Switch delay: <10μs

Power Supply	Power input: 50~ 55VDC Connection method: 6-pin 5.08mm pitch terminal blocks (includes 4-pin power supply) Power supply quantity: dual power supply redundancy backup Connection protection: anti-reverse connection Overcurrent protection: 7.5A
---------------------	---

Power Consumption

No-load: ≤ 5.5W@50VDC
 Full-load: ≤ 380W@50VDC (with 360W PoE load)

Working Environment	Operating temperature: -40~75°C Storage temperature: -40~85°C
----------------------------	--

	Relative humidity: 5%~95% (no condensation)
Physical Characteristic	Housing: IP40 protection, metal Installation: DIN-Rail mounting Dimension (W x H x D): 62mm×150mm×135mm
Industrial Standard	IEC 6100042 (ESD, electrostatic discharge), Level 3 IEC 6100044 (EFT, electrical fast transient pulses), Level 3 IEC 61000-4-5 (Surge), Level 3 Shock: IEC 60068-2-27 Free fall: IEC 60068-2-32 Vibration: IEC 60068-2-6
Authentication	CE, FCC, RoHS
Warranty	5 years

Ordering Information

Available Models	10M/100M/1G PoE++ RJ45	100M/1G SFP	100M/1G/2.5G SFP	DI	DO	Power Consumption	Power Supply
IES6300-8GHP2G S2HS-2P48-360W -N	8	2	2	2	2	360W	50~55VDC Redundant power supply