



## IES6000-4GT2HS

DIN-Rail Mounting

6-Port Gigabit Layer 2 Managed Industrial Ethernet Switch

- Support 2 2.5G Ethernet SFP fiber ports and 4 Gigabit copper ports
- Adopt Ring patented technology, support single ring, coupling ring, chain, Dual-homing, automatic recovery time of network failure < 20ms
- Support multiple network protocols and industrial standard, such as STP/RSTP/MSTP, ERPS, DHCP, VLAN, QoS function, IGMP Snooping function, LLDP etc.
- Support dual power redundancy, input voltage 12~48VDC
- Support -40~75°C wide operating temperature range



Industrial Grade



RPS





# Introduction

---

IES6000-4GT2HS are 6-port Gigabit layer 2 managed industrial Ethernet switches. This product provides 4 Gigabit copper ports and 2 2.5G SFP slots, and it adopts DIN-Rail mounting which can meet the requirements of different scenes.

Network management system supports various network protocols and industrial standards, such as Ring, STP/ RSTP/MSTP, ERPS, DHCP, VLAN, QoS function, IGMP Snooping, LLDP, Port Trunking, Port Mirroring, etc. It also possesses complete management functions, including Port Configuration, Access Control, Network Diagnosis, Online Upgrading and so on, and supports CLI, WEB, Telnet, SSH, SNMP and other access methods. It can provide users with good experience with friendly design of network management system interface, simple and convenient operation.

The product provides two independent power supply circuits, which can ensure the normal operation of the device when one power supply fails. The design of DIP switch could implement device factory setting recovery. When DC power supply or port has link failure, ALM indicator will be bright and send out alarm, meanwhile, alarm device connected to the relay will send out alarm for rapid scene troubleshooting. The hardware adopts fanless, low power consumption and wide temperature and voltage design, which has passed rigorous industrial standard tests, and suits for the industrial scene environment with harsh requirements for EMC. It can be widely used in AP coverage, railway transportation, smart city, safe city, new energy, smart grid, aerospace, intelligent manufacturing, military project and other industrial fields.

## Features and Benefits

---

- ⊙ SNMPv1/v2c/v3 is used for network management of various levels
- ⊙ RMON can be used for efficient and flexible network monitoring
- ⊙ QoS supports real-time traffic classification and priority setting
- ⊙ LLDP can achieve automatic topology discovery, which is convenient for visual management
- ⊙ DHCP server can be used for distributing IP address with different strategies
- ⊙ DHCP Snooping can ensure DHCP client gets IP address from legal DHCP server
- ⊙ DHCP relay function can realize IP address, gateway, DNS configuration cross network segment
- ⊙ File management is convenient for the device rapid configuration and online upgrading
- ⊙ User privilege classification configuration can set user privilege level
- ⊙ SSH configuration and HTTPS configuration can improve device's management security and guarantee data access security
- ⊙ Support NAS network access service and provide security assurance for multiple services
- ⊙ IPMC file configuration can deploy access control on IP multicast flow
- ⊙ MEP function can determine the scope and boundary of maintenance domain

- ⊙ Ring and STP/RSTP/MSTP can achieve network redundancy, preventing network storm
- ⊙ EPRS function can realize link backup and improve the reliability of network
- ⊙ Loop protection could efficiently eliminate the influence caused by port loopback
- ⊙ Relay alarm is convenient for troubleshooting of construction site
- ⊙ Storm suppression can restrain broadcast, unknown multicast and unicast
- ⊙ VLAN is used for simplifying network planning
- ⊙ Static Aggregation and LACP can increase network bandwidth and enhance the reliability of network connection to achieve the best bandwidth utilization
- ⊙ IGMP Snooping can be used for filtering multicast traffic to save the network bandwidth
- ⊙ Network diagnosis and troubleshooting could be conducted via Ping and cable detection
- ⊙ Port mirroring can conduct data analysis and monitoring, which is convenient for online debugging

## Dimension

Unit: mm

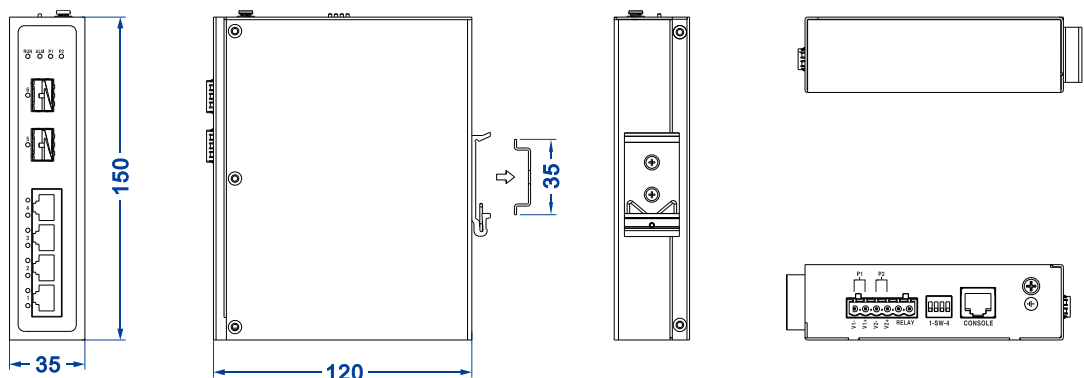

## Specification

### Standard & Protocol

IEEE 802.3 for 10Base-T  
 IEEE 802.3u for 100Base-TX  
 IEEE 802.3ab for 1000Base-T  
 IEEE 802.3z for 1000Base-X  
 IEEE 802.3x for Flow Control  
 IEEE 802.1D for Spanning Tree Protocol  
 IEEE 802.1w for Rapid Spanning Tree Protocol  
 IEEE 802.1s for Multiple Spanning Tree Protocol  
 ITU-T G.8032 for ERPS  
 IEEE 802.1Q for VLAN  
 IEEE 802.1p for CoS  
 IEEE 802.1AB for LLDP

	IEEE 802.3ad for LACP
<b>Management</b>	SNMP v1/v2c/v3 Centralized Management of Equipment, RMON, Port Mirroring, QoS, LLDP, DHCP Server, DHCP Snooping, DHCP relay, user password, login method, File Management, Log Management, Port Statistics
<b>Security</b>	User Privilege Classification, Authentication method Configuration, SSH Configuration, HTTPS Configuration, Access Management, SNMP, RMON, NAS, Radius Server Authentication, TACACS + Server Authentication, ACL, Port Alarm, DC Power Supply Alarm, Loop Protection
<b>Switch Function</b>	802.1Q VLAN, Static Aggregation, LACP
<b>Unicast / Multicast</b>	IGMP Snooping
<b>Redundancy Technology</b>	Ring, STP/RSTP/MSTP, ERPS
<b>Troubleshooting</b>	Ping, Cable Detection
<b>Time Management</b>	NTP, Time Zone Configuration
<b>Interface</b>	Gigabit copper port: 10/100/1000Base-T(X), RJ45, Automatic Flow Control, Full/Half Duplex, MDI/MDI-X Autotuning; 2.5G SFP Slot: 100/1000 Base-X self-adaption or 100/1000/2.5G Base-X forced mode, SFP slot Console port: CLI command line management port(RS-232), RJ45 Alarm Port: 6-Pin 5.08mm pitch terminal blocks, relay occupies 2 pins and 1 relay alarm information output is supported, the current load capability is 1A@30VDC or 0.3A@125VAC
<b>Indicator</b>	Running Indicator, Alarm Indicator, Power Supply Indicator, Interface Indicator
<b>Switch Property</b>	Transmission mode: store and forward MAC address: 8K Packet buffer size: 4Mbit Backplane bandwidth: 30G Switch time delay: <10μs
<b>Power Supply</b>	Power input: 12~ 48VDC Connection method: 6- Pin 5.08mm pitch terminal blocks (includes 4-pin power supply) Power supply quantity: dual power supply redundancy backup Connection protection: anti-reverse connection

Overcurrent protection: 5A

<b>Power Consumption</b>	No-load: 3.2W@24VDC Full-load: 6.6W@24VDC
--------------------------	--

**Working Environment**

Operating temperature: -40~75°C  
Storage temperature: -40~85°C  
Relative humidity: 5%~95% (no condensation)

<b>Physical Characteristic</b>	Housing: IP40 protection, metal Installation: DIN-Rail mounting Weight: 634g Dimension (W x H x D): 35mm×150mm×120mm
--------------------------------	---

**Industrial Standard**

IEC 6100042 (ESD, electrostatic discharge), Level 3

- Air discharge: ±8kV
- Contact discharge: ±6kV

IEC 6100044 (EFT, electrical fast transient pulses), Level 3

- Power supply: ±2kV
- Relay: ±2kV
- Signal: ±1kV

IEC 61000-4-5 (Surge), Level 3

- Power supply: differential mode±1kV, common mode±2kV
- Relay: differential mode±1kV, common mode±2kV
- Signal: differential mode±1kV, common mode±2kV

Shock: IEC 60068- 2- 27

Free fall: IEC 60068- 2- 32

Vibration: IEC 60068-2-6

<b>MTBF</b>	200, 000 hours
-------------	----------------

**Authentication** CE, FCC, RoHS

<b>Warranty</b>	5 years
-----------------	---------

## Ordering Information

Available Models	Gigabit Copper Port	2.5G SFP Slot	Power Supply
IES6000-4GT2HS-N	4	2	12~48VDC, dual power supply