

## IES2100SL Series

DIN-Rail Mounting

5/8/16-Port 100M Unmanaged Industrial Ethernet Switch

- Support 5, 8 or 16 100M copper ports (optional)
- Support storm suppression, flow control, one-key VLAN, CC-A and other functions
- Support up to 2048 bytes of Jumbo frame
- Support dual power redundancy, input voltage 12/24/48 VDC (9~60VDC)
- Support -40~75°C operating temperature range
- Support IP40 protection grade



# Introduction

IES2100SL series are 5/8/16-port 100M unmanaged industrial Ethernet switches. This series provide 3 products and support 100M copper ports. They adopt DIN-Rail mounting to meet the requirements of different application scenes.

DIP switch can implement functions such as the device storm suppression, flow control, VLAN, CC-A. The input power supply is two independent power supply circuits which can ensure the normal operation of the device when one power supply fails. Hardware adopts fanless, low power consumption, wide temperature and voltage design and has passed rigorous industrial standard tests, which can suit for the industrial scene environment with harsh requirements for EMC. It can be widely used in smart city, safety city, intelligent manufacturing and other industrial fields.

# Dimension

Unit: mm

- IES2100SL-5T-2LV

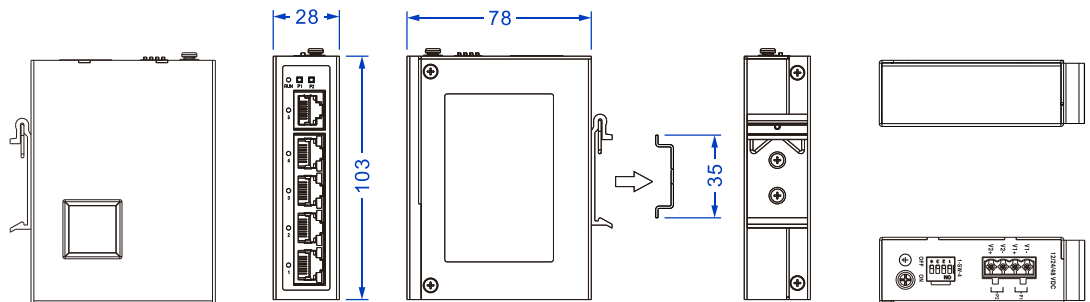

- IES2100SL-8T-2LV

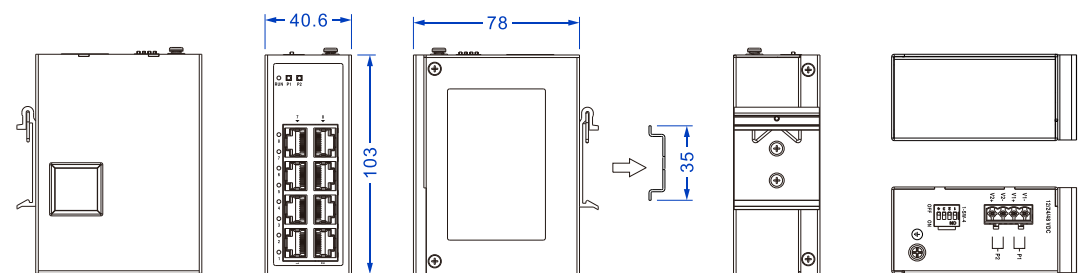

- IES2100SL-16T-2LV

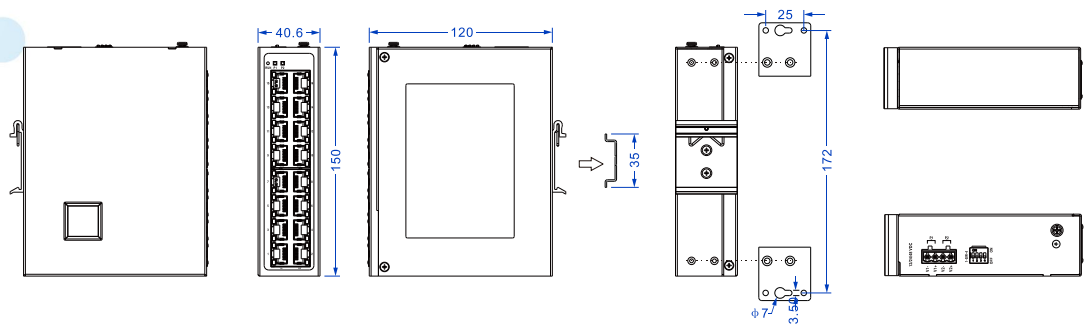

## Specification

<b>Standard &amp; Protocol</b>	IEEE 802.3 for 10Base-T IEEE 802.3u for 100Base-TX IEEE 802.3x for Flow Control IEEE 802.1Q for VLAN			
<b>Interface</b>	100M copper port: 10/100Base-T(X) self-adaptive RJ45, full/half duplex mode self-adaption, MDI/MDI-X autotuning DIP switch: 1-CC-A, 2-storm suppression, 3-VLAN, 4-flow control(5T/8T) 1-flow control, 2-storm suppression, 3-CC-A, 4-NC (16T)			
<b>Indicator</b>	Power indicator, running indicator, interface indicator			
<b>Switch Property</b>	Transmission mode: store and forward MAC address: 2K (5T/8T), 8K (16T) Backplane bandwidth: 1Gbps (5T), 1.6Gbps (8T) and 3.2Gbps (16T) Switch time delay: <10μs			
<b>Power Supply</b>	12/24/48 VDC (9~60VDC), dual power supply redundancy, using 4-pin 5.08mm pitch terminal blocks, support anti-reverse connection			
<b>Power Consumption</b>	<b>Model</b>	<b>No-load (25°C)</b>	<b>Full-load (25°C)</b>	<b>Full-load (75°C)</b>
	IES2100SL-5T-2LV	0.324W@12VDC	0.985W@12VDC	1.094W@12VDC
	IES2100SL-8T-2LV	0.288W@12VDC	1.12W@12VDC	1.29W@12VDC
	IES2100SL-16T-2LV	0.77W@48VDC	2.5W@48VDC	2.6W@48VDC
<b>Working Environment</b>	Operating temperature: -40~75°C Storage temperature: -40~85°C Relative humidity: 5%~95% (no condensation)			
<b>Mechanical Structure</b>	Housing: IP40 protection, metal Installation: DIN-Rail mounting Dimensions (W x H x D): 28mm×103mm×78mm (5T)			

40.6mm×103mm×78mm(8T)

40.6mm×150mm×120mm(16T)

Weight: 0.259kg(5T), 0.33kg(8T), 0.633kg(16T)

**Industrial  
Standard**

IEC 61000-4-2 (ESD, electrostatic discharge), Level 4

- Contact discharge: ±8kV
- Air discharge: ± 15kV

IEC 61000-4-4 (EFT, electrical fast transient), Level 4

- Power supply: ±4kV
- Copper port: ±2kV

IEC 61000-4-5 (Surge), Level 4

- Power supply: differential mode±2kV, common mode±4kV
- Copper port: ±2kV

Shock: IEC 60068-2-27

Free fall: IEC 60068-2-31

Vibration: IEC 60068-2-6

**Authentication** CE, FCC, RoHS

**Warranty** 5 years

## Ordering Information

Model	100M Copper Port	Power Supply
IES2100SL-5T-2LV-N	5	12/24/48 VDC Dual power supply redundancy
IES2100SL-8T-2LV-N	8	
IES2100SL-16T-2LV-N	16	