



ICS6400BT-8GP4XS-2LV

DIN-Rail Mounting

12-Port Gigabit/10Gigabit Layer 3 Industrial Ethernet Switch

- Support 8 Gigabit PoE copper ports, 4 10Gigabit SFP+ slots, and 1 USB interface
- Adopt Ring patented technology, support single ring, coupling ring, chain, Dual-homing ring network function, automatic recovery time of network failure < 50ms
- Support PoE power supply, with a maximum output power consumption of 90W for a single PoE port and a maximum output power of 360W for the entire machine
- Support 2 48VDC (44~57VDC), dual power redundancy, and anti-reverse connection
- Support -40~75°C wide operating temperature range



Industrial Grade



RPS

Introduction

ICS6400BT-8GP4XS-2LV is a 12-port Gigabit /10Gigabit layer 3 industrial Ethernet switch. PoE power supply conforms to IEEE802.3af/at/bt protocol standard, and it can power device over Ethernet, thus decreasing the cable connection of powered devices. This product provides Gigabit PoE copper ports and 10 Gigabit SFP+ slots, and it adopts DIN-Rail mounting which can meet the requirements of different scenes.

Network management system supports various network protocols and industrial standards, such as Static Routing, RIP, VRRP, NAT, STP/RSTP/MSTP, EPRS, 802.1Q VLAN, QoS, DHCP Server, DHCP Client, IGMP Static Multicast, LLDP, Port Trunking, Port Mirroring, etc. It also possesses complete management functions, including Port Configuration, Port Statistics, Access Control, 802.1X Authentication, Network Diagnosis, Rapid Configuration, Online Upgrading and so on; and supports CLI, HTTP, HTTPS, Telnet, SSH and other access methods., Network management system could bring you great user experience through its friendly interface design and easy and convenient operation.

The input power supply is two independent power supply circuits which can ensure the normal operation of the device when one power supply fails. The design of DIP switch could implement device factory setting recovery and restart. When power supply or port has link failure, ALM indicator will be bright and send out alarm, meanwhile, alarm device connected to the relay will send out alarm for rapid scene troubleshooting. Hardware adopts fanless, low power consumption, wide temperature and voltage design and has passed rigorous industrial standard tests, which can suit for the industrial scene environment with harsh requirements for EMC. It can be widely applied in industrial fields such as smart cities, security, parks, and electronic police.

Features and Benefits

- ⦿ SNMPv1/v2c/v3 is used for network management of various levels
- ⦿ RMON can be used for efficient and flexible network monitoring
- ⦿ QoS supports real-time traffic classification and priority setting
- ⦿ LLDP can achieve automatic topology discovery, which is convenient for visual management
- ⦿ DHCP server and DHCP client could be used for allocating IP address of different strategies
- ⦿ DHCP Snooping can ensure DHCP client gets IP address from legal DHCP server
- ⦿ DHCP relay function can realize IP address, gateway, DNS configuration cross network segment
- ⦿ File management is convenient for the device rapid configuration and online upgrading
- ⦿ Log information and log server can record user operation, system failure, system security and other information locally and remotely
- ⦿ User privilege classification configuration can set user privilege level

- 
- ⊙ ACL can enhance the flexibility and security of the network, supporting bidirectional ACL IN and OUT.
 - ⊙ Relay alarm is convenient for troubleshooting of construction site
 - ⊙ SSH configuration and HTTPS configuration can improve device's management security and guarantee data access security
 - ⊙ Ring, STP/ RSTP/ MSTP could implement network redundancy and prevent network storm
 - ⊙ EPRS function can realize link backup and improve the reliability of network
 - ⊙ Storm suppression can restrain broadcast, unknown multicast and unicast
 - ⊙ VLAN is used for simplifying network planning
 - ⊙ Port Trunking and LACP can increase network bandwidth and enhance the reliability of network connection to achieve optimum bandwidth utilization
 - ⊙ IGMP Snooping can be used for filtering multicast traffic to save the network bandwidth
 - ⊙ IGMP can be used to manage and maintain multicast members
 - ⊙ ARP can be used for MAC address resolution, user password can conduct user hierarchical management to improve the device management security
 - ⊙ VRRP, RIP, ISIS, OSPF, BGP can achieve dynamic routing configuration
 - ⊙ PIM-DM/PIM-SM/PIM-SSM can be used to create and maintain multicast routing table entries and realize multicast routing forwarding
 - ⊙ NAT maps private IP address to the legal IP address of external network, which can slow the consumption of IP address space
 - ⊙ Loop detection could efficiently eliminate the influence caused by port loopback by detecting the existence of loopback
 - ⊙ IPDT can track IP device status and realize interaction with other applications
 - ⊙ Bandwidth management and flow control can reasonably distribute network bandwidth, preventing unpredictable network status
 - ⊙ Port isolation could achieve port isolation in the same VLAN and save Vlan resources
 - ⊙ Smart Link link backup, providing reliable and efficient backup and fast switching mechanism
 - ⊙ Network diagnosis and troubleshooting could be conducted via Ping, Traceroute, cable diagnosis, SFP DDM
 - ⊙ Port mirroring can conduct data analysis and monitoring, which is convenient for online debugging

Dimension

Unit: mm

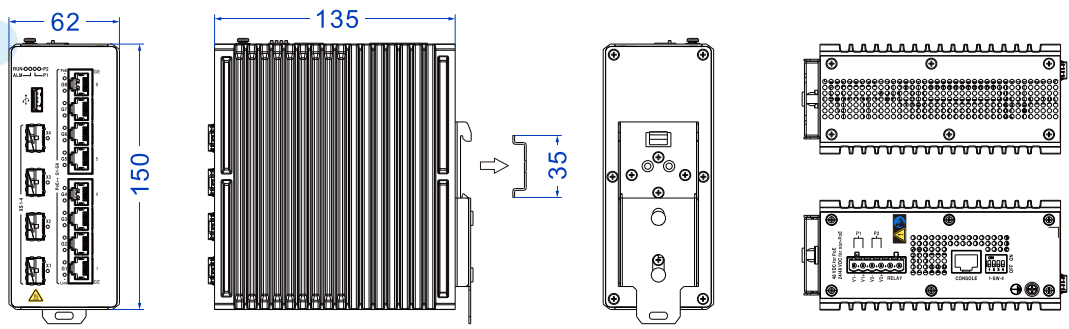

Specification

<p>Standard & Protocol</p>	<p>IEEE 802.3 for 10Base-T IEEE 802.3u for 100Base-TX IEEE 802.3ab for 1000Base-T IEEE 802.3z for 1000Base-X IEEE 802.3ae for 10GbE SFP+ IEEE 802.3x for Flow Control IEEE 802.1D for Spanning Tree Protocol IEEE 802.1w for Rapid Spanning Tree Protocol IEEE 802.1s for Multiple Spanning Tree Protocol ITU-T G.8032 for ERPS IEEE 802.1Q for VLAN IEEE 802.1AB for LLDP IEEE 802.3ad for LACP</p>
<p>Management</p>	<p>SNMP v1/v2 c/v3 centralized management of devices, RMON, port mirroring, LLDP, DHCP, Relay, port speed limit, port isolation, port statistics, file management, online upgrades, log information, Syslog, PoE management</p>
<p>Security</p>	<p>User privilege classification, ACL, SSH/HTTPS protocol authorization, access control, SNMP, RMON, link flap protection, port loop detection, IPDT, IPv6DT, Smart-Link, NAT, port alarm, temperature alarm, power alarm, network load alarm</p>
<p>Switch Function</p>	<p>802.1Q VLAN, MAC, static aggregation, LACP, ARP, storm suppression</p>
<p>Unicast / Multicast</p>	<p>IGMP-Snooping, MLD-Snooping, IGMP, MLD, PIM-SM, PIM-DM, IPv6-PIM-SM, IPv6-PIM-DM</p>
<p>Redundancy Technology</p>	<p>Ring, MRP, STP/RSTP/MSTP, ERPS</p>

Routing Technique	RIP, RIPng, OSPF, OSPFv3, ISIS, VRRP, IPv6 VRRP, BGP
Troubleshooting	Ping, Traceroute, Network Cable Diagnosis, DDM
Time Management	NTP
PoE	Maximum power: 90W PoE power supply pins: 1 and 2 are positive, 3 and 6 are negative, 4 and 5 are positive, 7 and 8 are negative
Interface	Gigabit copper port: 10/100/1000Base-T(X) adaptive or forced mode, RJ45, automatic flow control, full/half duplex mode adaptive, MDI/MDI-X automatic detection; A single port supports a maximum of 90W PoE power supply output. PoE power supply pin 1 and 2 are positive, 3 and 6 are negative, 4 and 5 are positive, and 7 and 8 are negative 10Gigabit SFP+ slot: 1G/2.5G/10G Base-X self-adaption or forced mode, SFP+ slot Console port: CLI command line management port (RS-232), RJ45 Alarm port: 6-pin 5.08mm pitch terminal blocks, alarm occupies 2-pin, supports 1 relay alarm output, current load capacity is 5A@30VDC or 10A@125VAC or 5A@250VDC USB port: Type-A USB 2.0 Female (reserved)
Indicator	Power indicator, running indicator, alarm indicator, interface indicator, PoE indicator
Switch Property	Transmission mode: store and forward MAC address: 16K Cache: 12Mbit Backplane bandwidth: 128Gbps Switch delay: <10 μ s
Power Supply	Power input: 2 48VDC (44~57VDC), dual power supply redundancy, support anti-reverse connection Connection method: adopt 6-pin 5.08mm pitch terminal blocks (includes 4-pin power supply)
Power Consumption	No-load at normal temperature: 6.72W@48VDC Full-load at normal temperature: 352.3W@48VDC (with PoE) No-load at high temperature: 9.22W@48VDC Full-load at high temperature: 357.6W@48VDC (with PoE)

Working Environment

Operating temperature: -40~75°C
Storage temperature: -40~85°C
Relative humidity: 5%~95% (no condensation)

Mechanical Structure

Housing: IP30 protection, metal
Installation: DIN-Rail mounting
Dimension (W x H x D): 62mm×150mm×135mm
Weight: 1.471kg

Industrial Standard

IEC 61000-4-2 (ESD, electronic static discharge), Level 4

- Air discharge: ± 15kV
- Contact discharge: ±8kV

IEC 61000-4-4 (EFT, electrical fast transient pulses), Level 4

- Power supply: ±4kV
- Ethernet interface: ±2kV
- Relay: ±4kV

IEC 61000-4-5 (Surge), Level 4

- Power supply: common mode ±6kV, differential mode ±2kV
- Ethernet port: common mode ±6kV, differential mode ±2kV
- Relay: common mode ±6kV, differential mode ±2kV

Shock: IEC 60068-2-27

Free fall: IEC 60068-2-31

Vibration: IEC 60068-2-6

Authentication

CE, FCC, RoHS

Warranty

5 years

Ordering Information

Model	Gigabit Copper Port	10Gigabit SFP+ Slot	USB	PoE Power	Power Supply
ICS6400BT-8GP4XS-2LV-N	8	4	1	360W	2 48VDC (44~57VDC) dual power supply redundancy