

SICOM3000S Industrial Ethernet Switch

Hardware Installation Manual

Publication Date: Apr. 2023

Version: V1.0

No.:

KYLAND

SICOM3000S Industrial Ethernet Switch

Hardware Installation Manual

Disclaimer: Kyland Technology Co., Ltd. tries to keep the content of this manual as accurate and as updated as possible. This document is not guaranteed to be error-free, and we reserve the right to amend it without notice to users.

All rights reserved.

No part of this documentation may be excerpted, reproduced, translated, annotated or duplicated, in any form or by any means without the prior written permission of KYLAND Corporation.

Copyright © 2023 Kyland Technology Co., Ltd.

Notice for Safety Operation

The product performs reliably as long as it is used according to the guidance. Artificial damage or destruction of the device should be avoided. Before using the device, read this notice carefully for personal and equipment safety. Please keep the manual for further reference. Kyland is not liable to any personal or equipment damage caused by violation of this notice.

- Do not place the device near water sources or damp areas. Keep the ambient relative humidity within the range from 5% to 95% (non-condensing).
- Do not place the device in an environment with high magnetic field, strong shock, or high temperature. Keep the working and storage temperatures within the allowed range.
- Install and place the device securely and firmly.
- Please keep the device clean; if necessary, wipe it with a soft cotton cloth.
- Do not place any irrelevant materials on the device or cables. Ensure adequate heat dissipation and tidy cable layout without knots.
- Wear antistatic gloves or take other protective measures when operating the device.
- Avoid any exposed metal wires because they may be oxidized or electrified.
- Install the device in accordance with related national and local regulations.
- Before power-on, make sure the power supply is within the allowed range of the device. High voltage may damage the device.
- Power connectors and other connectors should be firmly interconnected.
- Do not plug in or out the power supply with wet hands. When the device is powered on, do not touch the device or any parts with wet hands.
- Before operating a device connected to a power cable, remove all jewelry (such as rings, bracelets, watches, and necklaces) or any other metal objects, because they may cause electric shock or burns.
- Do not operate the device or connect or disconnect cables during an electrical storm.
- Use compatible connectors and cables. If you are not sure, contact our sales or technical support personnel for confirmation.

- Do not disassemble the device by yourself. When an anomaly occurs, contact our sales or technical support personnel.
- If any part is lost, contact our sales or technical support personnel to purchase the substitute. Do not purchase parts from other channels.
- Dispose of the device in accordance with relevant national provisions, preventing environmental pollution.

In the following cases, please immediately shut down the power supply and contact Kyland:

- Water gets into the device.
- Device damage or shell damage.
- Device operation or performance has abnormally changed.
- The device emits odor, smoke or abnormal noise.

NOTE: This equipment has been tested and found to comply with the limits for a Class A digital device, pursuant to part 15 of the FCC Rules. These limits are designed to provide reasonable protection against harmful interference when the equipment is operated in a commercial environment. This equipment generates, uses, and can radiate radio frequency energy and, if not installed and used in accordance with the instruction manual, may cause harmful interference to radio communications. Operation of this equipment in a residential area is likely to cause harmful interference in which case the user will be required to correct the interference at his own expense.

NOTE: This product must not be used in residential areas.

This product may cause interference if used in residential areas. Such use must be avoided unless the user takes special measures to reduce electromagnetic emissions to prevent interference to the reception of radio and television broadcasts.

Contents

1	Product Overview	5
2	Structure and Interface	6
2.1	Front Panel	6
2.2	Top Panel.....	7
3	Mounting.....	8
3.1	Dimension	8
3.2	Mounting Modes and Steps	8
3.3	DIN Mounting.....	9
4	Connection	11
4.1	10/100/1000Base-T(X) ethernet port.....	11
4.2	POE Function.....	12
4.3	1000Base-X, 10/100/1000Base-T(X)SFP interface.....	13
4.3.1	SFP optical module	14
4.4	Console Port	15
4.4.1	RJ45 Console Port	15
4.5	Grounding	16
4.6	Power Terminal Block	16
4.7	Alarm Terminal Block	18
5	Reset.....	20
6	LED Status	21
7	Access.....	23
7.1	Access through Console Port.....	23
7.2	Access through Telnet	25
7.3	Access through Web	26
8	Basic Features and Specifications.....	27

1 Product Overview

SICOM3000S series switch is a two-layer network management PoE industrial Ethernet switch developed by Kyland for petroleum and petrochemical, factory automation, intelligent transportation, rail transit and other industries.

This series of switches supports DIN rail mounting, provides RJ45 management port, supports Console、Telnet、Web management; Reset button has one-click recovery function.

This switch can be configured with up to 4 1000Base-X, 10/100/1000Base-T(X) SFP ethernet interfaces and 8 100/1000Base-T(X) POE ethernet interfaces. 100/1000Base-T(X) ethernet interface supports IEEE802.3at (Compatible IEEE802.3af), The switch can provide a maximum of 240W (L16) power. The specific configuration is as follows.

Table 1 SICOM3000S Configuration Table

Model number	SICOM3000S-4GX8GP-L16-L16
Code definition	Code Selection
Ports	4GX8GP
	Description: 4GX8GP: 4 1000Base-X, 10/100/1000Base-T(X) SFP interface; 8 10/100/1000 Base-T(X) POE electrical interface;
PS1-PS2: power input	L16-16: 45V-57VDC (dual redundancy), support 802.3af; L16-16: 51V-57 VDC (dual redundancy), support 802.3at.

2 Structure and Interface



Caution:

It is recommended to purchase the port dustproof shield (optional) to keep ports clean and ensure switch performance.

2.1 Front Panel

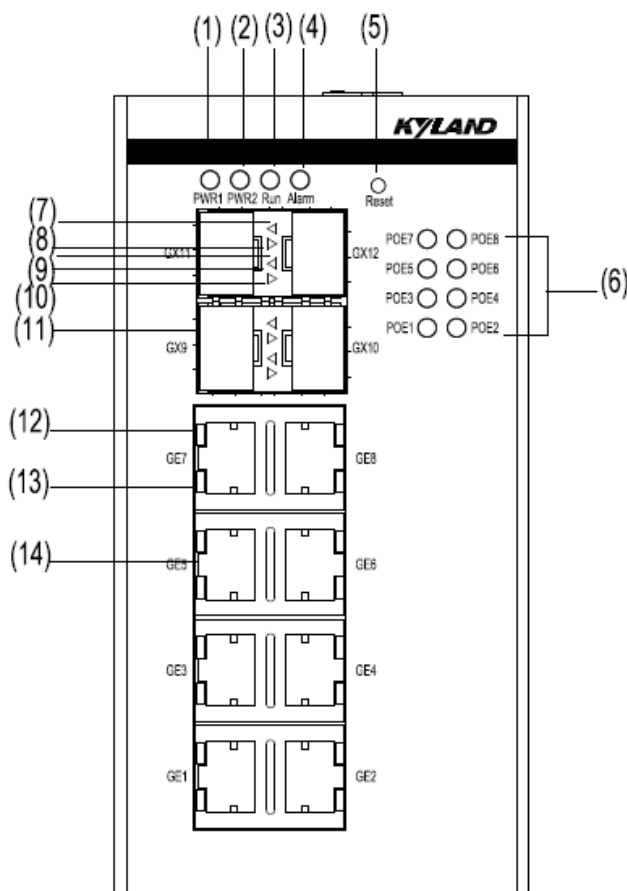

Figure 1 Front panel

- | | | |
|---|--|--------------------|
| (1) PWR 1 LED | (2) PWR 2 LED | (3) Run LED |
| (4) Alarm LED | (5) Reset button | (6) POE output LED |
| (7) 1000M SFP interface link status LED (green) | (8) 1000M SFP interface speed LED (yellow) | |
| (9) 1000M SFP interface link status LED (green) | (10) 1000M SFP interface speed LED (yellow) | |
| (11) 1000M SFP interface | (12) 10/100/1000Base-T(X) ethernet interface | |
| (13) 10/100/1000Base-T(X) ethernet interface speed LED (yellow) | | |

(14) 10/100/1000Base-T(X) ethernet link status LED (green)

2.2 Top Panel

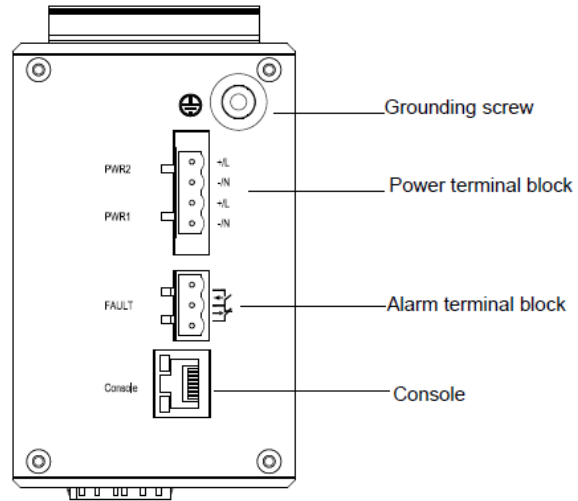

Figure 2 Top panel

3 Mounting

3.1 Dimension

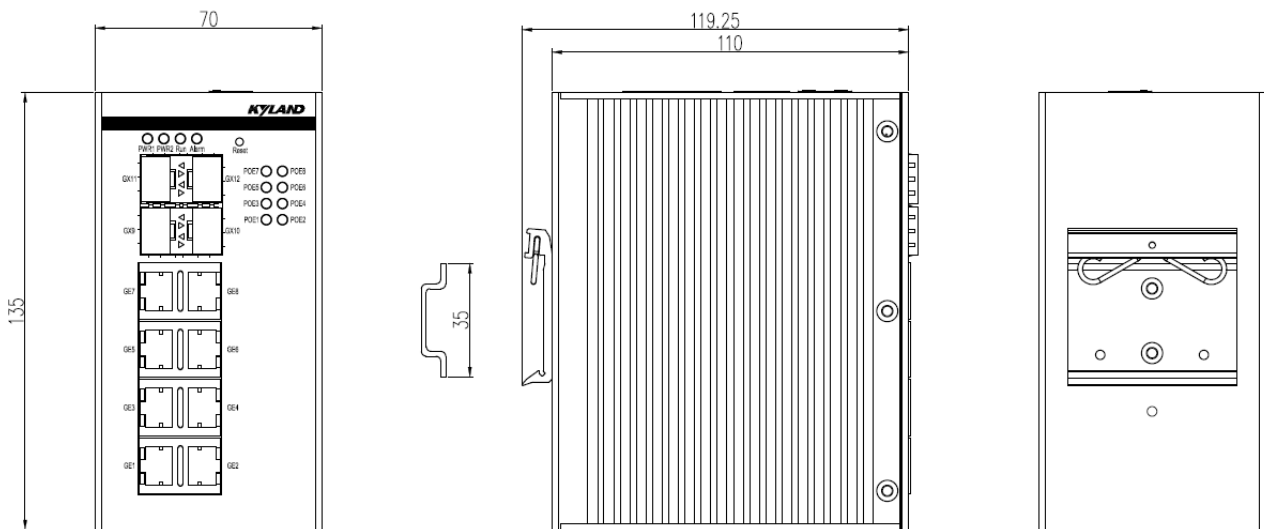

Figure 3 DIN-rail mounting dimension (mm)



Caution:

- As part of the heat dissipation system, the switch housing becomes hot during operation. Please do not cover the switch housing when the switch is running.
- The figures in this manual are only for reference.

3.2 Mounting Modes and Steps

The switch supports DIN-rail mounting. Before installation, make sure that the following requirements are met.

- 1) Environment: temperature (-40°C to 75°C), ambient relative humidity (5% to 95%, non-condensing).
- 2) Power requirements: Verify that the operating voltage matches the voltage range identified on the switch.
- 3) Grounding resistance: <math><5\Omega</math>.
- 4) Avoid direct sunlight, away from heating sources or areas with strong electromagnetic interference.

5) The installation environment should meet the requirements of the authority, do not touch the equipment directly by hand, avoid causing personal injury.

6) Only professionals or trained and qualified personnel can perform installation, replacement and maintenance operations for this switch.

3.3 DIN Mounting

- DIN-rail mounting

Step 1: Select the mounting position for the switch and ensure enough space and smooth heat dissipation.

Step 2: Clamp the top of the rail seat on the DIN rail, slightly force up the bottom of the device, rotate the device follow arrow 2 as below figure, ensure the DIN rail reliably fits in the connecting seat.

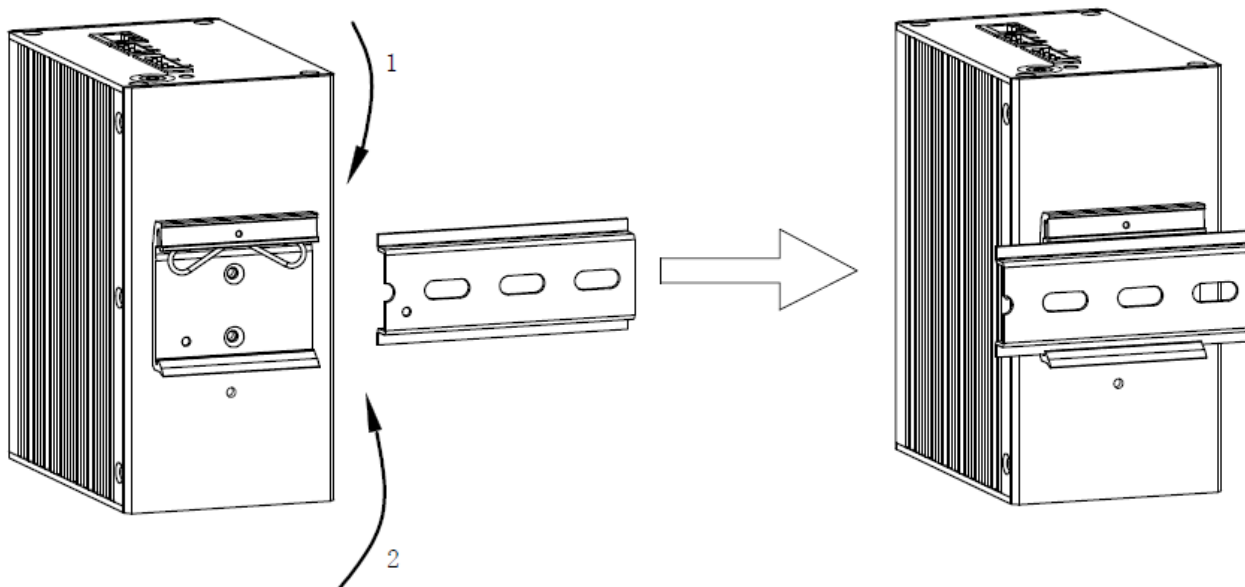

Figure 4 DIN-rail mounting

- DIN-rail dismounting

Step 1: As shown in the following figure, press the device downward and move the device in direction 1 until the bottom of the device is detached from the DIN rail.

Step 2: Pull the device upward and move the device in direction 2 until the device is removed from the DIN rail completely.

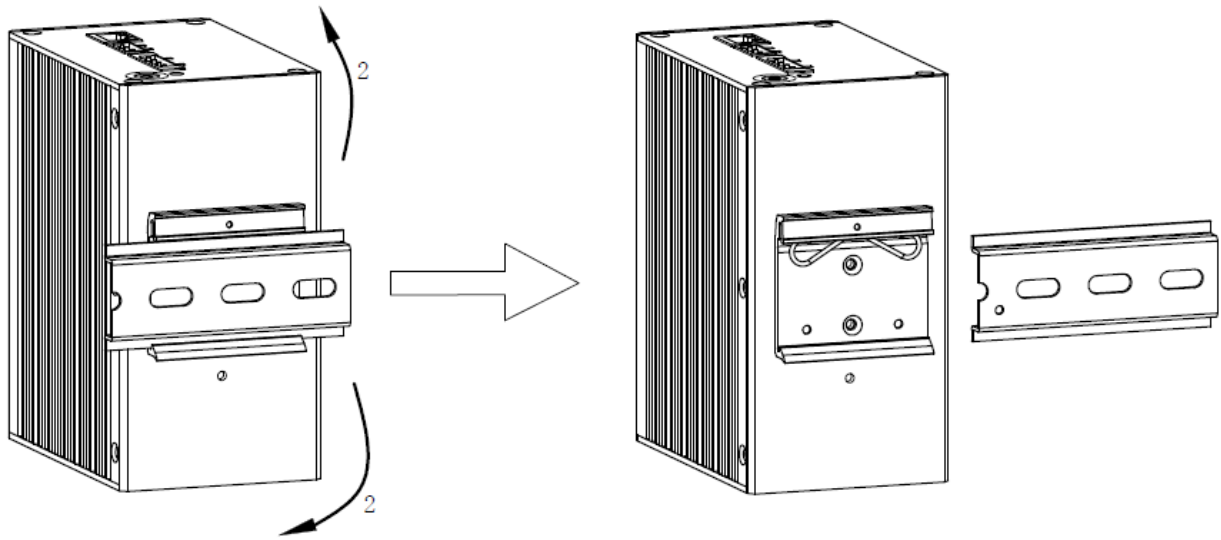

Figure 5 DIN-rail dismounting

4 Connection

4.1 10/100/1000Base-T(X) ethernet port

10/100/1000Base-T(X) Ethernet port uses standard RJ45 connector. The port supports self-adaptive and it can be automatically configured to 10M/100M/1000M, full or half duplex mode. The port can also support auto MDI/MDI-X, that is connect the port to a terminal or network device with a straight-through or cross-over cable.

- Pin Definition

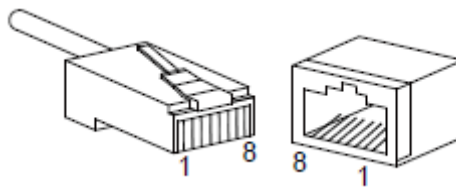



Figure 6 RJ45 PIN number

Table 2 10/100/1000Base-T(X) Ethernet Port PIN Definition

PIN	MDI-X signal name	MDI signal name
1	Receive Data+ (RD0+)	Transmit Data+ (TD0+)
2	Receive Data- (RD0-)	Transmit Data- (TD0-)
3	Transmit Data+ (TD1+)	Receive Data+ (RD1+)
4	Receive Data+ (RD2+)	Transmit Data+ (TD2+)
5	Receive Data- (RD2-)	Transmit Data- (TD2-)
6	Transmit Data- (TD1-)	Receive Data- (RD1-)
7	Transmit Data+ (TD3+)	Receive Data+ (RD3+)
8	Transmit Data- (TD3-)	Receive Data- (RD3-)

 **Note:** "+" and "-" indicate level polarities.

- Wiring Sequence

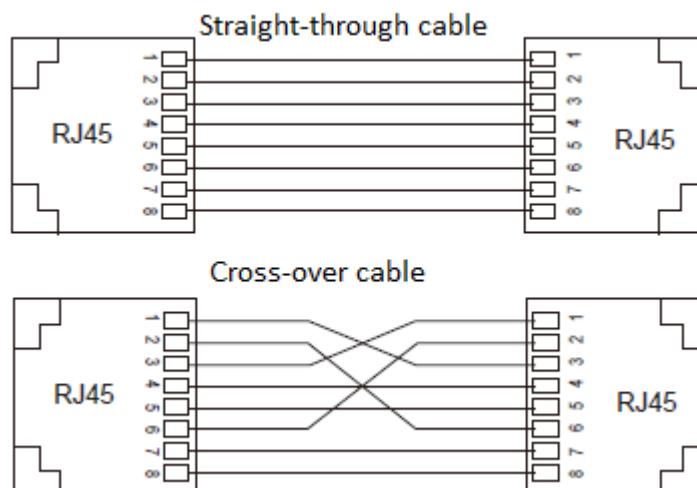

Figure 7 10/100/1000Base-T(X) RJ45 Connection Using Straight-through/Cross-over Cable



Note:

The color of the cable for RJ45 connector follow standard 568B (1-orange and white, 2-orange, 3-green and white, 4-blue, 5-blue and white, 6-green, 7-brown and white, and 8-brown.)

4.2 POE Function

This device power the external PD (Power Device) through 10/100/1000 Base-T (X) or 10/100/1000Base-T(X) ethernet interface as PSE (Power Sourcing Equipment). 10/100/1000Base-T(X) and 10/100/1000Base-T(X) ethernet port support IEEE802.3at (compatible IEEE802.3af), each POE port supplies up 30W power, L16-L16 supply up 240W power.

1、 POE definition

POE (Power over Ethernet) means that a device uses twisted-pair wires to power an external PD (power device) through an ethernet interface. A maximum power supply distance is 100 m.

2、 POE power supply mode

This device supports to power supply to PD over data signal wire.

Table 3 RJ45 PIN definition

PIN	MDI-X signal name	MDI signal name	POE power supply
-----	-------------------	-----------------	------------------

RJ45 interface			
1	Transmit/Receive Data (TRD1+)	Transmit/Receive Data (TRD0+)	V-
2	Transmit/Receive Data (TRD1-)	Transmit/Receive Data (TRD0-)	V-
3	Transmit/Receive Data (TRD0+)	Transmit/Receive Data (TRD1+)	V+
4	Transmit/Receive Data (TRD3+)	Transmit/Receive Data (TRD2+)	--
5	Transmit/Receive Data (TRD3-)	Transmit/Receive Data (TRD2-)	--
6	Transmit/Receive Data (TRD0-)	Transmit/Receive Data (TRD1-)	V+
7	Transmit/Receive Data (TRD2+)	Transmit/Receive Data (TRD3+)	--
8	Transmit/Receive Data (TRD2-)	Transmit/Receive Data (TRD3-)	--

 **Note:**
 "+" and "-" indicate level polarities.

4.3 1000Base-X, 10/100/1000Base-T(X)SFP interface

1000Base-X,10/100/1000Base-T(X)SFP interface (gigabit SFP interface) requires an SFP optical/electrical module to enable data transmission. The following table lists the gigabit SFP optical/electrical modules (optional) supported by the series switches.

Table 4 SFP optical/electrical modules

Model number	Interface	MM/SM	Connector	Wavelength	Distance
IGSFP-M-SX-LC-850-0.55	1000Base-X	MM	LC	850nm	0.55km
IGSFP-S-LX-LC-1310-10	1000Base-X	SM	LC	1310nm	10km
IGSFP-S-LH-LC-1310-40	1000Base-X	SM	LC	1310nm	40km
IGSFP-S-ZX-LC-1550-80	1000Base-X	SM	LC	1550nm	80km

 **Note:**
 The switch support optical power detection of SFP port, this function needs SFP module with DDM, if you want to get more detailed information, please contact market or technical engineer.

4.3.1 SFP optical module

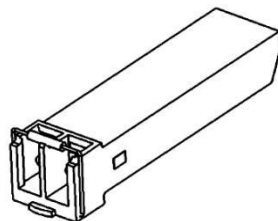

Figure 8 SFP optical module

SFP optical module interface adopts standard LC fiber connector, each interface is divided into transmit port (TX port) and receive port (RX port). To enable communication between Device A and Device B, connect the TX port of Device A to the RX port of Device B, and the RX port of Device A to the TX port of Device B, as shown in the below figure.



Figure 9 SFP optical module connection

- How to Connect the SFP Optical Module

Insert the SFP optical module into the SFP slot in the switch, and then insert the fibers into the TX port and RX port of the SFP module.

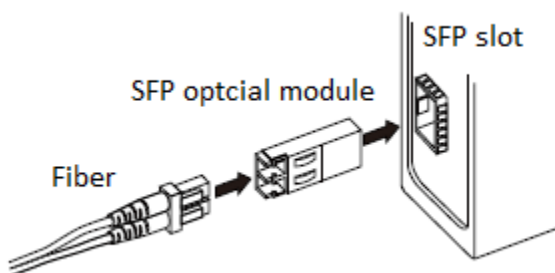

Figure 10 Connecting the SFP Optical Module

Confirm the RX port and TX port of an SFP optical module:

1. Insert the two connectors at one end of fibers into the two interfaces of SFP module, and then insert the two connectors at the other end of fibers into the two interfaces at the corresponding end.

2. View the corresponding connection status LED: If the LED is on, the connection is correct. If the LED is off, the link is not connected. This may be caused by incorrect connection of the TX and RX ports. In this case, swap the two connectors at one end of the fibers.



Caution:

- The device uses laser to transmit signals over fiber. The laser meets the requirements of level 1 laser products. Do not look directly at the fiber port to avoid to harm to your eyes when device is powered on.
- For SFP module which transmission distance is longer than 60km, do not use a short fiber (<20km) to connect to avoid the SFP module is brunt since the optical power is saturation.

4.4 Console Port

4.4.1 RJ45 Console Port

Connect the 9-pin serial port of a PC to the console port of the switch with a DB9-RJ45 console cable. Then you can configure, maintain, and manage the switch by running Hyper Terminal in Windows OS.

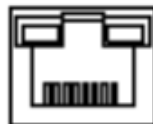

Console

Figure 11 Console port

- DB9-RJ45 Console Cable

One end of a DB9-RJ45 console cable is crimped RJ45 connector to be inserted into the console port of the switch, and the other end is the DB9 connector to be inserted into the 9-pin serial port of a PC.

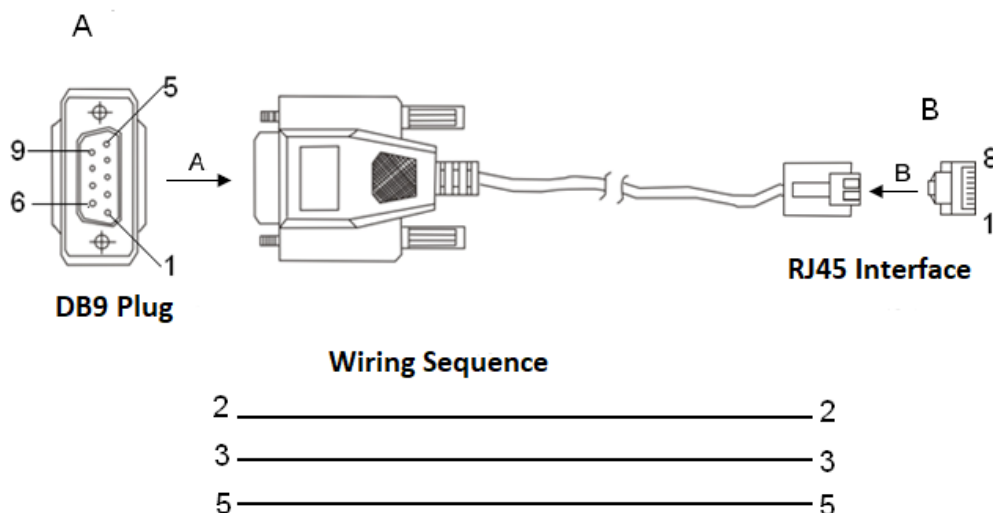

Figure 12 Wiring Sequence of DB9-RJ45 Console Cable

Table 5 Pin Definitions of DB9 Port (9-Pin Serial Port) and RJ45 Port (Console Port)

DB9 Port (9-Pin Serial Port)		RJ45 Port (Console Port)	
Pin	Signal	Pin	Signal
2	RXD (Receive Data)	2	TXD (Transmit Data)
3	TXD (Transmit Data)	3	RXD (Receive Data)
5	GND (Grounding)	5	GND (Grounding)

4.5 Grounding

Normal grounding of device is important for lightning protection and anti-interference, so the user must connect the ground wire correctly. and ground before power on, and then disconnect the ground wire after power off.

The switch provides a grounding screw on the top panel for chassis grounding. After crimping one end of the grounding cable to a cold pressed terminal, fix the grounding screw and connect the other end to the earth firmly.



Note:

Cross-sectional area of the chassis grounding cable > 2.5 mm²; grounding resistance < 5Ω.

4.6 Power Terminal Block

The power terminal is located on the cover plate of the device, and the power cord is

connected to the terminal block to supply power to the device. This device supports redundant power input and adopts 4 core 5.08 mm spacing plug-in terminal block. when any one of the power supply failure, the device can run normally without interruption, improve the reliability of network operation.



Note:

- Power cord cross-sectional area should be above 0.75mm² (max cross-sectional is 2.5mm²); grounding resistance < 5Ω.
- Copper conductor must be used for field wiring and the temperature should meet 85°C.

● 4-Pin 5.08mm-Spacing Plug-in Terminal Block

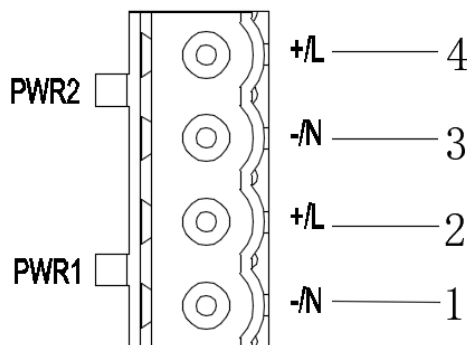

Figure 13 4-Pin 5.08mm-Spacing Plug-in Terminal Block (socket)

Table 6 Pin Definitions of 4-Pin 5.08mm-Spacing Plug-in Terminal Block

No.	Signal	DC Definition	AC Definition
1	-/N	PWR1: -	PWR1: N
2	+/L	PWR1: +	PWR1: L
3	-/N	PWR2: -	PWR2: N
4	+/L	PWR2: +	PWR2: L

● Wiring and Mounting

Step 1: Ground the device properly according to section 4.5.

Step 2: Remove the power terminal block from the device.

Step 3: Insert the power wires into the power terminal block according to Table 6 and fix the wires.

Step 4: Insert the terminal block with the connected wires into the terminal block socket on the device.

Step 5: Connect the other end of the power wires to the external power supply system according to the power supply requirements of the device. View the status of the power LEDs on the front panel. If the LEDs are on, the power is connected correctly.

Wiring and mounting should meet the following specifications.

Table 7 Wiring and Mounting Specifications

Terminal Block type	Torque requirements	Cross-sectional area (AWG)
Plug-in Terminal Block	4.5-5.0 lb-in	12-24



Caution:

- Before connecting the device to power supply, make sure that the power input meets the power requirement.
- To meet the UL requirements, the power supply of the device should conform the Class 2.



Warning:

- Do not touch any exposed conducting wire, terminal or component with a voltage warning sign, it may cause damage to humans.
- Do not remove any part or plug in or out any connector when the device is powered on.

4.7 Alarm Terminal Block

The alarm terminal block is located on the cover plate of the device for alarm output. When the device works normally, the alarm relay normally-open contact is on, and normally-close contact is off; When an alarm occurs, normally-open contact is off and normally-close contact is on. The normally-open and normally-close contact of delay is output through the 3-pin 5.08-spacing plug-in terminal blocks.

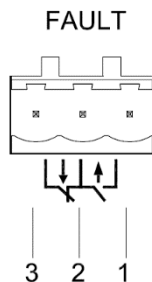

Figure 14 3-Pin 5.08mm-Spacing Plug-in Terminal Block (Socket)

Electrical parameters of relay:

Maximum voltage: 250VAC/220VDC

Maximum current: 2A

Maximum power: 60W

Maximum insulation withstand voltage: 2KV



Note:

- Pin 1 and Pin 2 is a normally-open contact, Pin 2 and Pin 3 is a normally-close contact. When the device works normally, it is close between Pin 1 and Pin 2, it is open between Pin 2 and Pin 3; when an alarm occurs, it is open between Pin 1 and Pin 2, it is close between Pin 2 and Pin 3.
- Copper conductor must be used for field wiring and the temperature should meet 75°C.

● **Wiring and Mounting**

Step 1: Remove the alarm terminal block from the switch.

Step 2: Fix the three wires for alarm into the alarm terminal block according to the above note.

Step 3: Insert the alarm terminal block into its socket.

Wiring and mounting should meet the following specifications

Table 8 Wiring and Mounting Specifications

Terminal Block type	Torque requirements	Cross-sectional area (AWG)
Plug-in Terminal Block	4.5-5.0 lb-in	12-24

5 Reset

The reset button is located in the front panel of the device and has the function of restarting and restoring the default configuration. Continue to press the reset button 0.5~3 seconds then release to complete the device restart. Press the reset button continuously for more than 3 seconds then release to restore the default configuration and restart.

**Caution:**

If you want to restart the device, be careful not to press the reset button for more than 3 seconds to prevent the device restore the default configuration.

6 LED Status

Table 9 LEDs description

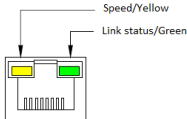
LED	status	Description
Power 1 LED	ON	Power 1 is connected and run normally.
	OFF	Power 1 is not connected or running abnormally.
Power 2 LED	ON	Power 2 is connected and run normally.
	OFF	Power 2 is not connected or running abnormally.
Run LED	Blinking	The CPU run normally
	ON	The device is starting up
	OFF	The CPU does not start up
Alarm LED	ON	Alarm
	OFF	No alarm
1000M SFP speed status LED (Yellow)	ON	1000M working status (1000Base-X)
	OFF	10/100M working mode or no connection
1000Base-FX or 1000M SFP link status LED (Green)	ON	The valid network connection is established
	Blinking	Network activity
	OFF	The valid network connection is not established
		
10/100/1000Base-T(X) Ethernet port speed LED (Yellow)	ON	1000M working mode (1000Base-T)
	OFF	10/100M working mode or no connection
10/100/1000Base-T(X) Ethernet port link status LED (Green)	ON	The valid network connection is established
	Blinking	Network activity
	OFF	The valid network connection is not established
Ethernet port POE LED-POE	ON	POE port supply power normally
	Blinking	POE port supply power abnormally

	OFF	POE port no power
--	-----	-------------------

7 Access

You can access the switch in following three ways:

7.1 Access through Console Port

Step 1: Connect the console port of the switch to the 9-pin serial port of a PC with the delivered DB9-RJ45 console cable.

Step 2: Open Hyper Terminal in Windows OS. On the Windows desktop, click Start → All Programs → Accessories → Communications → Hyper Terminal.

Step 3: Create a new connection "Switch", as shown in the below figure.



Figure 15 Create new connection

Step 4: Select the correct communication port to connect, as shown in the below figure.



Figure 16 Select correct communication port



Note:

Right-click [My Computer] and select [Property]. Click [Hardware] → [Device Manager] → [Port] to view the communication port.

Step 5: Set port parameters (Bits per second: 115200, Data bits:8, Parity: None, Stop bits:1, and Flow control: None), as shown in the below figure.



Figure 17 Port configuration

Step 6: Click OK to enter the CLI interface. Then the below commands can be used to perform operations.

Table 10 CLI Command

View type	Command	Description
Management view	SWITCH#show interface vlan 1	Query the current IP address of the switch
Management view	SWITCH#show version	Query the version of the switch
Management view	SWITCH#reboot	Restart the switch
Management view	SWITCH#load default	Restore the factory default configuration
Management view	SWITCH#config terminal	Enter Global Configuration Mode

7.2 Access through Telnet

Step 1: Connect the network port of the PC to the Ethernet port of the switch with a network cable.

Step 2: On the Windows desktop, click Start and Run. Enter "telnet IP address" in the run dialog box. For example, if the IP address of the device is 192.168.0.2 (default IP address of the Kyland switch), enter "telnet 192.168.0.2" in the dialog box.

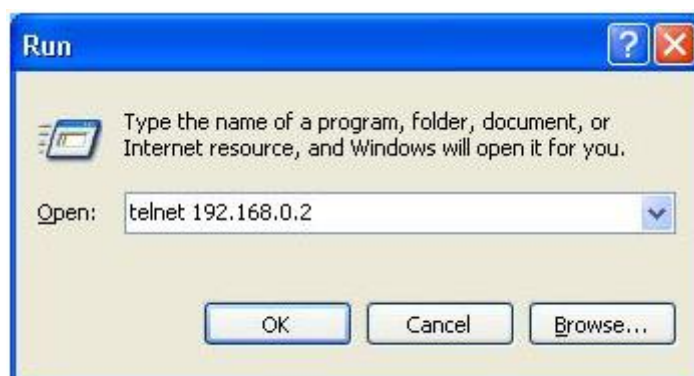

Figure 18 Access through Telnet

Step 3: Click OK and you can run the commands in Table 10 to perform operations in the Telnet CLI.

7.3 Access through Web

Step 1: Connect the network port of the PC to the RJ45 port of the switch with an RJ45-RJ45 cable.

Step 2: Enter the IP address of the switch in the address box of the browser. You can log in to the Web management interface by using default user name "admin" and password "123".

**Note:**

- IE8.0 or above version is recommended.
 - For details about how to access the switch and other operations, please refer to the Web operation manual.
-

8 Basic Features and Specifications

Power supply

Power identifier	Rated Input Voltage Range	Maximum Input Voltage Range
L16-L16	48VDC	18-57VDC
Terminal Block	4-pin 5.08mm spacing plug-in terminal block	

Rated Power Consumption

Rated power consumption	4GX8GP-no POE:10W 4GX8GP-POE:240W
-------------------------	--------------------------------------

Physical

Housing	Metal, no fan
IP level	IP40
Mounting	DIN-rail mounting
Dimensions (W×H×D)	70mm×135mm×110mm (excluding connector, DIN rail)
Weight	1.0KG

Environment

Operation temperature	-40℃～+75℃
Storage temperature	-40℃～+85℃
Ambient relative humidity	5%～95% non-condensing

Warranty

Warranty	5 years
----------	---------

KYLAND

Service hotline: 010-88796676

FAX: 010-88796678

Website: <http://www.kyland.com.cn>

Email: services@kyland.com.cn

For more information about Kyland products,
please visit our website:

<http://www.kyland.com.cn>

<http://www.kyland.com>