

# **Opal10/Opal20 Series Entry-Level Industrial Ethernet Switch Hardware Installation Manual**

Publication Date: Nov. 2018

Version: V1.2

No.: 112023039

***KYLAND***

## **Certificate of Compliance**

EU Directive 2011/65/EU (RoHS-Directive)

Dear Ladies and Gentlemen,

According to the EU Directive 2011/65/EU the use of several substances for electrical and electronic equipment in defined categories is restricted. Kyland hereby declares that the parts used in our products are produced in full compliance with the Directive 2011/65/EU “Restriction of the Use of Certain Hazardous Substances in Electrical and Electronic Equipment” (RoHS), including all amendments to the EU-directive (e.g. The Restrictions of DecaBDE).

This information and our technical advice – whether verbal, in writing or by way of trials – are given in good faith and to the best of our knowledge but without liability and warranty, unless law admits the liability or warranty. This also applies where proprietary rights of third parties are involved. Our advice does not release you from the obligation to check its validity and to test our products as to their suitability for the intended processes and applications. The application, use and processing of our products and the products manufactured by you on the basis of our technical advice are beyond our control and, therefore, entirely your own responsibility. Our products are sold in accordance with the current version of our General Conditions of Sale and Delivery.

**Disclaimer:** Kyland Technology Co., Ltd. tries to keep the content of this manual as accurate and as updated as possible. This document is not guaranteed to be error-free, and we reserve the right to amend it without notice to users.

**All rights reserved.**

No part of this documentation may be excerpted, reproduced, translated, annotated or duplicated, in any form or by any means without the prior written permission of KYLAND Corporation.

**Copyright © 2018 Kyland Technology Co., Ltd.**



## Notice for Safety Operation

The product performs reliably as long as it is used according to the guidance. Artificial damage or destruction of the device should be avoided. Before using the device, read this notice carefully for personal and equipment safety. Please keep the manual for further reference. If the device used not according to the specified way by Kyland, the protection provided by the device maybe diminished. And Kyland is not liable to any personal or equipment damage caused by violation of this notice.

- Ensure the area where the device is used is clean and dry. Keep the ambient relative humidity within the range from 5% to 95% (non-condensing).Be suitable for indoor use.
- Do not place the device in an environment with high magnetic field, strong shock, or high temperature. Keep the working and storage temperatures within the allowed range.
- Install and place the device securely and firmly.
- Please keep the device clean; if necessary, wipe it with a dry soft cotton cloth.
- Do not place any irrelevant materials on the device or cables. Ensure adequate heat dissipation and tidy cable layout without being entangled or knotted.
- Wear antistatic gloves or take other protective measures when operating the device.
- Avoid any exposed metal wires because they may be oxidized or electrified.
- Install the device in accordance with related national and local regulations.
- Before power-on, make sure the power supply is within the allowed range of the device. High voltage may damage the device.
- Power connectors and other connectors should be firmly interconnected.
- Do not plug in or out the power supply with wet hands. When the device is powered on, do not touch the device or any parts with wet hands.
- Before operating a device connected to a power cable, remove all jewelry (such as rings, bracelets, watches, and necklaces) or any other metal objects, because they may cause electric shock, burns, or welding.
- Do not operate the device or connect or disconnect cables during an electrical storm.
- Use compatible connectors and cables. If you are not sure, contact our sales or technical support personnel for confirmation.
- Do not disassemble the device by yourself. When an anomaly occurs, contact our sales or technical support personnel.
- If any part is lost, contact our sales or technical support personnel to purchase a replacement. Do not purchase parts from other channels.
- Dispose of the device in accordance with relevant national provisions, preventing

environmental pollution.

Note : The security of any system merged with this device is the responsibility of the assembler.

In the following cases, please immediately shut down your power supply and contact your Kyland representative:

- Water gets into the equipment.
- Equipment damage or shell damage.
- Equipment operation or performance has abnormally changed.
- The equipment emits odor, smoke or abnormal noise.

The following information applies when operating this device in hazardous locations:

Suitable for use in Class I, Division 2, Groups A, B, C and D Hazardous Locations, or nonhazardous locations only.

Cet appareillage est utilisable dans les emplacements de Classe I, Division 2, Groupes A, B, C et D, ou dans les emplacements non dangereux seulement.

**WARNING: EXPLOSION HAZARD**

- Do not disconnect equipment while the circuit is live or unless the area is known to be free of ignitable concentrations.
- Substitution of any component may impair suitability for Class I, Division 2.

**AVERTISSEMENT: RISQUE D'EXPLOSION**

- Avant de deconnecter l'equipement, couper le courant ou s'assurer que l'emplacement est designe non dangereux.
- La substitution de composants peut rendre ce materiel inacceptable pour les emplacements de Classe I, Division 2.

NOTE: This equipment has been tested and found to comply with the limits for a Class A digital device, pursuant to part 15 of the FCC Rules. These limits are designed to provide reasonable protection against harmful interference when the equipment is operated in a commercial environment. This equipment generates, uses, and can radiate radio frequency energy and, if not installed and used in accordance with the instruction manual, may cause harmful interference to radio communications. Operation of this equipment in a residential area is likely to cause harmful interference in which case the user will be required to correct the interference at his own expense.



# Contents

1 Product Overview.....	2
2 Structure and Interface.....	4
2.1 Front Panel.....	4
2.2 Top Panel.....	5
3 Mounting.....	6
3.1 Dimension Drawing.....	6
3.2 Mounting Modes and Steps.....	7
3.2.1 DIN-Rail Mounting.....	7
3.2.2 DIN-Rail Dismounting.....	8
4 Connection.....	9
4.1 10/100Base-T(X) Ethernet Port.....	9
4.2 100Base-FX Ethernet Port.....	10
4.3 100Base-X SFP Slot.....	11
4.4 10/100/1000Base-T(X) Ethernet Port.....	11
4.5 100/1000Base-X SFP slot.....	13
4.6 Grounding.....	14
4.7 Power Terminal Block.....	15
4.8 DIP Switches.....	17
5 LEDs.....	18
6 Basic Features and Specifications.....	19
7 Certificates Used for Compliance.....	20
8 Appendix.....	21

# 1 Product Overview

Opal10/Opal20 entry-level industrial Ethernet switches are specially designed for industrial control applications.

Opal10/Opal20 supports normal-temperature-range and wide-temperature-range models. Broadcast storm protection and 100/1000Base-X SFP slots can be configured through DIP switches.

The series switches support DIN rail mounting. Opal10 provides two 100/1000Base-X SFP slots (Gigabit SFP Slot), two 10/100/1000Base-T(X) Ethernet ports, and six 10/100Base-T(X) Ethernet ports; Opal20 provides up to two 10/100/1000Base-T(X) Ethernet ports, two 100Base-FX Ethernet ports or 100Base-X SFP Slots, and sixteen 10/100Base-T(X) Ethernet ports. For details, see the following table.

Table 1 Opal10 Models

<b>Models</b>	<b>Opal10-Ports-PS1-PS2</b> <b>Opal10-E-Ports-PS1-PS2</b>
Code definition	Code option
E	E: Normal temperature range models, ambient temperature: $-10^{\circ}\text{C} \leq T_{amb} \leq +60^{\circ}\text{C}$ N/A: Wide temperature range models, ambient temperature: $-40^{\circ}\text{C} \leq T_{amb} \leq +75^{\circ}\text{C}$
Ports: S/M, T	2GX2GE6T=two 100/1000Base-X SFP slots; two 10/100/1000Base-T(X) ports; six 10/100Base-T(X) ports
Connector: parameters for SFP	SMSFP: Single mode 100Base-X SFP modules plugged into SFP slots MMSFP: Multi mode 100Base-X SFP modules plugged into SFP slots SMGSFP=Single mode 1000Base-X SFP modules plugged into SFP slots MMGSFP=Multi mode 1000Base-X SFP modules plugged into SFP slots N/A= No SFP module plugged into SFP slot while delivery
PS1-PS2: power input	LV-LV=24VAC/DC (18-30VAC, 50/60Hz; 12-48VDC), redundant power input

Table 2 Opal20 Models

<b>Model</b>	<b>Opal20-Ports-Connector-PS1-PS2</b> <b>Opal20-E-Ports-Connector-PS1-PS2</b>
Code definition	Code option
E	E: Normal temperature range models, ambient temperature: $-10^{\circ}\text{C} \leq T_{amb} \leq +60^{\circ}\text{C}$ N/A: Wide temperature range models, ambient temperature: $-40^{\circ}\text{C} \leq T_{amb} \leq +75^{\circ}\text{C}$
Ports: S/M, T	2S16T=two 100Base-FX ports, single mode; sixteen 10/100Base-T(X) ports.



	<p>2M16T=two 100Base-FX ports, multiple mode; sixteen 10/100Base-T(X) ports.                  2SFP16T=two 100Base-X SFP slots; sixteen 10/100Base-T(X) ports.                  16T= sixteen 10/100Base-T(X) ports.                  2GE2S16T= two 10/100/1000Base-T(X) RJ45 ports; two 100Base-FX, single mode fiber ports; sixteen 10/100Base-T(X) RJ45 ports                  2GE2M16T= two 10/100/1000Base-T(X) RJ45 ports; two 100Base-FX, multi mode fiber ports; sixteen 10/100Base-T(X) RJ45 ports                  2GE2SFP16T= two 10/100/1000Base-T(X) RJ45 ports; two 100Base-X, SFP slots; sixteen 10/100Base-T(X) RJ45 ports                  2GE16T= two 10/100/1000Base-T(X) RJ45 ports; sixteen 10/100Base-T(X) RJ45 ports</p>
<p>Connector: parameters for S/M</p>	<p><b>Ports with M:</b>                  SC05=SC connector, 1310nm, 5km                  ST05=ST connector, 1310nm, 5km                  FC05=FC connector, 1310nm, 5km  <b>Ports with S:</b>                  SC40=SC connector, 1310nm, 40km                  ST40=ST connector, 1310nm, 40km                  FC40=FC connector, 1310nm, 40km                  SC60=SC connector, 1310nm, 60km                  ST60=ST connector, 1310nm, 60km                  FC60=FC connector, 1310nm, 60km                  SC80=SC connector, 1550nm, 80km                  ST80=ST connector, 1310nm, 80km                  FC80=FC connector, 1310nm, 80km  <b>Ports with 100Base-X SFP:</b>                  SMSFP= Single mode 100Base-X SFP module plugged into SFP slot                  MMSFP= Multi mode 100Base-X SFP module plugged into SFP slot                  N/A= No SFP module plugged into SFP slot</p>
<p>PS1-PS2: power input</p>	<p>LV-LV=24VAC/DC (18-30VAC, 50/60Hz; 12-48VDC), redundant power input</p>



**Note:**

We reserve the right to amend the product information listed in this table without notice. To obtain the latest information, you can contact our sales or technical support personnel.



## 2 Structure and Interface



**Caution:**

It is recommended to purchase the port dustproof shield (optional) to keep ports clean and ensure switch performance.

### 2.1 Front Panel

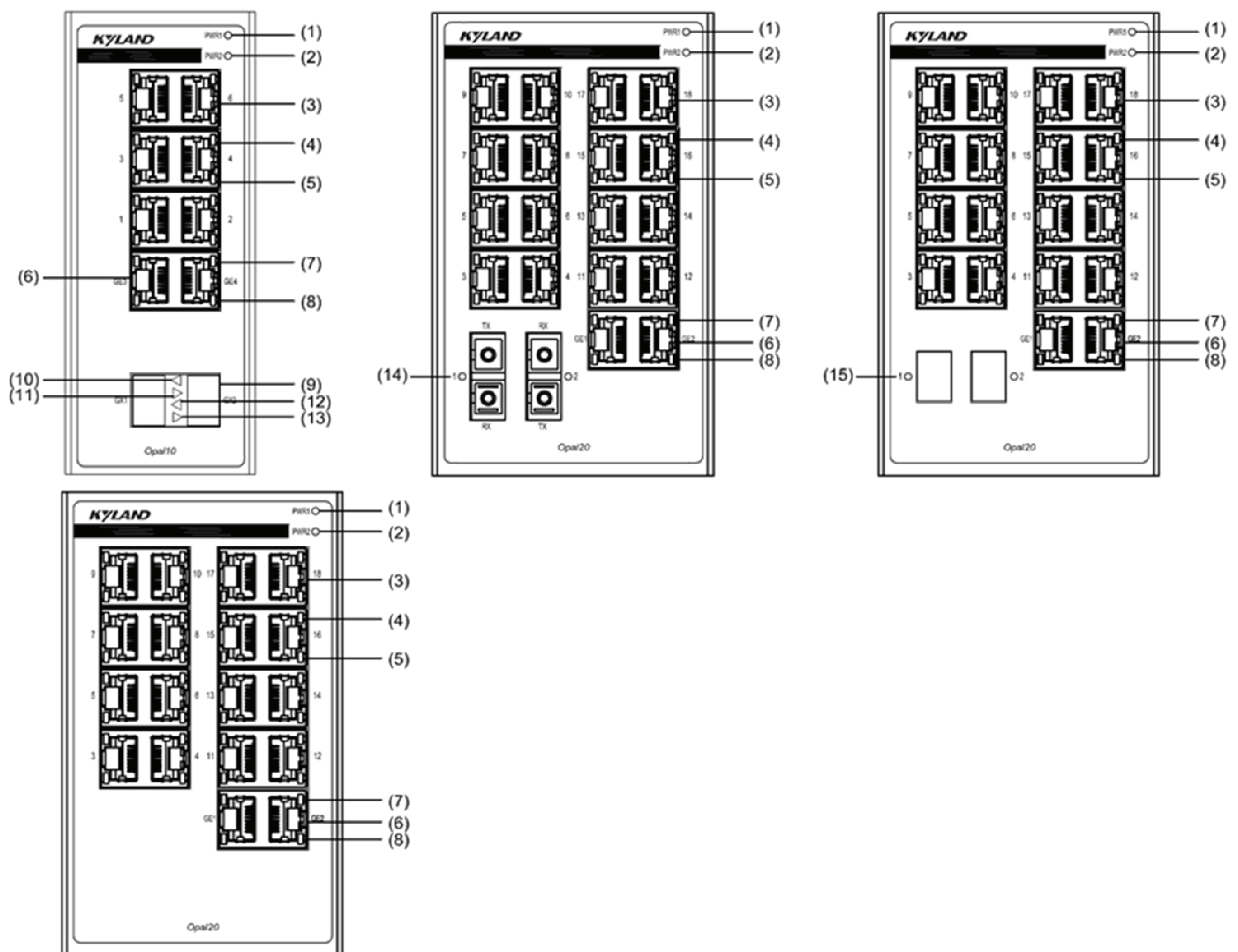

Figure 1 Front Panel

- (1) Power 1 LED
- (2) Power 2 LED
- (3) 10/100Base-T(X) Ethernet Port
- (4) 10/100Base-T(X) Ethernet Port connection status LED (green)
- (5) 10/100Base-T(X) Ethernet port speed LED (yellow)
- (6) 10/100/1000Base-T(X) Ethernet Port



- (7) 10/100/1000Base-T(X) Ethernet Port connection status LED (green)
- (8) 10/100/1000Base-T(X) Ethernet port speed LED (yellow)
- (9) 100/1000Base-X SFP slot
- (10) 100/1000Base-X SFP slot speed LED (yellow, indicating the speed of the left slot)
- (11) 100/1000Base-X SFP slot connection status LED (green, indicating the status of the left slot)
- (12) 100/1000Base-X SFP slot speed LED (yellow, indicating the speed of the right slot)
- (13) 100/1000Base-X SFP slot connection status LED (green, indicating the status of the right slot)
- (14) 100Base-FX Ethernet port and its connection status LED
- (15) 100Base-X SFP slot and its connection status LED

## 2.2 Top Panel

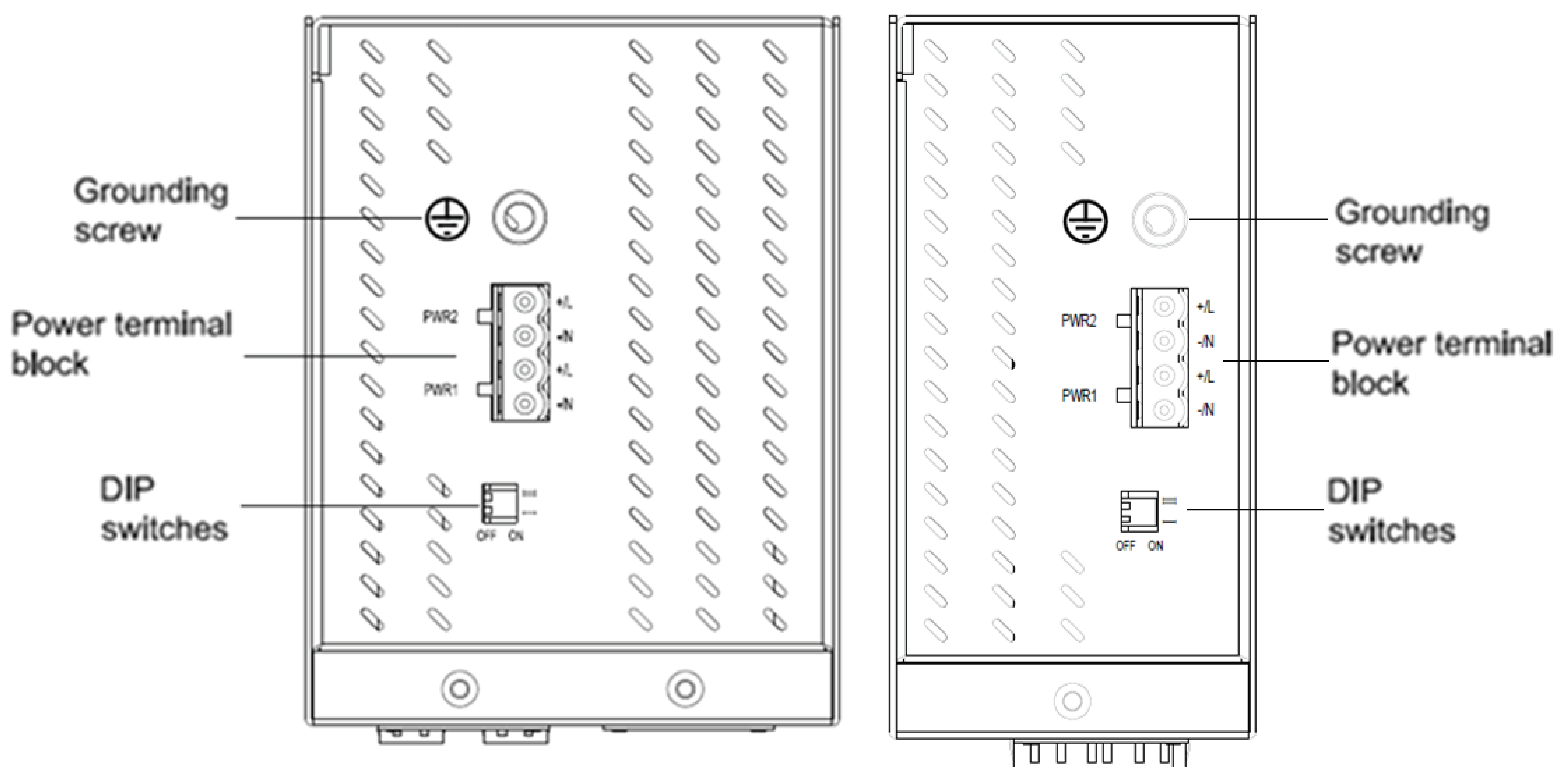

Figure 2 Top Panel

### 3 Mounting

#### 3.1 Dimension Drawing

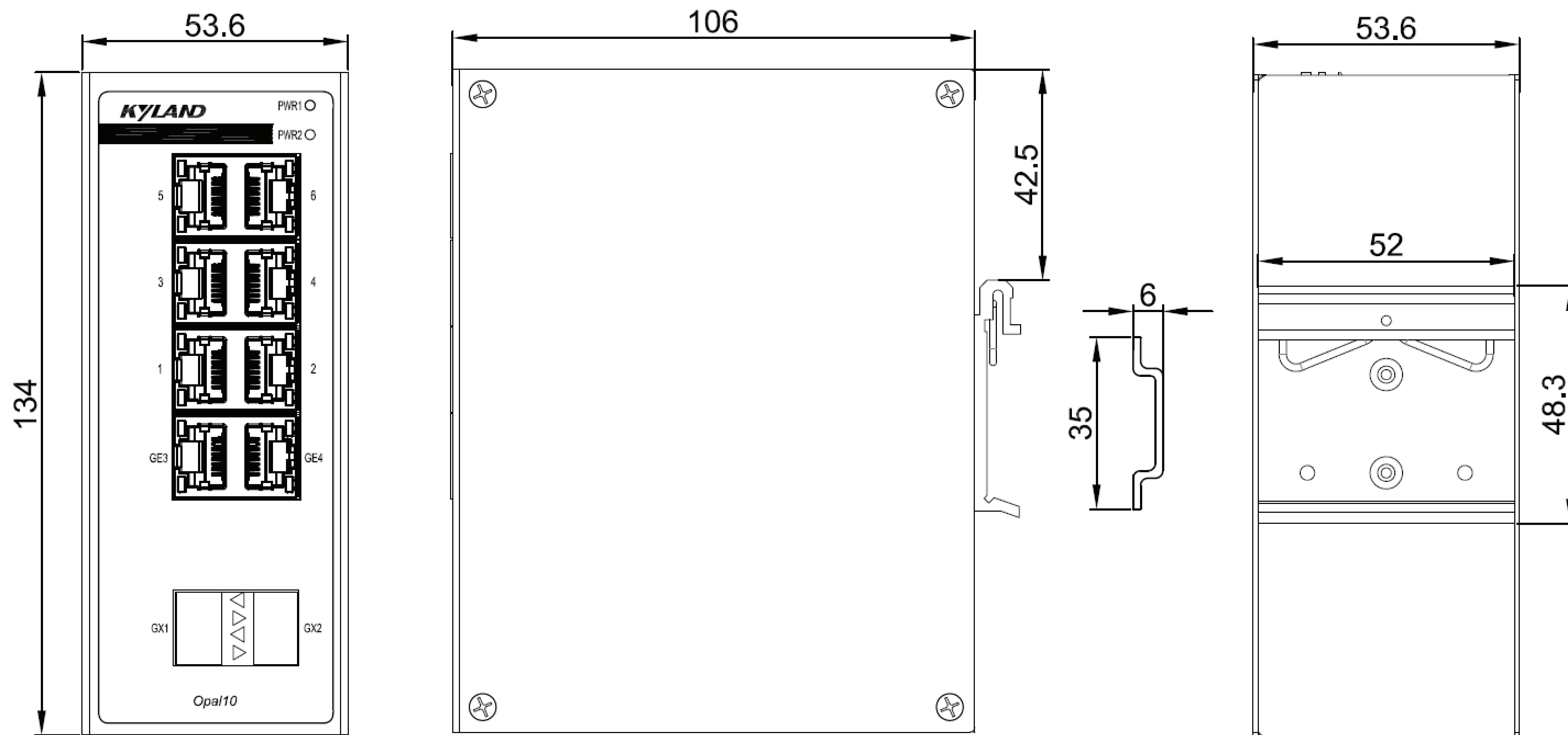

Figure 3 Opal10 Dimensions for DIN-Rail Mounting (unit: mm)

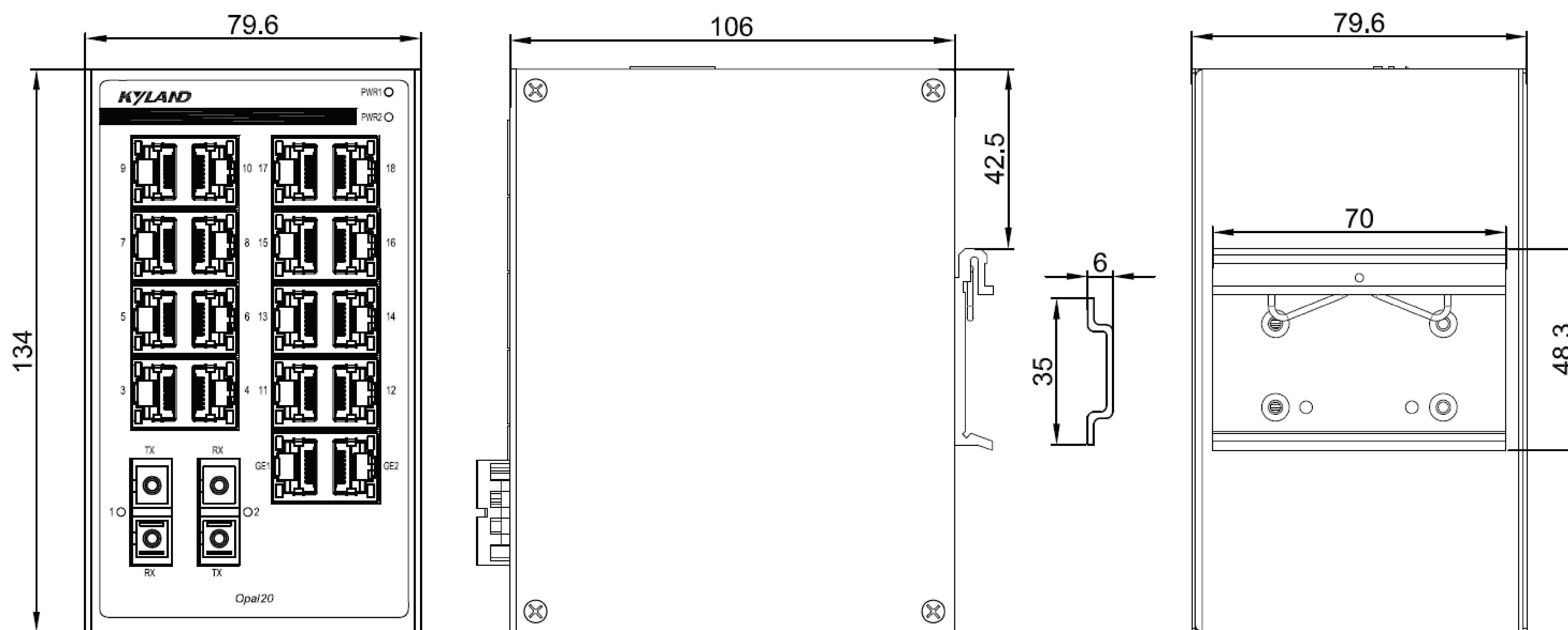

Figure 4 Opal20 Dimensions for DIN-Rail Mounting (unit: mm)



**Caution:**

- As part of the heat dissipation system, the switch housing becomes hot during operation. Please use caution when coming in contact and avoid covering the switch housing when the switch is running.
- The figures in this manual are only for reference.



## 3.2 Mounting Modes and Steps

The device supports DIN-rail mounting. Before installation, make sure that the following requirements are met.



**Note:**

- Devices are to be installed in an ATEX /IECEX Certified IP54 enclosure and accessible only by the use of a tool.
- Devices are for use in an area of not more than pollution degree 2 in accordance with IEC 60664-1.
- Customer shall insure device working in the right ambient temperature,  $-10 \leq T_{amb} \leq +60^{\circ}\text{C}$  for Opal10-E & Opal20-E series and  $-40 \leq T_{amb} \leq +75^{\circ}\text{C}$  for Opal10 & Opal20 series.
- No direct sunlight, distant from heat source and areas with strong electromagnetic interference.

### 3.2.1 DIN-Rail Mounting

Step 1: Select the mounting position for the device and guarantee adequate space and heat dissipation.

Step 2: Insert the connecting seat onto the top of the DIN rail, and push the bottom of the device inward and upward to ensure the DIN rail fits in the connecting seat. Make sure the device is firmly installed on the DIN rail, as shown in the following figure.

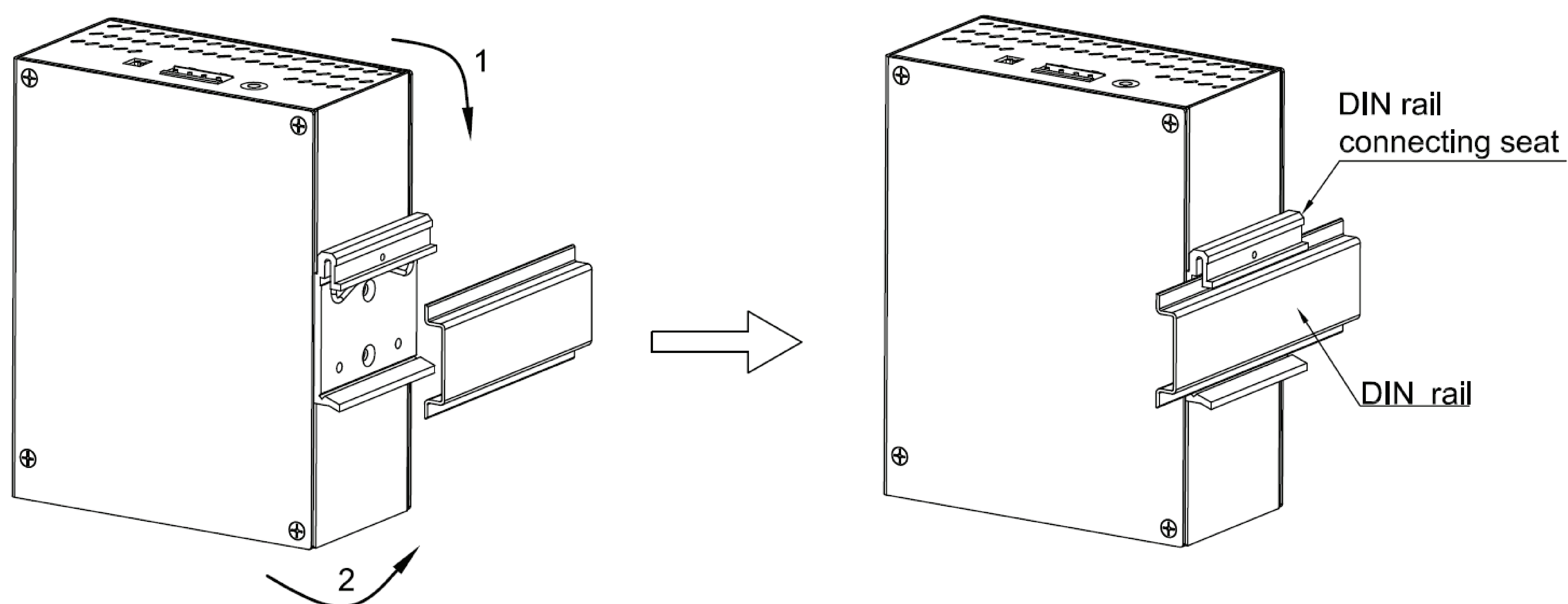

Figure 5 DIN-Rail Mounting

### 3.2.2 DIN-Rail Dismounting

Step 1: As shown in the following figure, press the device downward and move the device in direction 1 until the bottom of the device is detached from the DIN rail.

Step 2: Pull the device upward and move the device in direction 2 until the device is removed from the DIN rail completely.

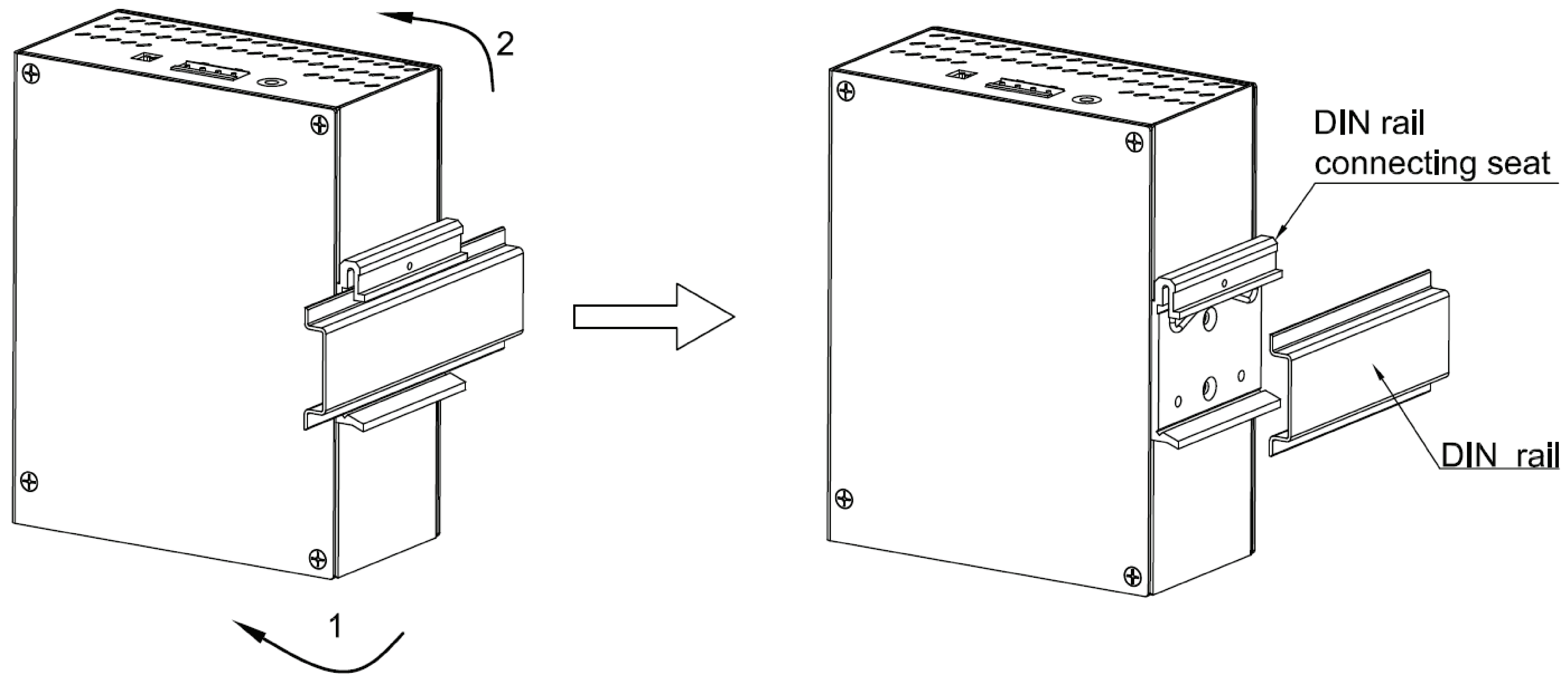

Figure 6 DIN Rail Dismounting



## 4 Connection

### 4.1 10/100Base-T(X) Ethernet Port

10/100Base-T(X) Ethernet port is equipped with RJ45 connector. The port is self-adaptive. It can automatically configure itself to work in 10M or 100M state, full or half duplex mode. The port can also adapt to MDI or MDI-X connection automatically. You can connect the port to a terminal or network device with a straight-through or cross-over cable.

- Pin Definition

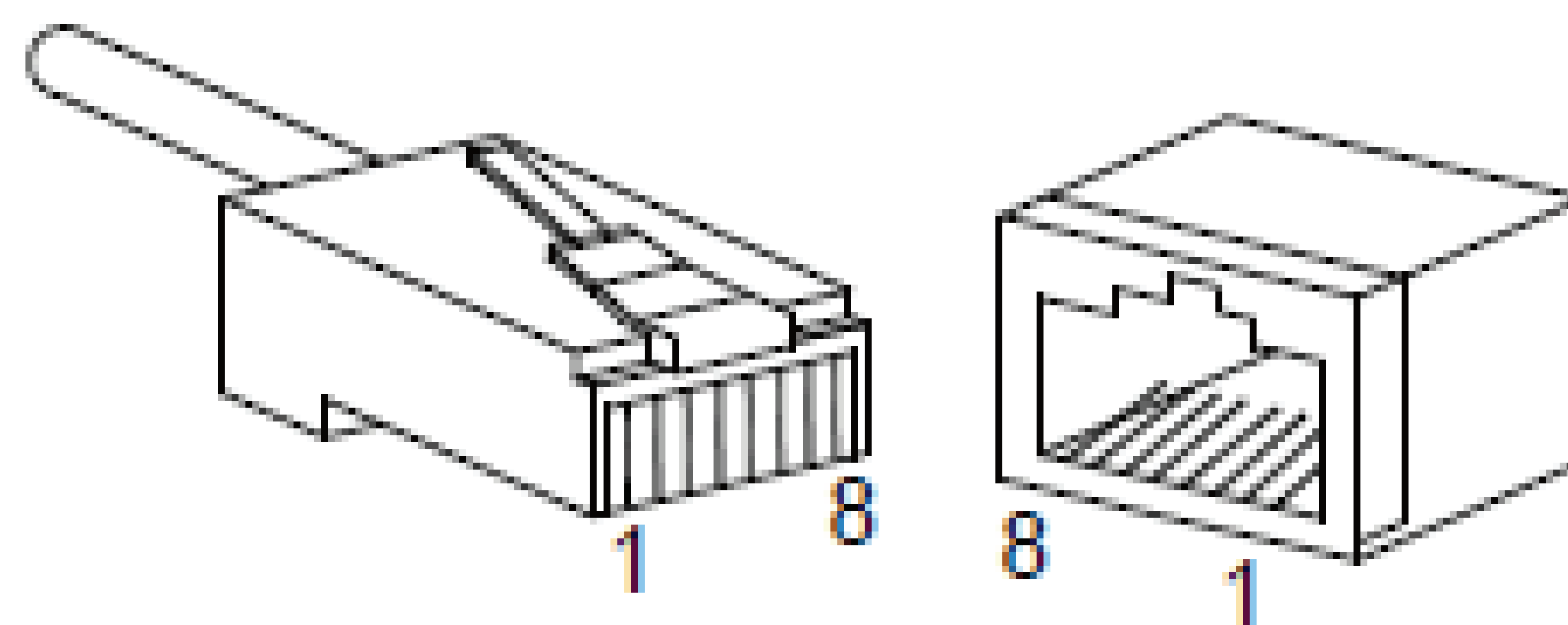

Figure 7 RJ45 Port

Table 3 Pin Definitions of 10/100Base-T(X) RJ45 Port

Pin	MDI-X Signal	MDI Signal
1	Receive Data+ (RD+)	Transmit Data+ (TD+)
2	Receive Data- (RD-)	Transmit Data- (TD-)
3	Transmit Data+ (TD+)	Receive Data+ (RD+)
6	Transmit Data- (TD-)	Receive Data- (RD-)
4, 5, 7, 8	Unused	Unused



**Note:**

"+" and "-" indicate level polarities.

- Wiring Sequence

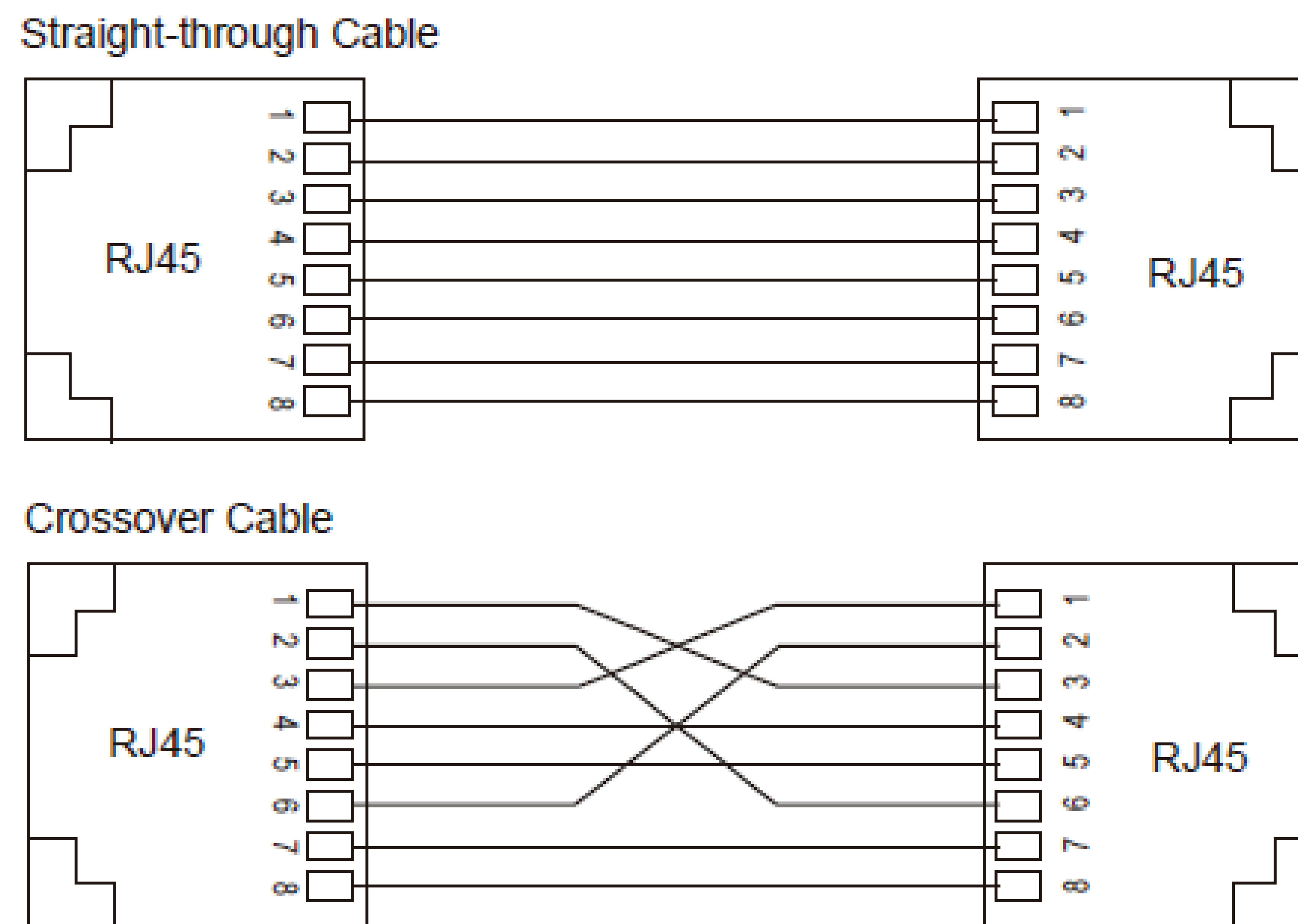

Figure 8 Connection Using Straight-through/Cross-over Cable



**Note:**

The color of the cable for RJ45 connector meets the 568B standard: 1-orange and white, 2-orange, 3-green and white, 4-blue, 5-blue and white, 6-green, 7-brown and white, and 8-brown.

## 4.2 100Base-FX Ethernet Port

100Base-FX Ethernet port is equipped with ST/SC connector, and each port consists of TX (transmit) port and RX (receive) port. To enable data transmission between Device A and Device B, connect the TX port of Device A to the RX port of Device B, and the RX port of Device A to the TX port of Device B. The following figure shows the wiring sequence of the 100Base-FX Ethernet port. (The following uses an SC port as an example. The wiring sequence of an ST port is the same with that of the SC port.)

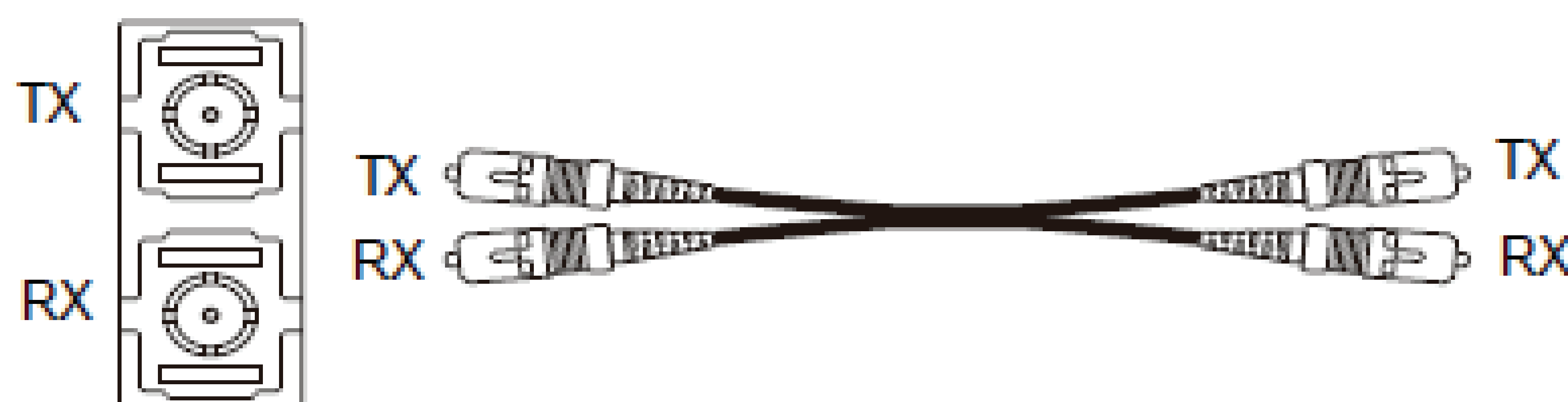

Figure 9 Connection of 100Base-FX Ethernet Port





**Caution:**

The device uses laser to transmit signals in fibers. The radiation has not been evaluated. The laser meets the requirements of level 1 laser products. Routine operation is not harmful to your eyes, but do not look directly at the fiber port when the device is powered on.

If the customer wants to purchase the SFP module separately, the SFP module must have a UL-certified class I module (Operating temperature support above 85 ° C).

### 4.3 100Base-X SFP Slot

100Base-X SFP slot: You can enable data transmission only after inserting an SFP optical module into the slot and connecting cable properly. The switch, which name contains “SMSFP” or “MMSFP”, is equipped with the SFP optical modules in the following table.

Table 4 SFP Optical Modules for 100Base-X SFP slot

<b>Model</b>	<b>Interface</b>	<b>MM /SM</b>	<b>Connector</b>	<b>Transmission Distance</b>	<b>Manufacturer</b>
HSFP-03-3312M-22F	100Base-FX port	MM	LC	2km	HI-OPTTEL
HSFP-03-3312S-22F	100Base-FX port	SM	LC	20km	HI-OPTTEL
OP3220D	100Base-X port	SM	LC	20km	OPWAY
OP3202D	100Base-X port	MM	LC	2km	OPWAY

The center Wavelength (CWL) of SFP module above is 1310nm, and the Operating temperature of SFP module above is not lower than 85 °C.

For how to connect the SFP optical module, please see 4.5 SFP Optical Module.

### 4.4 10/100/1000Base-T(X) Ethernet Port

10/100/1000Base-T(X) Ethernet port is equipped with RJ45 connector. The port is self-adaptive. It can automatically configure itself to work in 10M, 100M, or 1000M state, full or half duplex mode. The port can also adapt to MDI or MDI-X connection automatically. You can connect the port to a terminal or network device with a straight-through or cross-over cable.

● Pin Definition

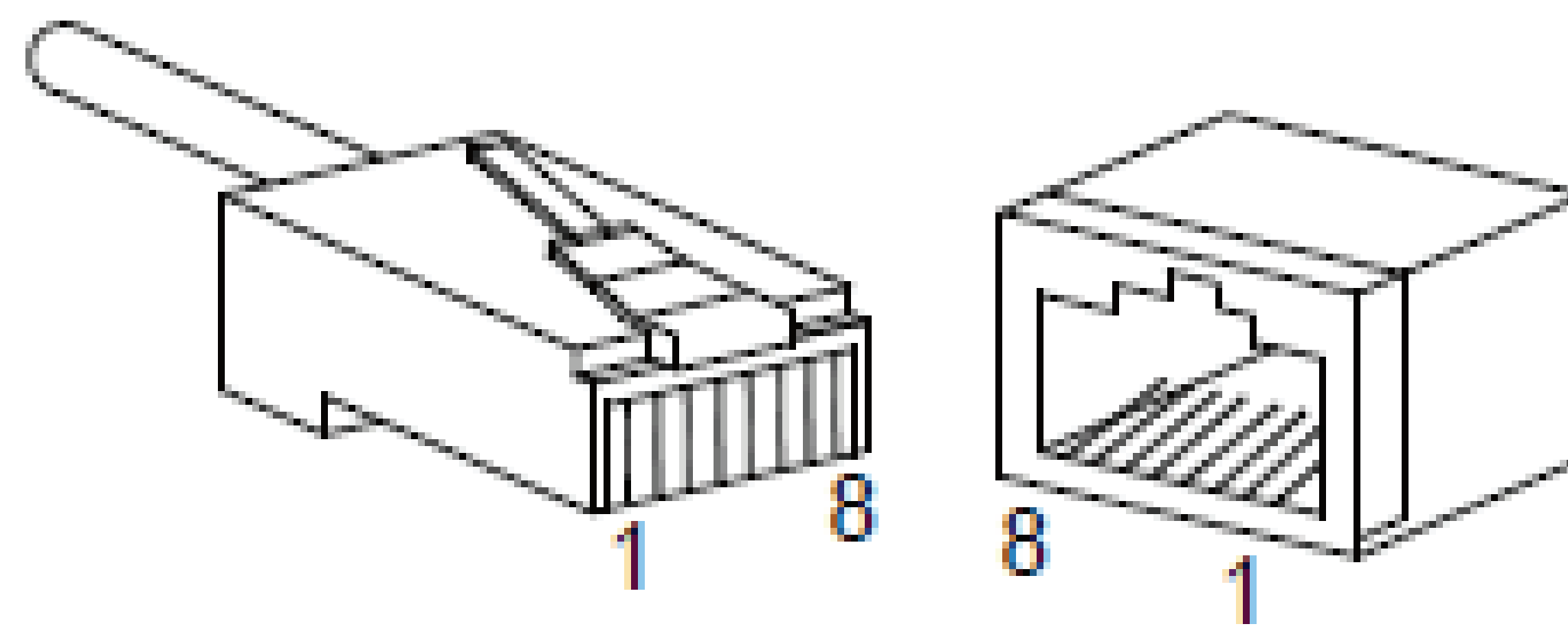

Figure 10 RJ45 Port

Table 5 Pin Definitions of 10/100Base-T(X) RJ45 Port

Pin	MDI-X	MDI
1	Transmit/Receive Data (TRD1+)	Transmit/Receive Data (TRD0+)
2	Transmit/Receive Data (TRD1-)	Transmit/Receive Data (TRD0-)
3	Transmit/Receive Data (TRD0+)	Transmit/Receive Data (TRD1+)
4	Transmit/Receive Data (TRD3+)	Transmit/Receive Data (TRD2+)
5	Transmit/Receive Data (TRD3-)	Transmit/Receive Data (TRD2-)
6	Transmit/Receive Data (TRD0-)	Transmit/Receive Data (TRD1-)
7	Transmit/Receive Data (TRD2+)	Transmit/Receive Data (TRD3+)
8	Transmit/Receive Data (TRD2-)	Transmit/Receive Data (TRD3-)



**Note:**

"+" and "-" indicate level polarities.

● Wiring Sequence

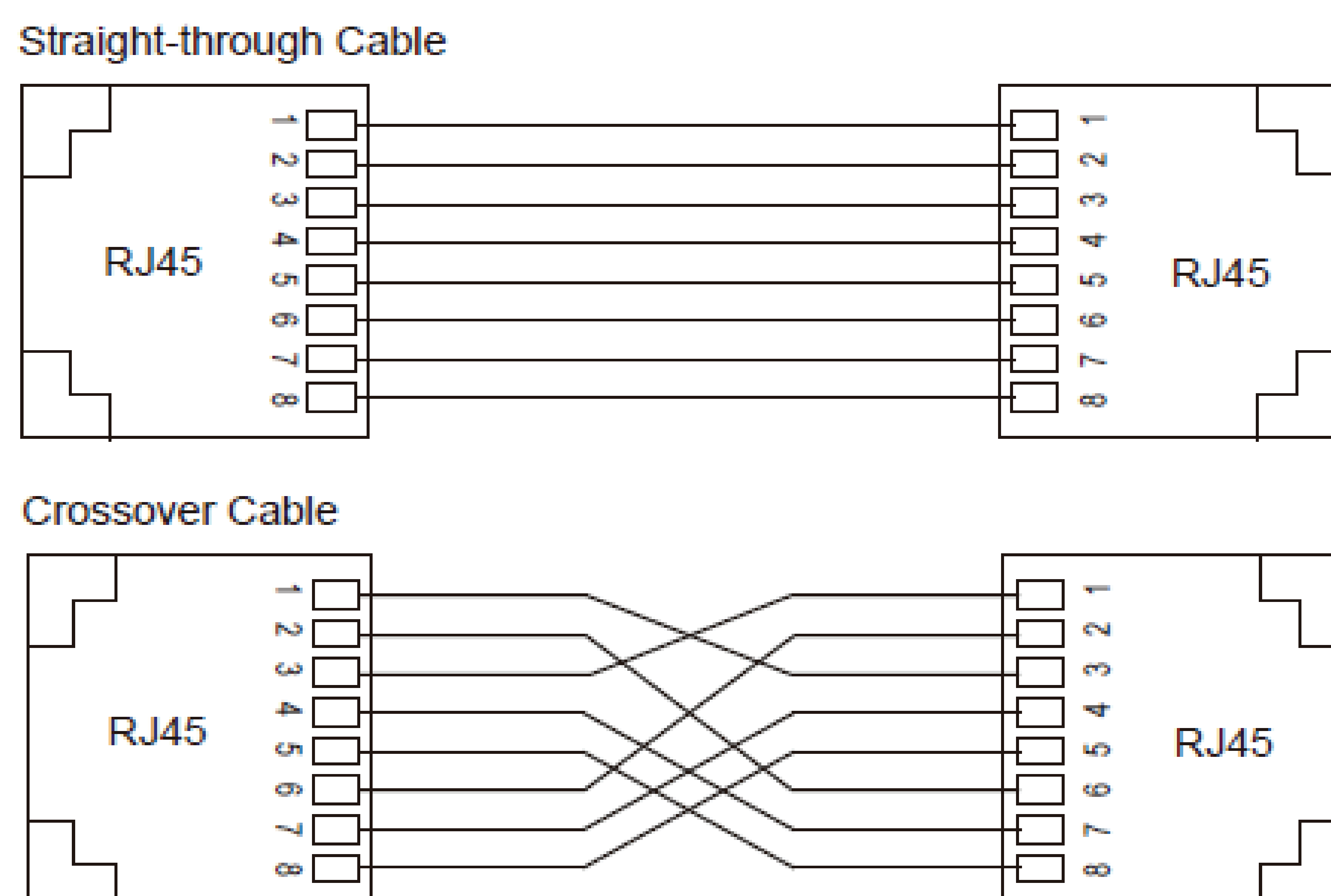

Figure 11 Connection Using Straight-through/Cross-over Cable





**Note:**

The color of the cable for RJ45 connector meets the 568B standard: 1-orange and white, 2-orange, 3-green and white, 4-blue, 5-blue and white, 6-green, 7-brown and white, and 8-brown.

### 4.5 100/1000Base-X SFP slot

100/1000Base-X SFP slot (gigabit SFP slot) requires an SFP optical module to enable data transmission.

- SFP Optical Module

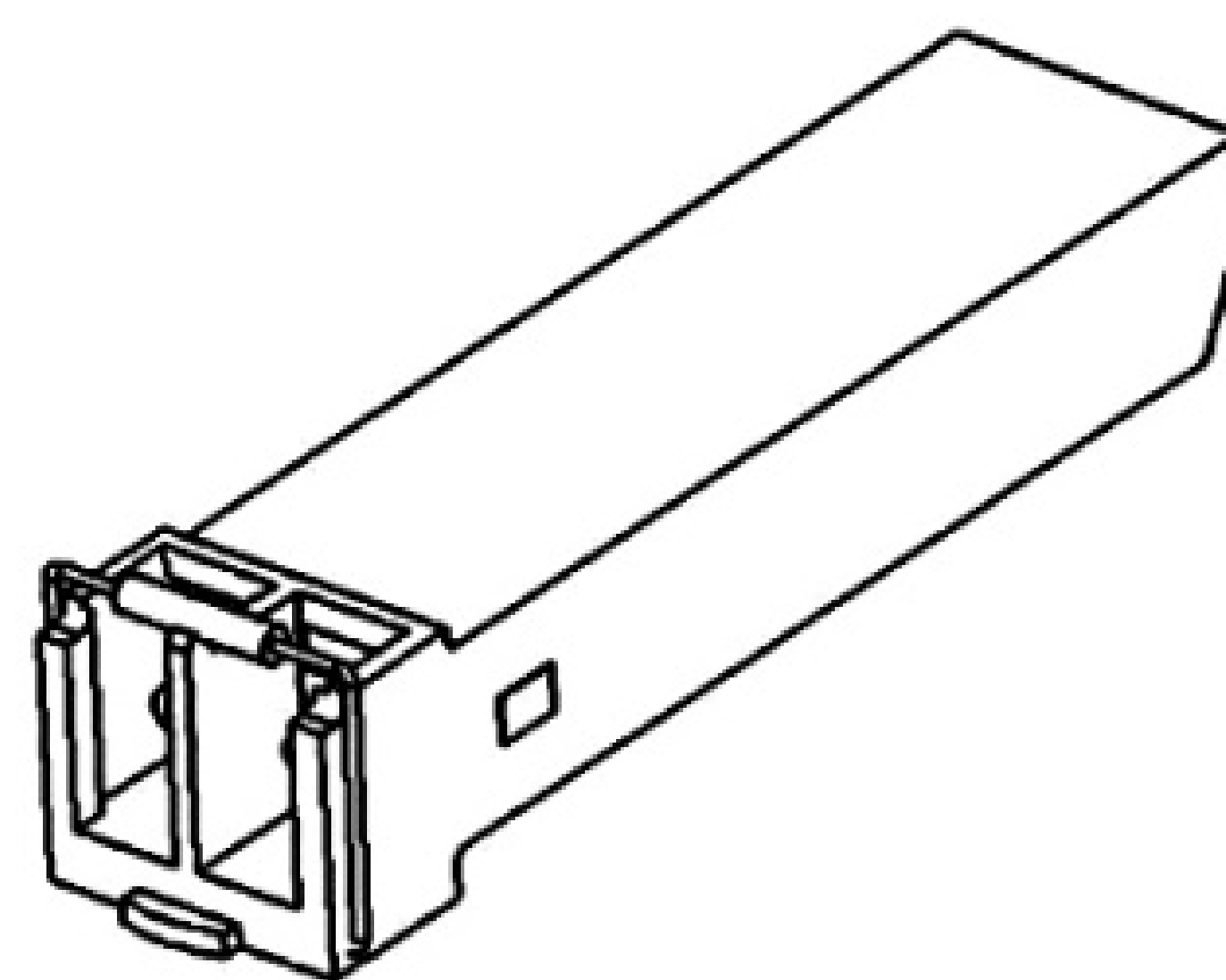

Figure 12 SFP Optical Module

An SFP optical module is equipped with LC connector, and each port consists of a TX (transmit) port and an RX (receive) port. To enable communication between Device A and Device B, connect the TX port of Device A to the RX port of Device B, and the RX port of Device A to the TX port of Device B, as shown in the following figure.

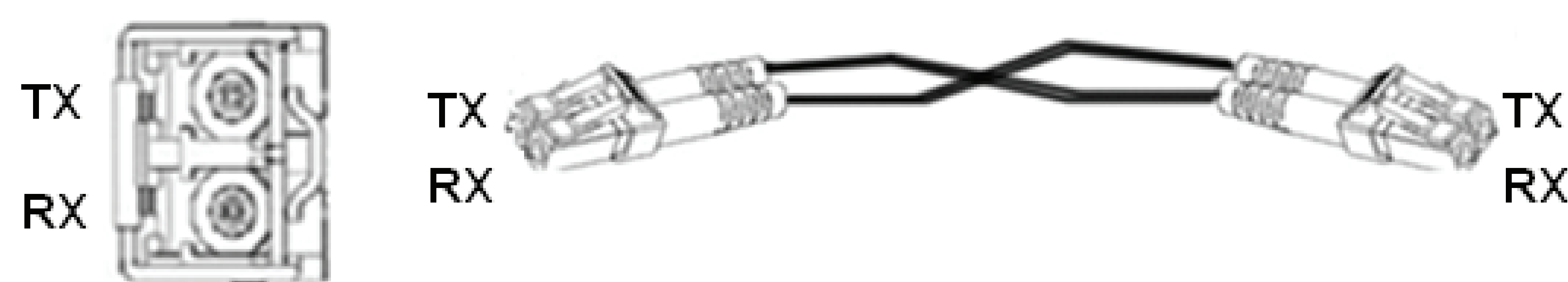

Figure 13 Fiber Connection of an SFP Optical Module

- How to Connect the SFP Optical Module

Insert the SFP optical module into the SFP slot in the switch, and then insert the fibers into the TX port and RX port of the SFP module.



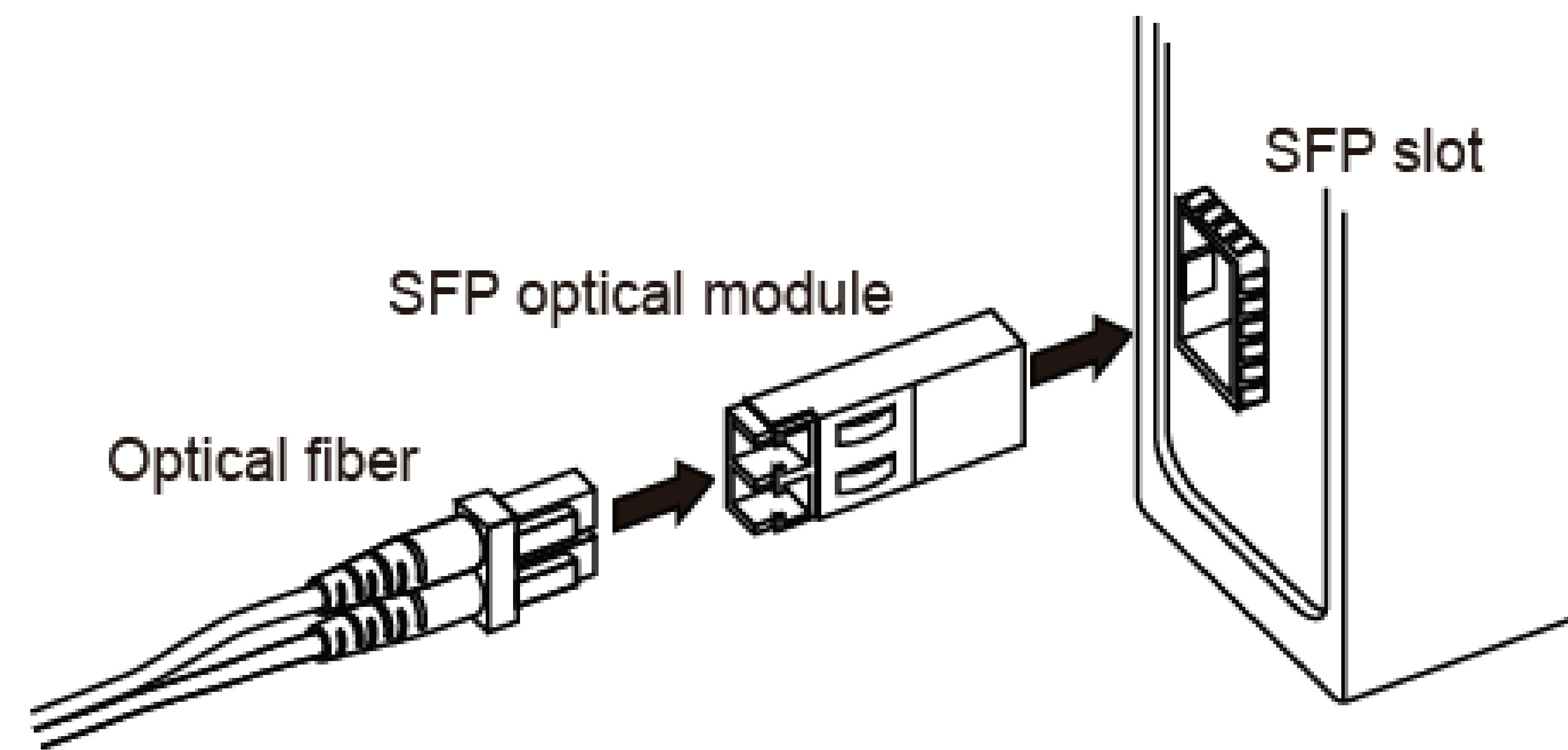

Figure 14 Connecting the SFP Optical Module

Identify the RX port and TX port of an SFP optical module:

1. Insert the two connectors in one end of two fibers into the SFP module, and those in the other end into the peer module.
2. View the corresponding connection status LED:  
If the LED is on, the connection is correct. If the LED is off, the link is not connected. This may be caused by incorrect connection of the TX and RX ports. In this case, swap the two connectors at one end of the fibers.



**Caution:**

- The device uses laser to transmit signals in fibers. The laser meets the requirements of level 1 laser products. Routine operation is not harmful to your eyes, but do not look directly at the fiber port when the device is powered on.
- If the defined transmission distance of an SFP module is longer than 60km, do not use a short fiber (<20km) for connection. If such a short fiber is used, the module will be burned.

## 4.6 Grounding

Grounding protects the device from lightning and interference. Therefore, you must ground the device properly. You need to ground the device before it is powered on and disconnect the grounding cable after the device is powered off.

There is a grounding screw (see Figure 2) on the top panel of the switch. The screw is for chassis grounding. After crimping one end of the grounding cable to a cold pressed terminal, secure the end of the grounding cable to the grounding screw and firmly connect the other end to ground.



**Note:**

Cross-sectional area of the chassis grounding cable  $>2.5\text{mm}^2$ ; Grounding resistance  $<0.1\Omega$ .



## 4.7 Power Terminal Block

There is a power terminal block on the top panel of the device. You need to connect the power wires to the terminal block to provide power for the device. The switch supports redundant power supply with 4-pin 5.08mm-spacing plug-in terminal block. When one power input is faulty, the switch can continue operating properly, thereby improving network reliability



**Note:**

- Use copper conductors only, temperature rating 85.5°C only.
- All field wiring intended for connection to the power terminal shall consist of copper conductors with the insulation locally removed. Additional intermediate connecting parts, other than ferrules, shall not be used.
- The exposed power cable wires connecting the plug-in terminal block should be 3-5mm approximately.

- 4-Pin 5.08mm-Spacing Plug-in Terminal Block

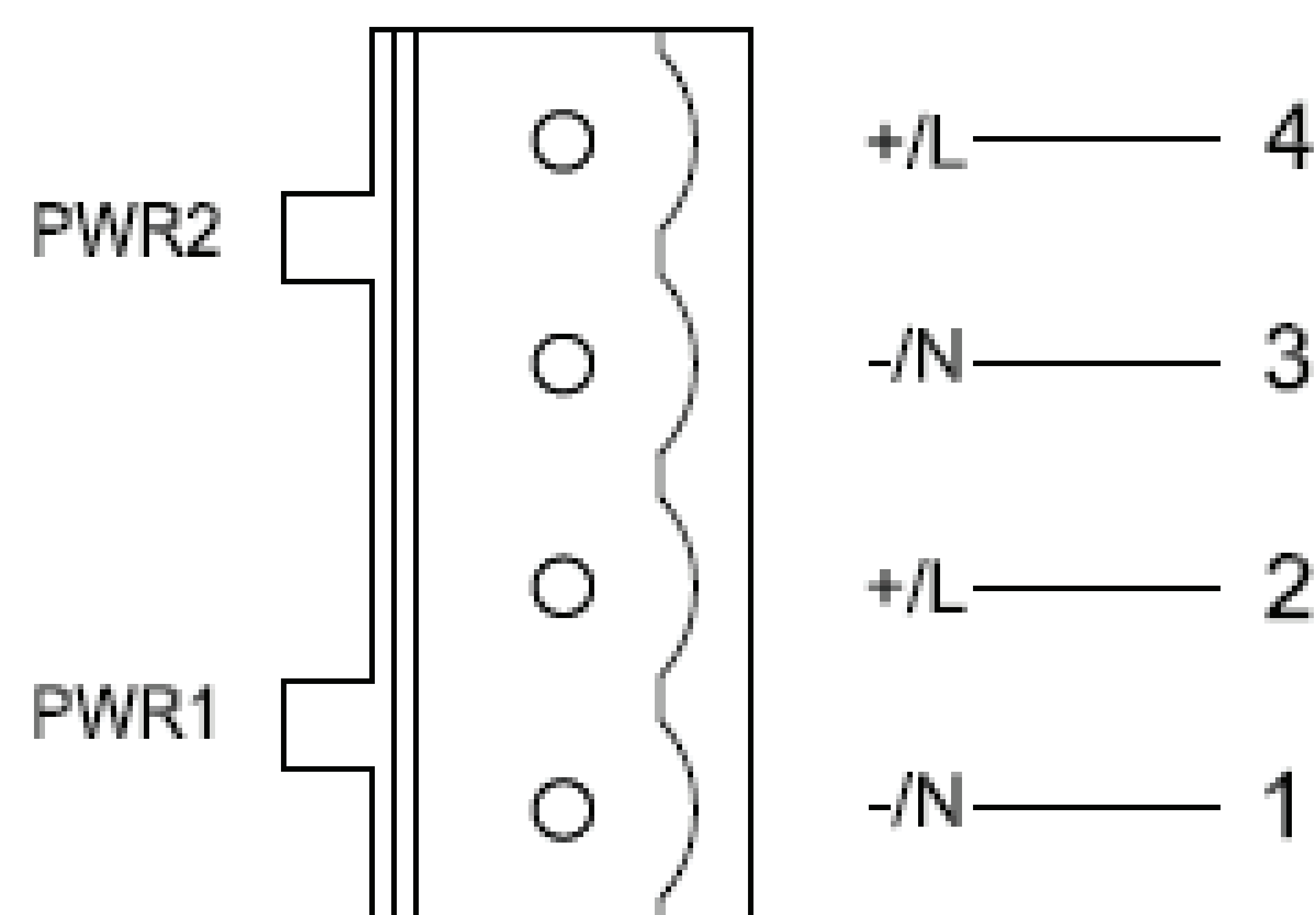

Figure 15 4-Pin 5.08mm-Spacing Plug-in Terminal Block (socket)

Table 6 Pin Definitions of 4-Pin 5.08mm-Spacing Plug-in Terminal Block

Pin Number	DC Wiring Definition	AC Wiring Definition
1	PWR1: -	PWR1: N
2	PWR1: +	PWR1: L
3	PWR2: -	PWR2: N
4	PWR2: +	PWR2: L

- **Wiring and Mounting**

Step 1: Ground the device properly according to section 4.6.

Step 2: Remove the power terminal block from the device.

Step 3: Insert the power wires into the power terminal block according to Table 6 and secure the wires.

Step 4: Insert the terminal block with the connected wires into the terminal block socket on the device.

Step 5: Connect one end of the power cable to an external power supply system (with the allowed power range). If the power LED on the front panel of the switch turns on, the power supply is connected properly.

Wiring and mounting should meet following specifications.

Table 7 Wiring and Mounting Specifications

Terminal Type	Required Torque	Wire Range (AWG)
Terminal Block Plug	4.5-5.0 lb-in	12-24



**Caution:**

- Provision shall be made to prevent the rated voltage from being exceeded by transient disturbances of more than 140% of the rated voltage.
- Power adapter provide by end customer shall be non-sparking.
- Before connecting the device to power supply, make sure that the power input meets the power requirement. If connected to an incorrect power input, the device may be damaged.
- To comply with UL restrictions, this equipment must be powered from a source compliant with SELV.



**Warning:**

- Do not touch any exposed conducting wire, terminal, or component with a voltage warning sign, because it may cause personal injury.
- Do not remove any part or plug in or out any connector when the device is powered on.



## 4.8 DIP Switches

There are two DIP switches on the top panel of the device, each switch has ON and OFF states, and the default state is OFF. The function of the DIP switches is shown in the following table.

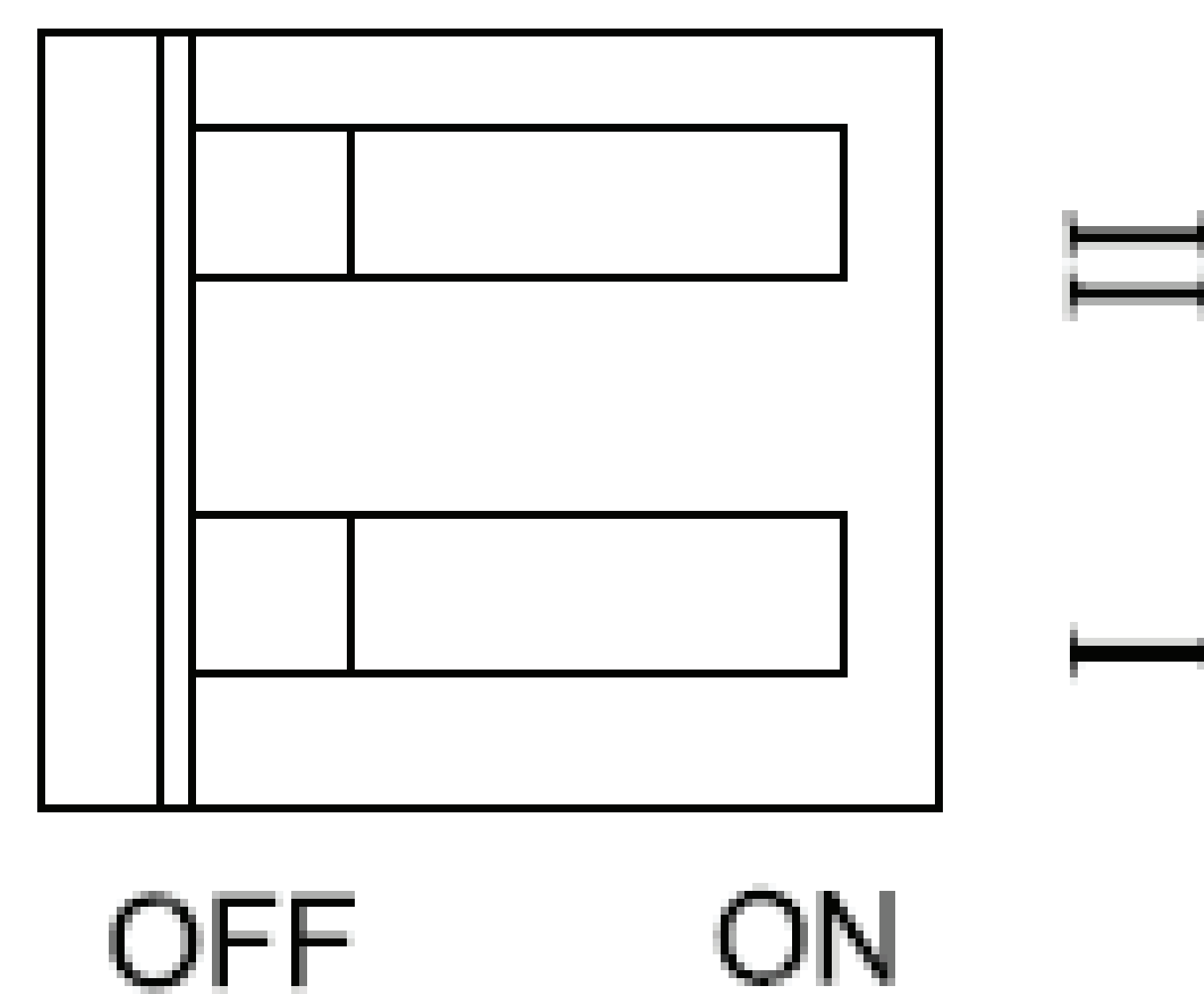

Figure 16 DIP Switches

Table 8 Description of the DIP Switches

DIP Switches		State	Description
I		ON	Enable broadcast storm protection
		OFF	Disable broadcast storm protection
II	Opal10	ON	The SFP slots are 100Base-X SFP slots
		OFF	The SFP slots are 1000Base-X SFP slots
	Opal20	Reserved	



**Note:**

The SFP slots should be inserted the corresponding SFP optical module according to the state of DIP switch II for Opal10.

## 5 LEDs

Table 9 LEDs

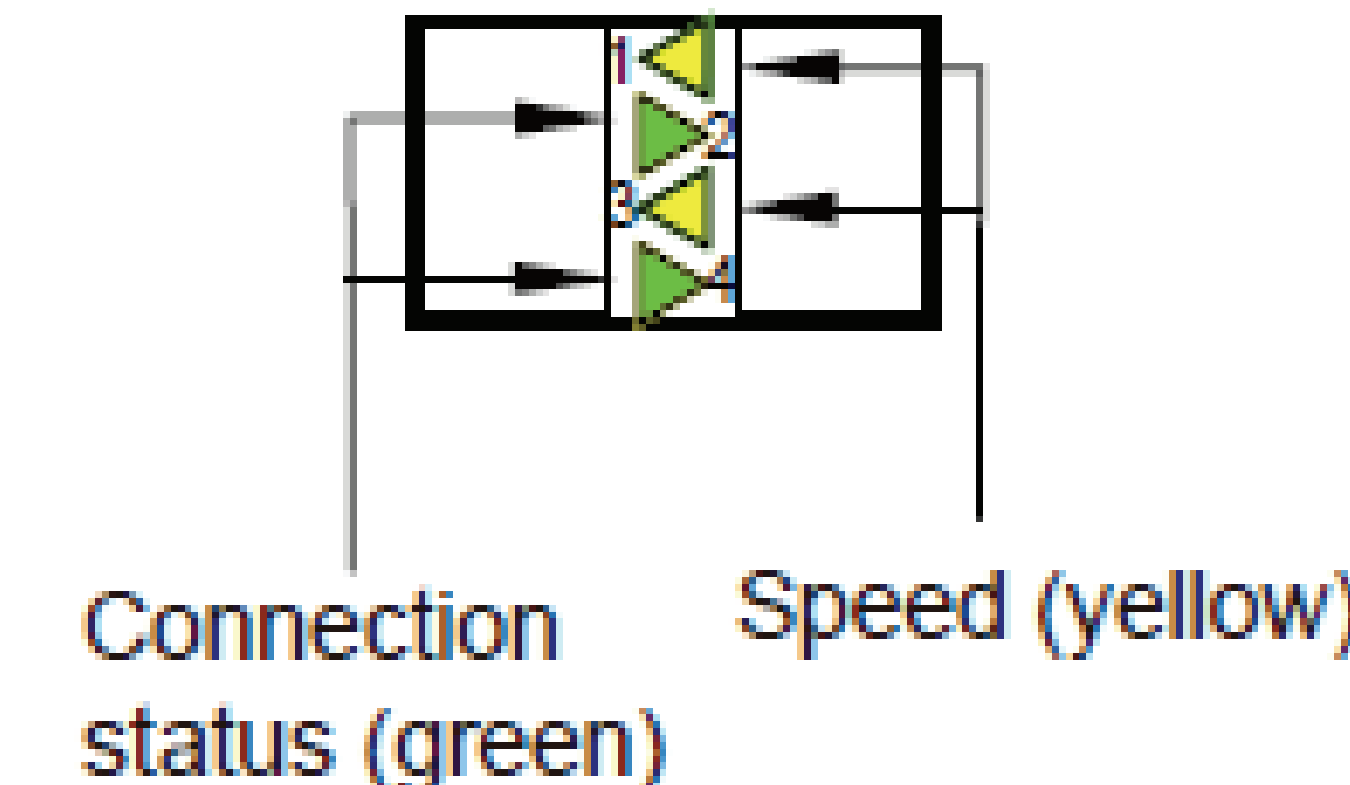
LED	State	Description
Power 1 LED	On	The power 1 is connected and operates properly.
	Off	The power 1 is not connected or operates abnormally.
Power 2 LED	On	The power 2 is connected and operates properly.
	Off	The power 2 is not connected or operates abnormally.
100Base-FX Ethernet port /100Base-X SFP slot connection status LED	On	Effective port connection
	Blinking	Ongoing network activities
	Off	No effective port connection
		
10/100Base-T(X) Ethernet port speed LED (yellow)	On	100M working state (100Base-TX)
	Off	10M working state or no connection
10/100/1000Base-T(X) Ethernet port speed LED (yellow)	On	1000M working state (1000Base-TX)
	Off	10/100M working state (10/100Base-T(X)) or no connection
10/100Base-T(X) Ethernet port and 10/100/1000Base-T(X) Ethernet port connection status LED (green)	On	Effective port connection
	Blinking	Ongoing network activities
	Off	No effective port connection
		
LED 1 and LED 2 indicate the status of the left SFP slot, while LED 3 and LED 4 indicate the status of the right SFP slot.		
100/1000Base-X SFP slot speed LED (yellow)	On	1000M working state (1000Base-X)
	Off	100M working state (100Base-FX) or no connection
100/1000Base-X SFP slot connection status LED (green)	On	Effective port connection
	Blinking	Ongoing network activities
	Off	No effective port connection



## 6 Basic Features and Specifications

<b>Power Supply</b>		
Power Identifier	Range	
LV	24VAC/DC(18-30VAC, 50/60Hz; 12-48VDC)	
Terminal Block	4-Pin 5.08mm-Spacing Plug-in Terminal Block	
<b>Rated Power Consumption</b>		
Rated Power Consumption	Opal10: 7.5W (MAX) Opal20: 8W (MAX)	
<b>Physical Characteristics</b>		
Housing	Metal, fanless	
Protection Class	IP30	
Installation	DIN-Rail Mounting	
Dimensions(W×H×D)	Opal10: 53.6mm×134mm×106mm Opal20: 79.6mm×134mm×106mm (excluding connectors, DIN rail)	
Weight:	Opal10: 0.5Kg Opal20: 0.7Kg	
<b>Environmental Limits</b>		
Ambient Temperature	-10°C ≤ Tamb ≤ 60°C	Opal10-E, Opal20-E series
	-40°C ≤ Tamb ≤ 75°C	Opal10, Opal20 series
Storage Temperature	-40°C ~ +85°C	
Ambient Relative Humidity	5% ~ 95% (no condensing)	
Pollution degree	2	
Altitude	2000m	
<b>MTBF</b>		
MTBF	Opal10: 2093638h Opal20: 1587575h	
<b>Warranty</b>		
Warranty	Five years	

if the equipment is used in a manner not specified by the manufacturer, the protection provided by the equipment may be impaired.

## 7 Certificates Used for Compliance

<b>Certificates Approvals</b>	
EMC	CE, FCC 47CFR Part2 and part15 Class A
Safety	UL508/UL61010,Class1Div2,ATEX/IECEX (UL508, ATEX and IECEX is not suitable on Opal20-2GE version)



## 8 Appendix



1. UL control number: 4SH7, 3MSY.
2. The product identity: IND. CONT. EQ. FOR HAZ. LOC. Class I, Division 2, Groups A, B, C and D Hazardous Locations.
3. Max Ambient temperature: 75°C for Opal10/20 series and 60°C for Opal10/20-E series.

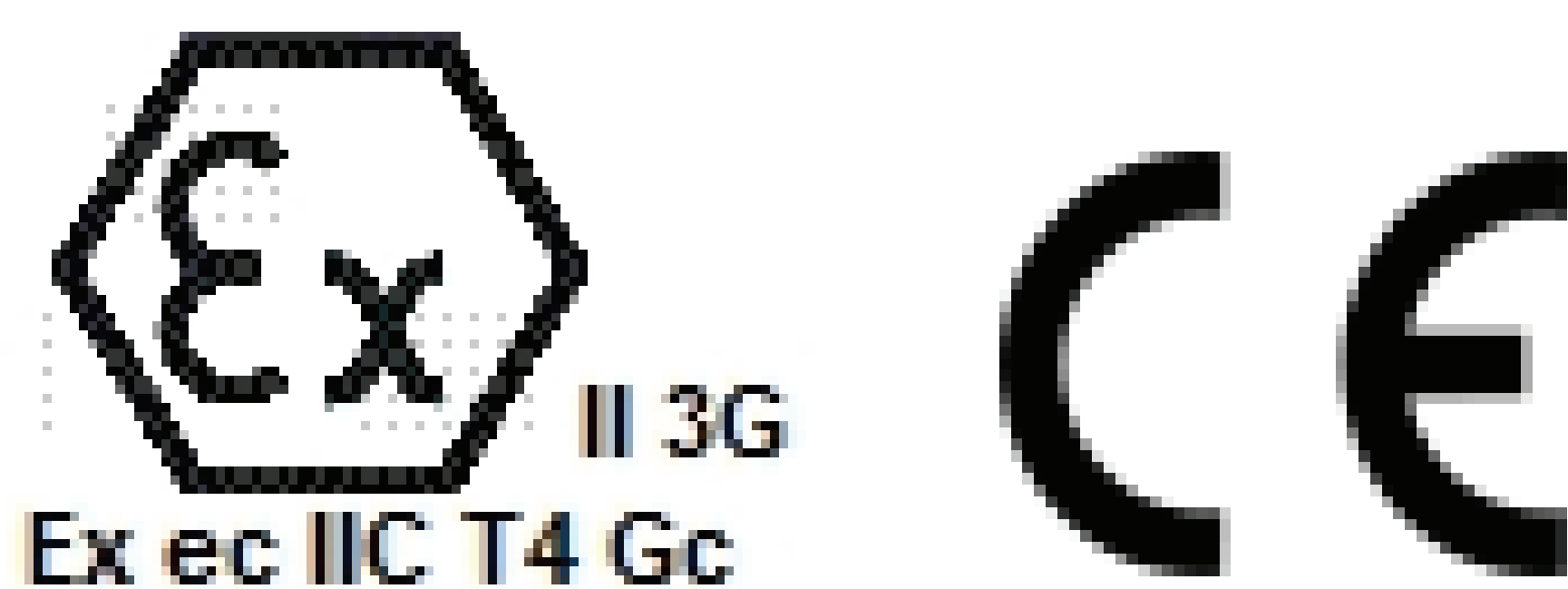

1. ATEX Certificate No: DEMKO 17 ATEX 1822X.
2. IECEx Certificate No: IECEx UL 17.0002X.
3. Protective method: Ex ec IIC T4 Gc.
4. Ambient rating:  $-40^{\circ}\text{C} \leq T_{\text{amb}} \leq +75^{\circ}\text{C}$  for Opal10/20 series and  $-10^{\circ}\text{C} \leq T_{\text{amb}} \leq +60^{\circ}\text{C}$  for Opal10/20-E series.
5. Standard covered:
  - EN IEC 60079-0:2018/IEC 60079-0:Ed.7.
  - EN 60079-7:2015/IEC 60079-7: Ed.5.1.
6. Condition of safe use:
  - The equipment shall only be used in an area of not more than pollution degree 2, as defined in EN/IEC 60664-1.
  - The equipment shall be installed in an enclosure that provides a degree of protection not less than IP 54 in accordance with EN IEC/IEC 60079-0 and enclosure only accessible with tool removable cover.
  - Transient protection shall be provided that is set at a level not exceeding 140 % of the peak rated voltage value at the supply terminals to the equipment.